



Tech-Talks BREGENZ: Dietmar Zembrot
Technologies for High Quality LED Lighting
Smart Lighting & Human Centric Lighting
Advanced Thermal Management Technologies

Lighting that **moves** products— and customers



In the world of retail, appearances are everything. Now with LUXEON CoB arrays featuring CrispWhite Technology, there's a better way to ensure merchandise is seen in its best possible light. This revolutionary LED is perfect for lighting applications where compromise is not an option—creating richer whites, more vibrant reds and colors that pop like never before.

When it comes to retail lighting that delivers unmatched intensity—and stops shoppers in their tracks—it's time to expect more. For additional information, contact your Philips Lumileds sales representative or visit us at www.philipslumileds.com/CrispWhite today.

PHILIPS
LUMILEDS



Lighting System Design

Innovations are mainly driven by technological developments and application demands. Lighting system design based on LED and OLED technologies is challenging. Preferred solutions have to incorporate the latest technologies, smart systems, new standards, advanced functionalities and new user behaviors. Therefore, successful solutions require a holistic design and engineering approach to create new designs and to transform innovations to the next levels.

This is the objective of the upcoming 4th International LED professional Symposium +Expo (Sept. 30 – Oct. 2 in Bregenz, Austria), which covers LED and OLED lighting system technologies for luminaires, lamps, modules and components. It focuses on novel system approaches, new components, equipment and up-to-date design methodologies. The LED professional Symposium +Expo is designed to outline background information and the latest trends, while suggesting innovative solutions to engineering problems.

The LpS 2014, organized by the LED professional team, encompasses the latest information about state-of-the-art technology and developments within the entire range of topics that Solid State Lighting encompasses. It covers lectures from the following sessions: Trends and Visions for Future LED Lighting Systems, Reliability and Lifetime of LED Lighting Systems, Trends in LED Light Sources, Trends in Materials and Manufacturing, Design with LEDs and OLEDs, Engineering of LED Optics, Engineering of LED Electronics and Smart Lighting and Product & Application Approaches.

Inside this issue of LpR, Sergei Ikoenko, a professor at MIT and one of the leading experts in the field of systematic innovations, talks about applying suitable methodologies during the design process, which also drives innovations. In his commentary he states that technical systems evolve according to well-defined trends and laws that are valid independently of the field of application.

We also have to understand the application, the market and the industry rules for appropriate designs. To find out what the cornerstones are for new developments and how the lighting industry copes with SSL, we invited Mr. Dietmar Zembrot, President of LightingEurope, for a Tech-Talk in BREGENZ.

Furthermore, this LpR issue covers “Technologies for High Quality LED Lighting”, “Smart Lighting”, “Human Centric Lighting” and “Advanced Thermal Management Technologies”.

Have a great read.

Yours Sincerely,

Siegfried Luger
CEO, Luger Research e.U.
Publisher, LED professional
Event Director, LpS 2014

Content

■	EDITORIAL	p 3	COMMENTARY	p 6
	IMPRINT	p 86	NEWS - PRODUCTS	p 8
			NEWS - RESEARCH	p 25
			NEWS - EVENTS	p 26

■	TECH-TALKS BREGENZ			
	Dietmar Zembrot, LightingEurope, President / TRILUX, CTO	p 30		
	by Dr. Amrita Prasad, LED professional			

■	TECHNOLOGY			
	High Color-Rendering, Full-Visible-Spectrum LEDs	p 38		
	by David Aurelien & Mike Krames, Soraa			

■	OPTICS			
	Light Guide Technology for Obtaining a Different Bi-Directional Direct / Indirect Light Emission Pattern	p 46		
	by Brett Shriver, Global Lighting Technologies			

■	THERMAL MANAGEMENT			
	Improving the Lifetime of Components Using Heat Conducting Plastics	p 52		
	by Thies Wrobel & Klaus Gebhardt, Albis Plastics			
	Advanced Passive Thermal Management Solutions for High Power LEDs	p 58		
	by Dr. R. Bonner & P. Ritt, Advanced Cooling Technologies (ACT)			

■	ELECTRONICS			
	Aspects of Intelligent Lighting	p 62		
	by Thomas Hauer, RECOM Engineering GmbH & Co KG			

■	APPLICATION			
	Lighting & Building Automation Technologies	p 70		
	by Greg Galluccio, Leviton Manufacturing			
	The Status of Human Centric Lighting (HCL)	p 76		
	by Dr. Stefan Tasch, Lumitech & Guido Nattkemper, BAG electronics			
	Tuneable Solid-State Lighting to Improve Light Quality	p 82		
	by Uwe Thomas, LED Engin			

Advertising Index

Philips Lumileds	p 2
Cree	p 5
BICOM	p 7
LedLink	p 9
Auer Lighting	p 10
Toshiba	p 11
Arrow Europe	p 11
Epistar	p 12
Lextar	p 13
Dangoo Electronics	p 13
Holy Stone International	p 14
CeramTec	p 15
Fraen	p 15
Tridonic	p 15
Orb Optronix	p 16
Fischer Elektronik	p 17
GL Optic	p 19
Vossloh-Schwabe	p 19
Signcomplex	p 21
Mouser Electronics	p 23
Honglitronic	p 24
Willighting	p 24
Ledfriend	p 24
Global Lighting Technologies	p 25
Cree	p 26
Instrument Systems	p 27
Underwriters Laboratories	p 29
Escatec	p 33
EKL	p 35
LpS 2014	p 37
Barthelme	p 41
Acal BFI	p 44
Osram	p 45
Refond	p 47
LED China	p 50
Edison	p 51
Fuhua	p 51
Fuhua	p 56
Electrolube	p 57
Shat-r-Shield	p 57
Honglitronic	p 61
Cree	p 65
Underwriters Laboratories	p 67
Cree	p 68
Microchip Technology	p 68
RECOM	p 69
Bender-Wirth	p 72
electronica	p 75
Fratelli Poli	p 77
KOSIGN	p 79
China Int. Optoelectronic Expo	p 79
Epistar	p 80
Instrument Systems	p 80
IMOS Gubela	p 81
Inpotron	p 81
Everfine	p 84
Illuminotronica	p 85
LED professional Review	p 87
WAGO	p 88



CREE® LIGHTING-CLASS LEDs AND LED MODULES

VARIETY IS THE SPICE OF LIGHT.

Every luminaire design has its own ingredients. That's why Cree® XLamp® LEDs and LED modules are optimized for specific applications. We pack more performance into our devices to serve up smaller, brighter, more efficient luminaires using fewer LEDs. Add a dash of our superior applications support, comprehensive luminaire testing services and our driver compatibility program, and you'll get a recipe for success.

Optimize your designs with Cree LED components.

Visit cree.com/optimize or call 866-924-3645



OUR PORTFOLIO HAS
MORE THAN 50 LED DEVICES.

CREE JUST BROKE THE
300 LUMENS/PER WATT BARRIER.

WHEN IT COMES TO INNOVATION,
NO ONE ELSE IS EVEN CLOSE.



DISCRETES

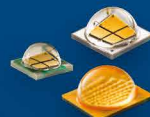

INTEGRATED ARRAYS



ARRAYS



MODULES



Sergei Ikoenko

Dr. Sergei Ikoenko is a leading consultant and project facilitator in innovation technology of design. He has conducted more than 900 courses on innovation topics for Fortune 500 companies worldwide. Dr. Ikoenko was the primary instructor to deliver corporate innovation programs at Procter & Gamble, Mitsubishi Research Institute, Samsung, Intel, Siemens, Hyundai Motor Group, etc.

Dr. Ikoenko is a Director of Innovation Leadership at GEN3Partners, a consulting firm in Boston. He holds doctorate degrees in Industrial Engineering, and in Environmental Engineering and Sciences as well as a Master degree in Patent Law. He has effectively utilized his expertise to receive 93 patents and numerous international engineering awards in various engineering fields.

LEARNINGS FROM SYSTEMATIC INNOVATION

Systematic Innovation is a scientific approach to innovation execution that uses analytical tools to identify root causes of an innovation challenge and then finds functionally related practical solutions that can be adapted quickly, effectively, and with less risk.

At the core of Systematic Innovation is a pragmatic and structured approach the key learnings of which are:

Understand Main Parameters of Value

Innovation is defined as a significant improvement in at least one Main Parameter of Value (MPV) – those factors that drive customer-purchasing decisions. Modern systematic innovation is uniquely adept at uncovering MPV's and translating them to underlying technical parameters that become the focus of innovation efforts. Maintaining this alignment with MPV's helps to ensure that technical innovation programs will yield economic value.

Consider Technology Evolution

It is known that products and technologies evolve according to evolutionary trends that are objective and predictable. Markets and technologies are dynamic; therefore, innovation programs cannot be static. Understanding where a technology is on its S-curve is critical to determining the type of innovation that will yield the best results. Moreover, anticipating how technologies will evolve helps to guide innovation directions that are forward looking.

Focus on Functions

At the foundation of systematic innovation is a functional approach. By modeling a product or process in functional terms and then developing a superior functional architecture, this unique functional lens reveals powerful insights critical to delivering innovation solutions. The functional approach to problem definition also provides a roadmap for effectively tapping into knowledge domains that may lie far beyond a client's area of expertise.

Address Key Problems

One of the cornerstones of systematic innovation is determining the right problem to be solved, which often may not be the initially stated problem.

Adapt Existing Solutions, Don't Always Invent

Systematic innovation uses functional approach to guide Function-Oriented Search, a structured means to identify technologies in potentially distant industries or areas of science and engineering that have functionally similar challenges. With this approach, it is possible to change the innovation challenge from one of invention to one of adaptation.

Such an approach of Systematic innovation

- Ensures that any innovation opportunity or challenge is rigorously analyzed so the right problems are attacked from the very start
- Eliminates unproductive and lower value efforts, captures and adapts proven solutions from other industries/domains
- Results in securing critical IP, reducing risk and dramatically improving time to market ■

S.I.



LED Tube Cover

BICOM

Professional LED Lenses & Reflectors Manufacturer

- Develop over 100 new products monthly
- Cooperate closely with Osram, Philips, Cree, Nichia etc.
- Have rich industry experience in optics design and manufacture
- Finish a new optical design within 3 days& trial-mould samples in 5 days
- Provide high efficiency LED Lenses, Reflectors, Tube& Bulb Covers

Single Lens



Reflector



LED Bulb Cover

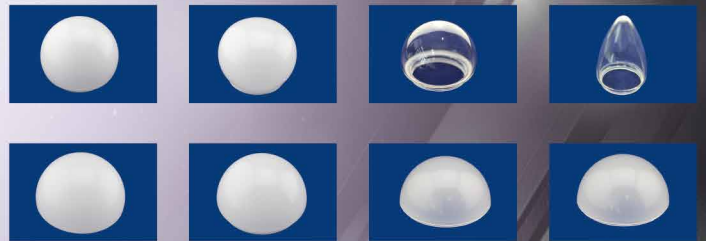

Streetlight Lens

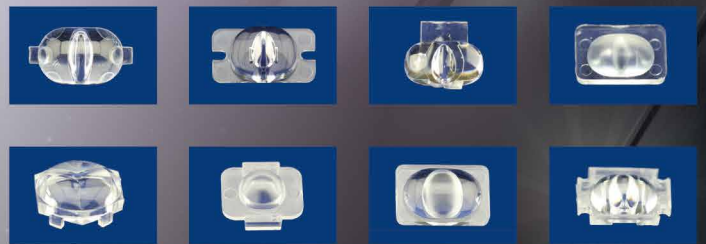

SHENZHEN, CHINA

TEL: +86-755-29199996

FAX: +86-755-82033711

HONGKONG

TEL: +852-39216016

FAX: +852-27837978

SHANGHAI

TEL: +86-21-33634169

FAX: +86-21-33634512



ADD: B4 BUILDING, XINJIANXING INDUSTRIAL PARK, FENGXIN ROAD, GUANGMING DISTRICT, SHENZHEN

Email: sales@bicomoptics.com

www.bicomoptics.com

SemiLEDs Releases Complete 80mil EV LED Chip Family

SemiLEDs Corporation, a global provider of vertical LED technology solutions, today announced sampling and volume availability of a complete line of 80x80 mil rugged metal LED chips, including white, blue, and UV variations. The EV-80mil family allows packagers and integrators a wider variety of high-efficiency/high-output choices to address the growing number of applications in both the commercial lighting and industrial spaces. With the new family, a single 80x80 mil device will typically replace four 40x40 mil LED chips, which simplifies packaging and optical designs, while minimizing color fringing and shadow effects common to multi-chip implementations. SemiLEDs EV family, which combines vertical LED architectures with rugged copper-alloy substrates, has proven to be especially well-suited for handling the increased thermal and electrical demands of large-chip implementations.

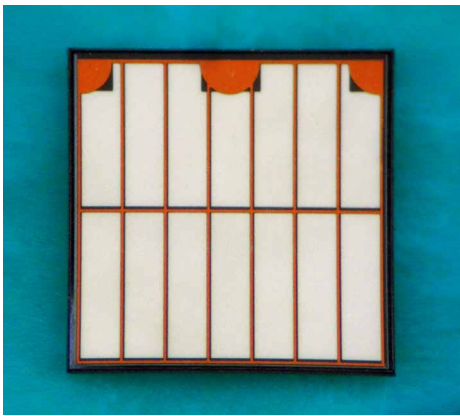

Example of SemiLEDs new EV-80mil series of LED chips

Mark Tuttle, General Manager for SemiLEDs Optoelectronics Co., Ltd., commented, "Applications in commercial and residential lighting, along with UV industrial applications, share the common challenge of achieving high output in compact form-factors, in the most cost-effective manner. SemiLEDs' unique vertical-metal architectures allow these devices to be driven hard, without compromising either their stability or reliability, allowing packagers and integrators to deliver maximum optical power from extremely small package or chip-on-board footprints." Mr. Tuttle continued, "The EV-80 mil line is also able to deliver substantial versatility, including die-level white options that incorporate SemiLEDs' proprietary

ReadyWhite™ phosphor coating technology, which minimizes blue-leakage and delivers impressive levels of color uniformity with tight binning options for low-profile and multi-color white packaged LEDs."

The new EV-80mil ReadyWhite™ chips incorporate SemiLEDs' proprietary phosphor technology, and when packaged in a typical 5x5 mm ceramic package, can be expected to deliver up to 1200 lumens at 3 A. They are available in correlated color temperatures (CCTs) ranging from 2,600 K to 10,000 K with color rendering indices from a minimum of 65 to a minimum of 90, after packaging. Combined with their vertical LED chip architecture, SemiLEDs' ReadyWhite™ solutions deliver a package-ready white chip to COB, single-die or multi-die packaging applications, eliminating requirements for sophisticated and costly phosphor manufacturing technology. When driven with currents below 1.0 A, with the 80 mil ReadyWhite chips deliver up to 145 cool white lumens per watt in typical package configurations, and are suited for such applications as outdoor street or area lighting, or heavy duty flashlights/torches.

The 80 mil blue chips are available in standard wavelengths from 445 nm to 460 nm, with options up to 470 nm additionally available upon request, and deliver up to 4,000 mW of optical power at 450 nm in typical ceramic packaging. As single-chip implementations, the ReadyWhite and blue chips are ideally suited to narrow beam pattern kilolumen applications that benefit from simplified optics and compact emitter sizes, including projectors, MR/GU/PAR spotlights, and automotive front lighting. The reduced chip count from the larger devices also simplifies system architectures for high-bay and other multi-die kilolumen applications.

"While much of the news in the LED industry is focused on general lighting, there is an incredible amount of innovation going on in the industrial and medical arenas," continued Mr. Tuttle. "The 80 mil UV solution from SemiLEDs allows tremendous power per square millimeter for high output-density industrial requirements. Applications ranging from spot curing to 3D printing and fiber optic coupled systems, as well as completely new applications, are all benefitting from the increased optical control that is enabled by solid state solutions such as SemiLEDs single-die 80mil series," he stated.

The UV 80mil is offered in wavelengths ranging from 360 nm to 420 nm with optical outputs up to 4,000 mW when driven at 3 A in typical ceramic packages. For industrial applications, including spot curing of polymers, inks, and adhesives, to 3D printing and fiber optic coupled systems, the 80 mil design enables an 8-10 W single chip point source, eliminating the need for sophisticated optic designs to collimate light, as well as avoiding dark gaps inherent to designs that use multiple smaller chips. The single chip approach increases flexibility for varying the beam patterns through secondary optics, increases UV exposure consistency, and maximizes delivered UV optical power across the target areas. ■

Everlight Adds High Voltage Version to XI3030 LED Series

Everlight Electronics, a leading player in the global LED and optoelectronics industry, announces the XI3030 High Voltage series, an addition to Everlight's popular XI3030 mid to high power LED package. By introducing the High Voltage version, a new concept of the existing XI3030 series with higher voltages at a lower price, Everlight aims at reducing manufacturers' total lamp or fixture costs. The XI3030 HV LED is a half to full watt LED that has a 30 V version available, with other voltages upon request.



Everlight now has a XI3030 series 0.5 W to 1 W 30 V LED version available; other voltages on request

High Voltage LEDs, when used correctly, simplify driver designs by reducing the voltage difference between the AC input line voltage of the completed product and the DC input voltage to the LED components. This not only reduces the number and cost of driver components needed but improves driver efficiency. Thus producing a more efficient, more cost effective total solution.

NEW PRODUCTS



LL01CR-AVC30L06-M2

DxH(mm) 28.8x15.95
FWHM 30°
Cree XPE



LL01NI-BNX38L02

DxH(mm) 44x14.6
FWHM 38°
Nichia 757x7



LL60CR-BOQ30L02

DxH(mm) 215.6x11.8
FWHM 30°
Cree XPE

LL01LU-BRS24R49

DxH(mm) 90x50
FWHM 24°
Luminus CXM-18
Holder: LL01A00BVFB2-M2



4 in 1 Street lighting lens (Developing)

LxW(mm) 50x50

Type II

Cree XPE, XPG, XPG2, XTE, XPL
Osram Oslon square
Nichia NVS19
LGIT Ceramic 3535

Type III

Cree XPE, XPG2, XTE, XPL
Osram Oslon square
Nichia NVS19
Lumileds Rebel ES
LGIT Ceramic 3535



4 IN 1 LENS HOLDER (Can be compatible to DF, BDF & AAF series Lens)

CREE XBD

LL01CR-BDFxxL06 (Full angle 25° 40° 60°)
LL01CR-DFxxL06 (Full angle 100° 30°x65°)
LL01NI-AAFxxL02 (FWHM 45° 60°)

CREE XPE2

LL01CR-BDFxxL06 (Full angle 25° 40° 60°)
LL01CR-DFxxL06 (Full angle 100° 30°x65°)
LL01CR-AAF25L02 (FWHM 25°)
LL01NI-AAF45L02 (FWHM 45°)

CREE XPE

LL01CR-BDFxxL06 (Full angle 25° 60°)
LL01CR-DFxxL06 (Full angle 100° 30°x65°)
LL01CR-AAF25L02 (FWHM 25°)
LL01NI-AAFxxL02 (FWHM 45° 60°)

TSMC TH3, TH5

LL01CR-BDF40L06 (Full angle 40°)
LL01CR-DF100L06 (Full angle 100°)
LL01CR-AAF25L02 (FWHM 25°)
LL01NI-AAFxxL02 (FWHM 45° 60°)



Holder: LL04CRSW40H2
DxH(mm) 37x10.61

Our Services



► R & D ► Precision Mould ► Manufacture ► Component solution
► Customerization

Further technical information is available, please contact us for more details.

www.ledlink-optics.com | service@ledlink-optics.com

The performance level of Everlight's new high voltage XI3030 HV series meets all application requirements and achieves an efficiency of around 120 lm/W at 3000K CCT, 80 Ra minimum and 115 lm brightness. It is available either with 7-step ANSI-bin or 3-step central bin. LM80 is under process. Everlight's XI3030 package is Pb-free, halogen-free and RoHS compliant.

In line with Everlight's campaign of "The Right LED for the Right Application", the XI series High Voltage LED can be used as different cluster configurations in applications such as LED bulbs, LED lamps, LED down lights, and LED flood lights to optimize cost versus performance of each of those applications. ■

Philips Lumileds Introduces Luxeon CoB with CrispWhite Technology

Philips Lumileds launches its proprietary CrispWhite Technology, yet another quality of light breakthrough in its portfolio, making whites appear vivid and bright while colors appear saturated. Luxeon CoB arrays with CrispWhite Technology are game-changing for retail downlights and spotlights, resulting in more inviting and attractive displays.



Philips Lumileds added a second blue peak in the spectrum (~410 nm) of the Luxeon Crisp-White CoB to keep the high CRI and enhance the white perception

Key Applications:

- Downlight
- High Bay & Low Bay
- Lamps
- Spotlight

Features:

- 90 CRI with CrispWhite Technology
- Hot targeted within a 3 SDCM below BBL
- Creating a second blue peak (~410-415 nm) in the spectrum
- Efficacies of >90 lm/W
- Lumen packages from 1,000 to >5,000
- Tested at Tj = 85°C
- Robust MCPCB solution
- Mousebites for M2/M3 screws

Proper lighting is central to the perception and evaluation of goods. It is a critical component of branding, highlighting and presenting merchandise and creating a space where shoppers want to visit. With CrispWhite Technology, all colors, including the white, show the best saturation, just like daylight. And unlike CDM solutions, Luxeon CoB with CrispWhite Technology turns on instantly, which is a compelling advantage for retail lighting applications.

"CrispWhite really delivers the light quality that retailers have been seeking for some time," said Eric Senders, Product Line Director, Philips Lumileds. "Shop owners have told us that CDM sources do a fine job of rendering warm colors but they would like to save energy and take advantage of the longer lifetime of LEDs." Just like CDMs, the new CrispWhite LEDs maintain high CRI and bring out the white color in merchandise by utilizing a second peak in the blue spectrum. This approach creates the optimal illumination for retail displays.

Luxeon CoB with CrispWhite Technology is available in multiple lumen packages, from 800 lumens for MR16 and PAR lamps, all the way up to 7000 lumens to replace 70 W and 100 W CDM solutions. ■

SSC Introduces Acrich Module for Omnidirectional Bulbs

Seoul Semiconductor, a global leader in LED technology, announced the release of a new Acrich module designed for omnidirectional lamps. This new module is comprised of the Acrich MJT 2525 series LED along with Seoul Semiconductor's latest generation of Acrich3 driver IC and a reflector optic.



Conventional LED bulb VS omni-directional LED bulb with Acrich MJT 2525 Module applied

Features:

- Acrich Module with MJT 2525 series LED and Acrich3 driver IC
- Easy-to-use solution optimized for omnidirectional lamps to meet ENERGY STAR® requirements
- Incorporates Seoul Semiconductor's proprietary Acrich Multi-Junction (MJT) chip technology
- Acrich3 driver IC solution designed to work with most existing TRIAC or phase-controlled dimmers

The Acrich MJT 2525 series LED with dimensions of 2.5 mm x 2.5 mm and a wide beam angle has industry leading lumen density of 15 lm/mm². It incorporates Seoul Semiconductor's proprietary Acrich Multi-Junction chip technology to create the high voltage LED package. The Acrich3 IC is the



LED Optics Made from Glass: The Intelligent Choice

Rely on the advantages of our optics made from glass: Temperature and UV resistance, stability and a long service life.

See for yourself at **LpS 2014, Bregenz, Stand A21**

auer
LIGHTING

www.auer-lighting.com/led



> BIG IDEAS IN MIND?

Make them a reality with
our lighting innovations

See your big lighting ideas become big successes with Toshiba's solutions support. Our technology lies behind many of the latest developments in lighting. Like using silicon instead of sapphire substrates for all our white LEDs, including the new ultra small CSP products.

And we can also help to make your big ideas reality with our range of MOSFETS, photocouplers and photorelays. So whatever you have in mind, our range of lighting innovations is here to help you take it to the next level.

www.toshiba-components.com

TOSHIBA
Leading Innovation >>>

ARROW | Lighting

Transforming Solid-State Lighting—Five Years Out

Where ever you are in the design process, we can help you access the world's leading SSL technology, select and source the best materials, design and engineer for speed to market produce the modules you need, and manage your supply chain.

Our engineers, designers, and innovators are working to help make the world of Five Years Out brighter than ever before.

Are you Five Years Out?

Then you're probably working with us.

V | Five Years Out

Visit us
booth N3-N4-N5

LpS 2014
Bregenz
Austria

30 Sept - 2 Oct

lighting-europe.arrow.com



latest generation driver IC that can work directly from the AC mains. It enables lower cost driver solutions and is designed to work with existing TRIAC or phase-controlled dimmers without sacrificing on power quality or efficiency. All LEDs and the driver IC are incorporated on one single board, 38 mm diameter, making the light engine easy to use in an A19 form factor.

Along with the light engine comes an innovative reflector solution that has been optimized to create the omnidirectionality of the light pattern. An optional heat bridge could also be used to improve thermal dissipation of the light engine. ■

LeDiamond Opto Introduces New Tesla 2903 7in1 Module

LeDiamond Opto Corp, a leading LED filament manufacturer from Taiwan, has announced its new Tesla 2903 7in1 module. Tesla 2903 7in1 is a double-side emitting LED product which is suitable for lighting fixtures that need lighting up and down, such as office pendant or wall lamp.

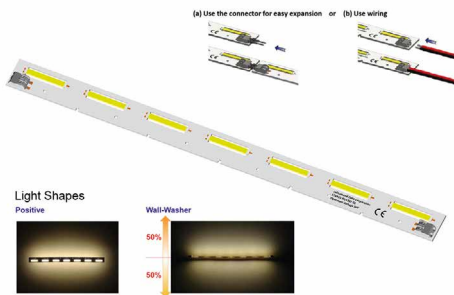

LeDiamond's Tesla 2903 7in1 Module is actually composed by Tesla 2903 filaments which deliver 160 lm/W at 2700 K and CRI 80. It also has an LM80 report

LeDiamond Tesla 2903 7in1 module uses WAGO connector or wires for easy expansion on its length; also by using a supporter with

screws can expand its width. Tesla 2903 7in1 module is a unique product; it can provide you quick assembly and reliable performance.

The Tesla 2903 7in1 Module is actually composed by Tesla 2903 filament which has LM80 report in comparison with others. Besides, the efficiency of the filament is 160 lm/W@2700K and CRI 80, which is the highest mass production standard compared to other filaments. By using Tesla 1505 4in1 module in candle light can reach 500 hot lm, and using Tesla 2903 4in1 module in A19 can reach 700 hot lm. ■

LEDiL Introduces Winnie for Compact MR16 Designs

The new Winnie family from LEDiL features unique folded TIR design which substantially reduces height compared to traditional collimating optical designs. Winnie features convenient MR16 size for a range of luminaire or retrofit designs and can be used with heat sinks pre-drilled for Zhaga compatible light engines. Highly efficient design, typical efficiency close to 90%. The spot version has a beam angle of around 20 degrees, subject to the LES size. Medium and wide flood beams to follow soon.



Winnie, LEDiLs latest optics, is especially designed for high quality MR16 applications

Features:

- PMMA lens for a range of COB's with LES size up to 21 mm
- Hyper-reflective white PC holder and optical grade PMMA for high efficiency
- Unique flat folded TIR design
- Zhaga Book 3 compatible fastening – pre-drilled heatsink available
- Designed to work with the range of COBs from brands like Cree, Citizen, Osram and Bridgelux

Applications:

- Track lighting luminaires
- Retrofits
- Downlights
- Indoor and outdoor spotlights

CN14236_Winnie-S - Specifications:

- Height: 19,3 mm
- Diameter: 49,8 mm
- Beam type: Spot
- Typical FWHM 22°
- Typical efficiency 87%
- Precision-molded from optical grade PMMA – UL94 HB rated material with operating rating -40°C to +80°C

Additionally Winnie-M (FWHM ≈35°) and Winnie-W (FWHM ≈50°) are in preparation and will be coming soon.

Additional recent product release:

Jenny - a cost effective silicone lens family:

LEDiL the first optics company in the world to launch a mass-produced commercially available state of the art silicone optic for the light emitting diode market now expands its clan of silicone optics by introducing Jenny – a cost effective silicone lens family designed for a range of smaller LES sizes CoBs from brands like Cree, Osram and Citizen.

Designed to be used as single optics or in array configurations Jenny is available as a single lens or in a 8X1 module. Jenny-8X1 modules can easily be cut into smaller configurations. Jenny features easy positioning with pins and installation by gluing or with additional holder. ■

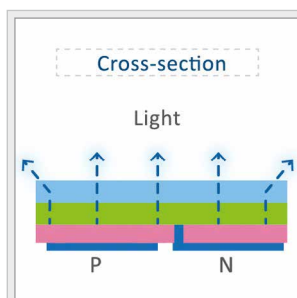

Pad Extension Chip

EPISTAR's PEC promotes the next generation of lighting applications with the advantages of higher package density and driving current.

Features:

Large PN bond pads with AuSn / Low forward voltage / Low thermal resistance / High driving current / No need of wire bonding

EPISTAR
sales@epistar.com.tw

Lextar
Lextar Electronics

The True Vertical Integrator

In-house epi, chip and package giving start-to-end control to your LEDs



Lextar.com
Sales.LT@Lextar.com



Visit us! 10/27 - 10/30
Hall 1 1A F22

DANGOO

THE REINVENTION OF THE EDISON BULB

LED FILAMENT™

- Traditional incandescent bulb light effect
- Real Omni-directional light distribution
- Unique manufacturing process with flip chip technology
- 40% more efficiency than traditional LED solutions: >120 lm/W
- Light weight, no metallic heat sink
- Largest installed production base on the industry
- Wide patent portfolio
- CE (LVD/EMC/RoHS/Erp) compliant
- Explosion-proof film on surface of glass cover to pass UL certification



Dangoo Electronics
www.dangoo.com.cn
info@dangoo.com.cn
Tel: +86 (21) 5426 4988
Fax: +86 (21) 5426 4977

Lighting Solutions | LED Bulbs | LED Fixtures

Global Offices:
Asia | USA | Europe



RELIABLE CAPACITOR DESIGNS FOR LONG LIFE LED'S & DRIVERS

ISOLATED SWITCH CONVERTOR WITH TRANSFORMER AS STORAGE COMPONENT

PRIMARY VOLTAGE AC INPUT

- High Vdc/ Low Cap (500V–1000V) Holy Stone **HVC Series**
- Low Vdc/ High Cap (1μF–10μF) Holy Stone **HCC Series**
- Low Vdc/ Low Cap (pF–nF range) Holy Stone **NCC Series**

SECONDARY VOLTAGE LED

- High Vdc/ Low Cap (100V–500V) Holy Stone **HVC Series**
- Low Vdc/ High Cap (1μF–47μF) Holy Stone **HCC Series**

NON-ISOLATED SWITCH CONVERTOR WITH INDUCTOR AS STORAGE COMPONENT

PRIMARY VOLTAGE AC INPUT

- High Vdc/ Low Cap (500V–1000V) Holy Stone **HVC Series**
- Low Vdc/ High Cap (1μF–10μF) Holy Stone **HCC Series**
- Low Vdc/ Low Cap (pF–nF range) Holy Stone **NCC Series**

SECONDARY VOLTAGE LED

- Low Vdc/ High Cap (1μF–47μF) Holy Stone **HCC Series**

NON-ISOLATED LINEAR CONVERTOR WITH CAPACITOR FOR FILTERING & STORAGE

PRIMARY VOLTAGE AC INPUT

- High Vdc/ Low Cap (500V–1000V) Holy Stone **HVC Series**
- Low Vdc/ High Cap (1μF–10μF) Holy Stone **HCC Series**

SECONDARY VOLTAGE LED

- High Vdc/ High Cap (100V–250V) <47μF Holy Stone **HVC Series**



Holy Stone Enterprise Co., Ltd.

Tel: 951-696-4300
Fax: 951-696-4301

info@holystonecaps.com
www.holystonecaps.com

Europe: www.holystoneurope.com

Asia: www.holystone.com.tw

Cost-Effective Triac Dimmable LED Driver IC from Diodes

Diodes Inc., a leading global manufacturer and supplier of high-quality application specific standard products within the broad discrete, logic and analog semiconductor markets, introduced the AP1695. This LED lamp driver optimizes the design of sub 12 W triac dimmer-compatible LED lamps by featuring a dimming range of 1 to 100% and up to a 30% reduction in bill of materials (BOM) cost.

AP1695 Advantages:

- Unique Constant On Time (COT) Control Expands range of compatible dimmers; and can be triac dim down to 1%
- Single stage high PF triac dimming solution with reduced number of external components Low BOM solution cost
- Supports non-isolated Buck (120 VAC and 230 VAC) and Buck-boost Flyback solutions (120 VAC)
- One device can meet the different isolation/cost needs of different lamps
- Boundary Conduction Mode (BCM) Operation Achieved higher convert efficiency and reduced EMI issues with fewer components
- Integration MOSFET support <10W LED lamps with Low BOM cost and small PCB size

Features:

- Boundary Conduction Mode (BCM) Operation for high efficiency
- High PF and low THD (PF >0.9, THD <30%)
- High efficiency without dimmer
- Wide range of dimmer compatibility
- Dimming curve compliant with NEMA SSL6
- Low start-up current
- Tight LED current
- Tight LED open voltage
- Valley-mode switching to minimize the transition loss
- Internal integrated 2 A / 500 V MOSFET can cover up to 10 W
- Easy EMI
- Internal protections: Under Voltage Lock Out (UVLO) / Leading-edge Blanking (LEB) / Output short protection / Output open protection / Over temperature protection
- Flexible for design with small form factor and very low BOM cost
- Totally lead-free & fully RoHS compliant
- Halogen and antimony free. "green" device

For 120 V and 230 V mains-dimmable retrofit LED lamps such as the common 5 W GU10 and 8 W energy saver bulbs, the high-performance AP1695 uses a patented constant on-time control technique to enable deep triac dimming down to 1% and an increase in lamp/triac compatibility. Its dimming curve complies with the NEMA SSL6 standard and the driver is fully compliant with the requirements of the IEC6100-3-2 harmonic standard. ■

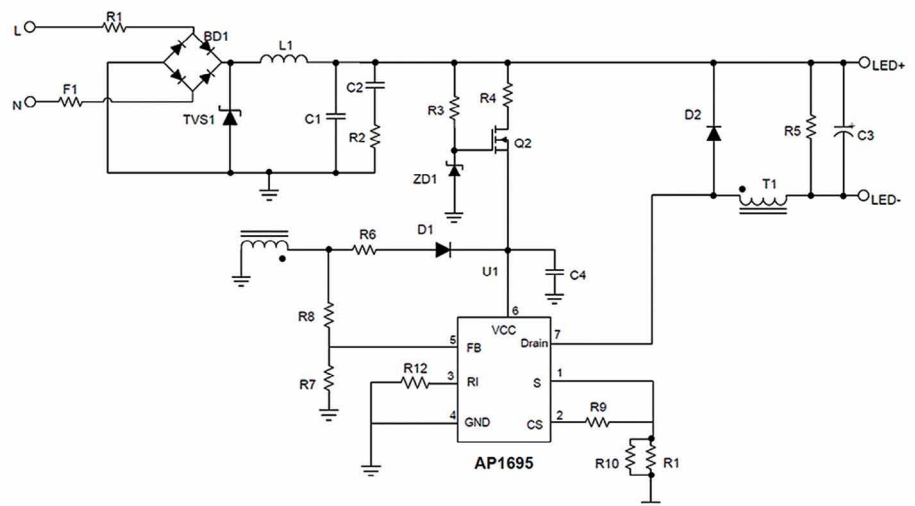

Typical application circuit of an LED driver buck solution using the Diodes AP1695 driver IC

Wherever things get hot

CeramBright Modules

Plug & Light system for interior and exterior lighting. LED cooling at its best.

LpS 2014
LED SYMPOSIUM
EXPO

LED & OLED Lighting
Technology
SEPT 30th - OCT 2nd 2014 | BREGENZ | AUSTRIA

VISIT US:

LED professional Symposium & Exhibition 2014 - booth C18



CeramTec GmbH
Phone +49.9231.69387
Fax +49.9231.69-68387
E-Mail lighting_applications@ceramtec.de
www.ceramtec.com/ceramcool

CeramTec
THE CERAMIC EXPERTS



New Multi-TIR Nested Lens Technology for COB LEDs

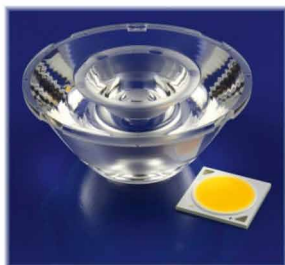

Fraen's low profile, multi-TIR nested lens delivers narrow beam lighting when used with a variety of Chip-On-Board (COB) LEDs.

- Full control of the LED radiation pattern
- Highest center-beam candela per lumen
- Reduced off-axis glare
- Reduced overall optic height

Fraen's Patent Pending nested TIR lens technology is the ideal solution for COB LED applications, especially where narrow beam illumination patterns are required.

optics@fraen.com
www.fraen.com



Die Details im Visier, das System im Blick

Eine perfekte Lösung beginnt bei zuverlässigen Komponenten, die jede für sich präzise und effektiv arbeitet. Von LED-Modulen und LED-Konvertern über Notlicht und Lichtsteuerungen: Tridonic bietet Ihnen die gesamte Produktvielfalt aus einer Hand – individuell kombinierbar, bis hin zum kompletten Lösungspaket für die Anwendung. Wir nehmen ihre Anforderungen bis ins kleinste Detail ins Visier und behalten dabei das gesamte System im Blick.

www.tridonic.com

MeanWell's New LED Drivers have Low No-Load Power Consumption

Thanks to the market trend of green and environmental protection, there has been an explosive growth of the demand for LED in the lighting industry. Meanwhile, there are always new lighting applications with respect to LED being unveiled, and the worldwide safety or energy regulations for LED luminary continue to be updated. In order to fulfill the market need, MeanWell releases the new 90W single output LED power supply with active PFC function ~ NPF-90, NPF-90D and PWM-90 series.



One of the outstanding features of the new LED driver series is their low no-load power consumption of 0.5 respectively 0.15 W

Completely satisfying the global energy saving concern for luminaries, these three series all come with the setup time less than 500 ms, the no load power consumption less than 0.5 W (for NPF-90, it is less than 0.15 W) and the built-in active PFC function. Here is the highlight for each individual series: NPF-90 exploits the “constant voltage (CV) + constant current (CC) mode” design that allows this series to work ideally for the major LED lighting application; NPF-90D further provides the 3 in 1 dimming function that the lighting fixture designers are able to adjust the light intensity via 0~10 VDC, PWM signal, or resistance and realize further energy saving; PWM-90 provides the “constant voltage mode” design and the PWM style output as well as the 2 in 1 dimming function (0~10 VDC or PWM signal) that enables this series to work perfectly with LED strips or the LED luminaries using current limiting resistors and supply the complete dimming function at the same time.

NPF-90, NPF-90D and PWM-90 are all Class II power unit (no FG). The input end accepts the full range 90~305VAC, and the output end supplies the DC voltage that the LED lighting units or strips use the most frequently. These three series all adopt the 94V-0 flame retardant plastic enclosure, and the interior is fully filled with heat conductive silicone; in addition, the working efficiency is high up to 91% that they can operate between -40°C and +70°C under free air convection. The thorough protection functions include short circuit protection, overload or over current protection, over voltage protection, and over temperature protection. NPF-90, NPF-90D and PWM-90 series are certified with the major international regulation standards such as UL8750 and EN61347-1, and the circuit design refers to the safety norm of household electrical appliances, EN60335-1, providing high flexibility for lighting system design. Suitable applications include indoor LED lighting, LED decorative lighting, LED architecture lighting. ■

ETΦ™ LED Characterization System

Electrical - Thermal - Optical testing and product design using LEDs - now simpler than ever

- Fully automated data collection and analysis tools
- Highly accurate LED spectral flux measurements
- TEC temp control with Ts, Tc, Tj monitoring
- Single Pulse, DC & PWM power control
- Test & Measure LEDs up to 200W

Orb Optronix/CSA Group (425) 605-8500 sales@orboptronix.com

High Wattage AC or DC Input LED Drivers Introduced By Thomas Research Products

Thomas Research Products has introduced new high wattage LED Drivers designed to accept DC or AC input. Thomas Research Products is a leading manufacturer of SSL power solutions.



TRP's new PLEDDC LED drivers are a high power driver series offering the same performance as the popular PLD series

The new PLEDDC series 120 W, 150 W and 200 W drivers are based on TRP's popular high performance PLED series models. Right out of the box, these units accept universal 100-277 VAC input or 108-250 VDC input with no modification. They provide flicker-free output.

Models are available in constant-current, dimming, and constant-voltage versions. TRP's new drivers offer all the same features as their regular PLED drivers, including Black Magic Thermal Advantage(TM) aluminum enclosures. They are also IP66, rated for dry and damp locations.

All LED Drivers from TRP offer high quality, long life, and high efficiency and are cost-competitive. Information can be found on the company's website. PLEDDC series drivers are available now and carry the company's standard 5 year warranty. ■

EPtronics - New 25 W and 40 W HL Rated Dimmable LED Drivers

EPtronics, Inc has introduced a new line of 25 W and 40 W UL recognized LED drivers which are made to withstand hazardous locations. These drivers are intended to be installed in hazardous (classified) location areas without needing further evaluation.



EPtronics now offers their LDHL25W & LDHL40W LED driver series also for use in hazardous locations

The LDHL LED Driver Series offers efficient and proven constant current or constant voltage designs that feature dimmable (PD for PWM dimming, RD for 0-10 V dimming)

and non-dimmable options. The 25 W driver's input voltage range is 90-305 VAC and the output voltage range is 4-72 VDC with output currents ranging from 350 mA to 2080 mA. The 40 W driver's input voltage range is 90-305 VAC and the output voltage range is 3-140 VDC with output currents ranging from 300-4450 mA. These new drivers are fully encapsulated in black 5 VA (UL 94 Flame Rating) plastic casing which adds internal thermal protection. This feature certifies the drivers to receive Type HL rating from UL. These drivers are rated IP66 and can withstand dry and damp conditions. ■

GWP Offers New Compact 18 W LED Power Supply

Green Watt Power announces the compact 18 Watt GLCA Series. These constant current LED power supplies offer a more compact solution over the standard Green Watt Power 18 Watt GLC Series which makes the GLCA ideal for space constrained applications.



GWP's GLCA series is the more compact version of the GLC standard series

Main Features:

- Universal AC Input / Full Range (100-305 VAC)
- 100-277 VAC Input for North America
- CSA/UL Approved
- CE Approved
- High Reliability
- Efficiency up to 80%
- Over Voltage Protection
- Short Circuit Protection
- Over Current Protection
- Over Temperature Protection
- Waterproof IP67
- RoHS Compliant
- 5 Year Warranty

fischer
elektronik →

to cool to protect to connect

Electromechanics for LEDs

- various LED heatsinks
- versatile thermal conductive materials
- LED connectors for LED-line module and PCB
- special solutions and versions for your special application



For more details please check our website:
www.fischerelektronik.de

Fischer Elektronik GmbH & Co. KG

Nottebohmstraße 28
D-58511 Lüdenscheid
Phone +49 (0) 23 51 43 5-0
Fax +49 (0) 23 51 4 57 54
E-mail info@fischerelektronik.de



We exhibit:
LED Professional
Symposium + Expo in Bregenz
30.09.-02.10.2014
stand A16

The GLCA has a universal input range of 100 to 305 VAC and offers output currents of 350, 500 and 700 mA. The voltage range for the 350 mA model is 35 to 52 V. The 500 mA model has a 28 to 36 V range and the 700 mA offers an 18 to 30 V range. All models are CSA/UL and CE approved.

The dimensions of the GLCA are 3.43x1.65x1.08 inch. The 3.43" dimension includes the mounting flanges. It is fully encapsulated with an IP67 rating. The unit weight is 0.18 Kg. The operating temperature range is -20° to +60°C. All models are RoHS compliant.

The Power Factor Correction for the GLCA is 0.90. Noise and Ripple is 5% maximum. Total Harmonic Distortion is less than 20% for all models. Setup Time is 1.5 s and Rise Time is 200 ms. The Overshoot and Undershoot Response is +/-10%. Input current is 0.4 A at 110 VAC with a full load condition. All models are protected with over voltage protection, short circuit protection, over current protection and over temperature protection. ■

MechaTronix's New Passive Cooler Challenges Active LED Cooling

Just a few years ago it was hardly possible to develop a down or spot light with light output over 3000 lumen without using an active fan or blower LED cooler. With the latest generation LED modules and COBs the efficacies and internal thermal resistances have dramatically improved. The result is that even a 4500 lumen shop light can easily be kept at its ideal temperature with a well-designed passive LED cooler.

"Changing over from active to passive LED cooling does not only bring an immediate cost reduction on the cooler itself, it also eliminates the need of a more complex and expensive LED driver, brings the noise to zero and reduces the risks of breakage that an active element always poses. The only reason why many designers are still using the same active cooler as a few years ago was the lack of good passive alternatives which also mechanically fit in their current designs" said Koen Vangorp, General Manager at MechaTronix.



MechaTronix's latest passive heat sink delivers a cooling performance that makes active cooling obsolete in many cases

For that reason, MechaTronix has developed the ModuLED Micro. This passive star shaped LED cooler is specifically developed in a diameter of 86 millimeter - similar to most active coolers on the market. The MechaTronix designers were aware that mechanical adaptations in an existing luminaire are not always easy to do, and have incorporated in that way a mechanical design which allows 1-to-1 replacements. Although the mechanical compatibility of the design has a completely different behavior with regards to thermal management, the base of an active cooler only gives a good performance under forced airflow conditions. In a free air convection environment, these mechanical bases are not optimized for ideal convection and radiation cooling.

The ModuLED Micro is developed in this way that there is an ideal balance between conduction, convection and radiation, what leads to an improvement of over 20% in cooling capacity.

With 3 standard heights of 30 mm, 50 mm and 80 mm the ModuLED Micro performs a thermal resistance of 1.8°C/W, 1.5°C/W and 1.2°C/W respectively.

As an example we take the latest generation LED module of Philips Lighting, the Fortimo SLM G4 which just launched recently. The Fortimo LED SLM 4500 is a 4500 lumen package with a variety of CCT and CRI values available. In an ambient temperature of 35°C this module needs a LED cooling capacity of 1.28°C/W to maintain the junction and case temperature at the ideal design reference; making the 80 mm ModuLED Micro an ideal combination.

The ModuLED Micro is foreseen from a variety of standard mounting holes making that almost all round shaped LED modules and various CoB formats can be directly fitted on the LED cooler without the need of extra drilling and tapping. ■

Fischer Elektronik Offers a Sample Case for LED Heatsinks

The LED is used as the light of the future in almost all areas of daily life in indoor and outdoor areas. After the invention of the light bulb, no other lighting material has influenced the world of artificial light as much as the LED. "Good" light also sets itself apart through efficient thermal management in addition to the power supply used, its optics and its electronics system. The easiest and most effective way to cool all LEDs are provided by extruded and pin-fin heat sinks in a round model which are adapted to the LED dimensions.



Fischer's sample case includes the most popular heat sink types and required TIMs

For the special purpose of verifying the thermal management for LEDs, Fischer Elektronik is bringing a new sample case onto the market with the article number SK LED BOX 1. The box includes a product range with different extrusion heat sinks, round shaped LED heat sinks, LED pin-fin heat sinks and extrusion heat sinks for LED line modules. For the thermal contact or mounting the LEDs, a thermal conductive graphite foil (WLFNG), a double adhesive thermal conductive ceramic filled (WLFRT), thermal adhesive paste (WLPK), a thermal adhesive foil and a thermally conductive two-component adhesive epoxy base (WLK DK) are also included. ■



Touch the technology



GL GONIO SPECTROMETER

Introducing the latest innovation from GL Optic.

ENTER THE WORLD OF THE GONIOSPECTROMETER

GL Optic's latest innovative product combines the functionality of a goniophotometer with the features of a spectroradiometer to measure brightness and to check angle dependence luminous intensity.

Conforms the Goniospectrometric measurement on four C planes at γ angles in 10° steps according to the IES LM-79 standard:

- Angular color measurements
- Spectrometric and colorimetric measurements

www.gloptic.com

GL OPTIC Light measurement solutions

ATS Introduces New Heat Pipes to Cool at Minimal ΔT

Advanced Thermal Solutions, Inc., ATS, has introduced a series of copper heat pipes for transporting power dissipation away from hot electronic components. Thirty-three round and flat profile heat pipes are available to meet application needs.

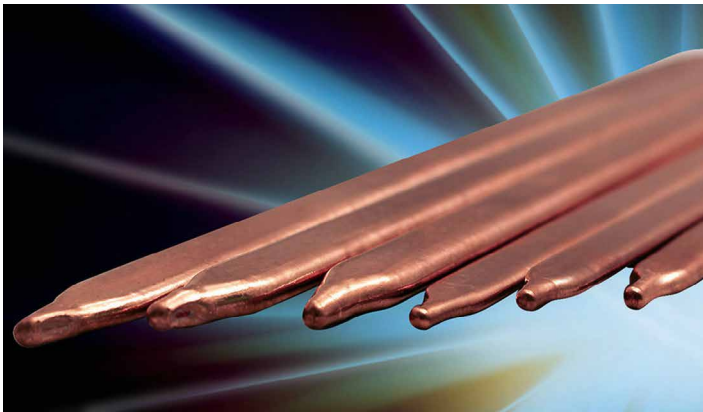

ATS' new heat pipes are effective in temperatures ranging from 30-120°C

The new ATS heat pipes transfer component heat to heat sinks with minimal temperature difference. They also distribute heat efficiently across the length of heat spreaders. Liquid in the heat pipe turns to vapor by absorbing heat and removing thermal energy from hot component surfaces. The vapor travels to the cold end of the pipe where it releases latent heat and condenses back to liquid. The liquid returns to the hot interface along an internal copper wick to provide continuous thermal management.

The cold end of the copper heat pipe attaches easily to most heat sinks, providing effective cooling when a heat sink can't be applied directly on a heat source. All heat pipes are easily hand or machine-shaped to meet application needs. They can be friction fit, clamped, soldered, or adhesively attached.



LUGA Shop Pearl White

Impress your customers with the unique light quality of LUGA Shop Pearl White, the new star on the fashion horizon and the future of shop lighting.



**Brilliant Colours
High CRI
L90/B10 | >143 lm/W**

www.vossloh-schwabe.com

Each model in the new heat pipe series has been characterized by ATS for both thermal resistance and maximum heat transport capability. The transport property is determined as a function of the working temperature and the pipe's angle of inclination.

Every heat pipe consists of a sealed copper tube, internal copper wick structure, and distilled water as its working fluid. Round profile heat pipes come in lengths from 200-300 mm and diameters from 4.0-8.0 mm. Flat profile heat pipes range in length from 100-250 mm, widths from 8.2-10.5 mm, and heights from 2.5-4.5 mm. Weights range from 8-33 grams. They are effective in temperatures ranging from 30-120°C. Other fluids and sizes can be accommodated with custom designs. ■

Nanodiamonds Increase Polymer Thermal Filler Conductivity by 20%

Carbodeon, a Finnish-based producer of functionalized nanodiamond materials, can now achieve a 20% increase in polymer thermal performance by using as little as 0.03 wt.% nanodiamond material at 45% thermal filler loading, enabling increased performance at a lower cost than with traditional fillers.



Nanodiamond enhanced polymeric heat sinks for LEDs - Improved materials and processes enable nanodiamond cost reductions of up to 70 percent for electronics and LED applications

Last October, Carbodeon published its data on thermal fillers showing that the conductivity of polyamide 66 (PA66) based thermal compound could be increased by 25% by replacing 0.1 wt.% of the typically maximum effective level of boron nitride filler (45 wt.%)

with the company's application fine-tuned nanodiamond material. The latest refinements in nanodiamond materials and compound manufacturing allow similar level performance improvements but with 70% less nanodiamond consumption and thus, greatly reduced cost.

The samples were manufactured at the VTT Technical Research Centre in Finland and their thermal performance was analyzed by ESK (3M) in Germany.

"The performance improvements achieved are derived from the extremely high thermal conductivity of diamond, our ability to optimize the nanodiamond filler affinity to applied polymers and other thermal fillers and finally, Carbodeon's improvements in nanodiamond filler agglomeration control," said Carbodeon CTO Vesa Myllymäki. "With the ability to control all these parameters, the nanotechnology key paradigm of 'less gives more' can truly be realized."

The active surface chemistry inherent in detonation-synthesized nanodiamonds has historically presented difficulties in utilizing the potential benefits of the 4-6nm particles, making them prone to agglomeration. Carbodeon optimizes this surface chemistry so that the particles are driven to disperse and to become consistently integrated throughout parent materials, especially polymers. The much-promised properties of diamond can thus be imparted to other materials with very low, and hence economic, concentrations.

For more demanding requirements, conductivity increases of as much as 100% can be achieved using 1.5% nanodiamond materials at 20% thermal filler loadings.

"This increase in thermal conductivity is achieved without affecting the electrical insulation or other mechanical properties of the material and with no or very low tool wear, making it an ideal choice for a wide range of electronics and LED applications," said Vesa Myllymäki. "We know we have not yet uncovered all the benefits that Carbodeon nanodiamonds can deliver and continue our focused application development on both polymer thermal compounds, and on metal finishing and industrial polymer coatings," Myllymäki added. ■

Isocyanate-Free Resin with Improved LED Operator Safety

Electrolube, the global manufacturer at the forefront of electro-chemicals technology, has developed a clear polyester resin that delivers the high performance of a polyurethane resin without the use of hazardous isocyanates. The flexible encapsulation resin, PE7500, completely eliminates any health risk from isocyanate exposure, proven to cause irritation to the eyes, skin and respiratory system. PE7500 therefore provides a vastly safer environment for operators, whilst also reducing ventilation issues and costs for manufacturers.



Electrolube's isocyanate-free PE7500 resin has especially been created to satisfy the needs of the LED industry

Developed specifically to offer high protection in harsh environments, PE7500 is ideal for applications where high humidity or salt mist environments exist. In addition, due to the flexibility and low shore hardness of this material it is ideal for low temperature applications and where easy removal of cured material for rework processes is required. Operating within a temperature range of -70 to +100°C and offering excellent electrical properties, the PE7500 polyester resin provides an innovative solution to low hazard potting and encapsulation applications. ■

Low Viscosity, Non-Yellowing, Optically Clear Epoxy

Master Bond EP112LS is a two part epoxy that is well suited for impregnation, potting, encapsulation, sealing and coating applications, particularly in the aerospace and optoelectronics industries.



Signcomplex | We bring innovation and give inspiration



Hong Kong International Lighting Fair
(Autumn Edition)

Date: 27-30 Oct, 2014

Booth No.: 5E-C01



light

MIDDLE EAST

Date: 3-5 November 2014, Dubai.

Booth No.: LT631

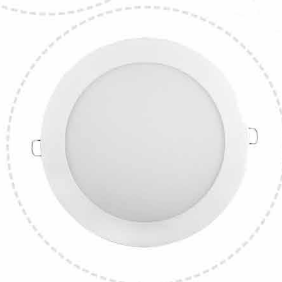

Signcomplex Limited
www.signcomplex.com
marketing@signcomplex.com
phone: +86 755 2760 8650
fax: +86 755 2760 8651



Master Bond EP112LS is a two part epoxy that is well suited for a multitude of applications, especially in aerospace and optoelectronics

EP112LS is optically clear, features reliable non-yellowing properties and has a refractive index of 1.55. This electrically insulative system is resistant to chemicals including water, oils, fuels, acids and bases. EP112LS is serviceable over the temperature range of -60°F to +450°F.

This system features a working life exceeding 2-3 days at room temperature and requires oven curing. Post curing will enhance its properties. With a mixed viscosity of 50 cps to 200 cps, EP112LS bonds well to a wide variety of substrates, including metals, composites, glass, ceramics and many rubbers and plastics. Bonds feature a tensile strength, compressive strength and tensile modulus of 11,000 psi, 20,000 psi and 400,000 psi at room temperature, respectively. Dimensional stability is outstanding.

EP112LS has a shelf life of one year in original, unopened containers. It has been formulated for a variety of high performance applications. This two component, heat-curing system is also a competent electrical insulator, even at elevated temperatures. ■

Winsun Releases Smart Dimmable GU10 LED Lamps

Shanghai Winsun is proud to announce the release of new innovative smart dimmable A++ 5 W, 5.8 W and CoB 6.8 W GU10, with industry-leading real output lumens. 5 W - 470 lm, 5.8 W - 560 lm, CoB 6.8 W - 630 lm, CRI 95 or CRI 85 customized.

They are compatible with almost all TRIAC dimmers or dimming systems. 80% Energy-saving, no blue light reveal and high quality light source gives you a high quality life.

Apart from that, a lower priced, non-dimmable version with the same ultrahigh lumens is also available.



Winsun new innovative smart dimmable A++ 5 W 470LM, 5.8 W 560LM and CoB 6.8 W 630LM Cute GU10 powered by Nichia LED, High CRI 95 or CRI 85 customized

Features:

- Nichia latest SMD757 and CoB LED 100% original from Japan
- Leading industry lumens output with efficiency even up to as high as 97 lm/W
- CRI 85 and CRI 95 even at same price.
- Perfect 5%-100% TRIAC dimmable with most trailing or leading edge dimming systems or dimmers
- Full range 2400 K, 2700 K, 3000 K, 4000 K and 5000 K color temperature optional
- EMC, LVD (certificate NO.: SHES140200042201LMC), SAA (certificate NO.: SGS/140205) approved by SGS
- 3 YEARS warranty

The lighting world is undergoing an evolution, and Winsun is at the forefront of this evolution. New generation lighting demands a combination of exceptional color rendering, high brightness, high reliability, long life and energy conservation. Perfect environmentally friendly investment, Winsun's new GU10 lamps deliver on all these demands.

5 W 470 lm GU10 is a complete retrofit of 35 W GU10, most exacting standards measuring 49.8x59 mm. Utilizing high quality genuine NichiaLED lasting 40,000 hours and requiring no ballast upkeep or maintenance costs. "I really like this cute design, they are just like artwork. Most important is that it has a really good dimming effect," said one of our customers in Australia. To meet more customers' needs: CRI95 is also available, which with a better saturation level, can better present the true color of the

object in nature. Meanwhile the 5.8 W 560 lm GU10, 97 lm/W (CCT: 3000 K) high efficiency makes it reach up to A++ energy efficiency class. Most exacting standards with the dimension of A49.8x58 mm directly replace of 50 W Halogen. CoB 6.8 W 630 lm GU10 adopted Nichia's latest CoB led, 3000 K reaches up to 90 lm/W, 5000 K of 93 lm/W. 25° and 36° for choice, exacting size of A49.8x59 mm, totally retrofit for 50 W halogen. All these three new lamps are able to smart dim down to 5% with most trailing edge or leading edge dimmers and dimming systems, smooth dimmable effect without any flickering. ■

GE Announces "Link", a Smart ZigBee LightLink LED Bulb

GE unveiled Link, a new and affordable connected LED bulb that lets consumers remotely control their home lighting from anywhere in the world and sync with other connected devices. Enabled by the new Wink app, Link eliminates the need for expensive add-ons typically associated with connected devices, making it an easy and cost-effective way for consumers to light up their smart homes. Consumers can find Link in The Home Depot stores beginning this fall.



GE's Link bulb offers lowest price point for consumers to remotely control lighting from anywhere enabled by the new Wink app

The new GE Link connected LED 60-watt replacement (A19) bulb, enabled by the new Wink app, lets consumers remotely control their home lighting from anywhere in the world while providing the same quality lighting, energy efficiency and long life that consumers expect from the GE brand.

Link provides the same high-quality lighting, energy efficiency and long life that consumers expect from the GE brand.



More new products
More new technologies
More added every day

Authorised distributor of semiconductors
and electronic components for design engineers.



**MOUSER
ELECTRONICS**

GE Link is available in three popular lighting applications:

- 60-watt replacement soft white (2700 K) LED bulb, or A19 shape, commonly used for general lighting in table and floor lamps
- Indoor soft white (2700 K) floodlight LED, or BR30 shape, installed as downlighting found in dining room, living room or other entertainment spaces
- Indoor/outdoor-rated bright white (3000 K) spotlight LED, or PAR 38, used for outdoor security or spotlight

Initial education of the benefits to a smart home will be key for driving adoption. Running off a connected hub, ZigBee-certified Link LED bulbs help consumers to save money by switching off lamps from a smartphone being on the way, to create a personal lighting experience by easily adjusting brightness settings through the Wink app to create individual themes and environments, and “vacation smarter” by turning specific lights on to give the appearance that someone is home while being away from home for an extended period. ■

ALTLED Introduces New IP65 Waterproof T8 Tubes

The ALTLED IP65 Waterproof T8 tube is high-quality, durable and especially good for bright and evenly spread illumination. Unlike traditional fluorescent T8 tubes which are fragile, the ALTLED T8 tubes are impact-resistant and shatterproof which makes it difficult to break either accidentally or through vandalism.



ALTLED's LED T8 tubes with IP65 may be applied without waterproof lighting fixtures

The ALTLED IP65 Waterproof T8 tubes come in various lengths, from 1 ft – 8 ft, and also work in extreme temperatures from minus 65°C to over 50°C to even 70°C.

An IP65 Ingress Protection rating in this ALTLED IP65 Waterproof T8 tube provides evidence of its dust-tightness and complete resistance to rain and jets of water. This means you can wet-clean this fitting, which extends its usefulness in wet areas such as shower rooms and washrooms.

With IP65, the LED T8 tubes may be applied without the waterproof lighting fixture needed for fluorescent or standard LED T8 tubes. Other possible environments include corridors, offices, refrigeration systems, warehouses, car wash, underground car parks, tunnels, and most types of outdoor use. They offer excellent performance with none of the flickering or humming sometimes associated with traditional fluorescent T8 tubes or low-cost LED brands. Another advantage includes instantaneous start-up and a significantly increased lamp lifespan. ■



HONGLITRONIC 280 nm Deep UV LEDs - UC3535

Honglitronic 280 nm deep UV LEDs - UC3535 - main specifications:
Peak wavelength: 280 nm - Forward voltage: 6 V - Optical power: 1.0 mW - Viewing angle 120°

Anti-vulcanization, Reflow Solderable, RoHS compliant.

Applications: Fluorescent spectroscopy, Sensors and monitors, Bio-analysis/detection, Phototherapy, Disinfection.

For more information, please visit en.honglitronic.com



sales@honglitronic.com



New Designed LED Strip with High Brightness and High CRI

Willighting announced a new leading product - high brightness 1500 lm/pc at 10 W and 33.5 VDC, high CRI80/CRI90. The light is quite even and there is no dimness on either of the two sides. The strip is wireless. Connectors can be used to connect it, which is quite convenient for installation.

A good choice for an aluminum profile.

Please visit www.willighting.com to learn more.



Lifud High Performance Flicker-Free LED Drivers

Flicker free LED drivers, low output ripple;
Output power range 20 W-80 W, plastic cases of unique design;
ERP and Energy Star standards;
CE, CB, ENEC, PSE, SAA, CB, UL, FCC, cUL certifications;
Both 1-10V dimmable and non-dimmable versions are available;
Designed for LED down lights, ceiling lights and panel lights, and etc.

For more details please visit <http://www.lifud.com/En/index.aspx>



sales@ledfriend.com

Best Ever RPCVD (p-GaN) Light Output

BluGlass Ltd., has announced that it has been successful in demonstrating the best ever p-GaN light output using its propriety technology, Remote Plasma Chemical Vapour Deposition (RPCVD) on an MOCVD partial LED structure. This result is greater than a 10 fold improvement in LED efficiency over the first p-GaN demonstration data published by the company in December 2012, when the same measuring methodology is applied. This has been achieved by making significant improvements in addressing the 'interface challenge', a key technical hurdle that has been limiting the p-GaN performance demonstration in the past.

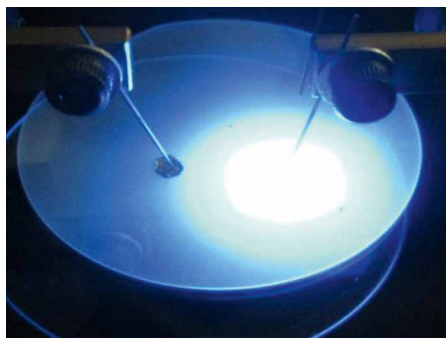

Demonstration of light emission at 473nm, with full width half maximum of 22nm, from a RPCVD p-GaN layer grown on a MOCVD partial structure

These recent breakthroughs are the result of the enhanced plasma system in combination with new process steps which are now yielding continuing performance improvements as the company furthers progress towards its Brighter LEDs milestone.

BluGlass Chief Technology Officer, Dr. Ian Mann said "The RPCVD p-GaN based LED performance in the last month has undergone a step change improvement. This has been achieved by focusing on two key aspects – the process steps for initiating the RPCVD p-GaN growth; and in finalizing the last layers grown by MOCVD – in effect, making sure the RPCVD and MOCVD steps are compatible."

The next generation RPCVD System, the BLG-300, is nearing completion. This system is a significantly larger system than the current R&D workhorse and will effectively double BluGlass' research and development capacity. ■

Osram Opto Shows "3D nano LEDs"

Osram researchers have for the first time succeeded in manufacturing a so-called "3D nano LED" for white light. In contrast to today's standard LEDs, they are not smooth but consist of many adjacent, microscopically small columns with a three-dimensional structure increasing its light-generating area. The new technology is expected to achieve series maturity in coming years.

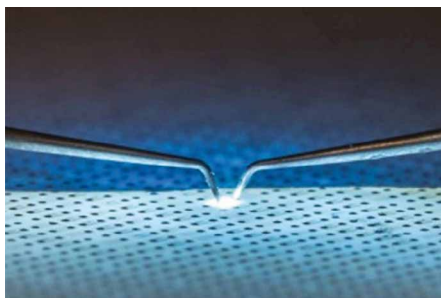

Osram researchers make a 3D nano LED for white light shine on the wafer using two tiny, energized needles which are pressed onto the contact points that correspond approximately to the thickness of three sheets of stacked writing paper

The determining factor for the capacity of an LED chip factory is the wafer size. The quantity of chips per wafer is limited by the fact that a specific LED chip surface is required for a certain quantity of light. The prototype chip has a five to ten times larger surface on the same substrate than current LED chips, and generates significantly more light in relation to the base area. In the future, the luminous efficacy will be increased by approximately 10%.

To achieve the 3-D chip geometry, a particular masking layer is applied to the wafer above the first deposited semiconductor layers which can be imagined as an ultra-thin glass panel covering the chip itself. Holes are then applied to this with diameters of just a few hundred nanometers, through which the characteristic columns of the Nano LED develop. These columns are then coated with a transparent contact material to ensure that the driving current can spread across the entire surface.

The prototype chip is particularly application-oriented because its surface has already been applied with a new type of extremely efficient phosphor material to generate white light. ■

WHAT'S IN YOUR LED FIXTURE?

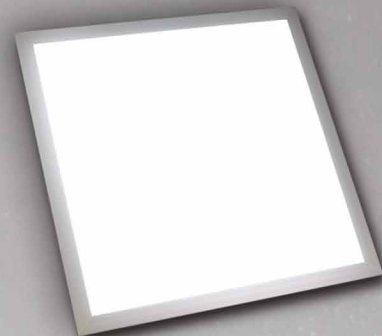

GLT LED light guides provide superior output & uniformity in your custom design.

- Fewer LEDs needed
- Custom sizes and shapes for ceiling, wall, cabinet, task lighting & more
- High volume manufacturing & fast turnaround

Put the power of GLT light guides in your fixture and see what a difference it makes.



Cleveland, USA • Taipei, Taiwan
440-922-4584 • sales@glthome.com
www.glthome.com

See us at **electronica 2014**
Hall A6, Booth 420/2

LED professional Lighting Forum at the electronica 2014

Luger Research e.U., publisher of LED professional and organizer of the LED professional Symposium 2014, will organize the inaugural Lighting Forum as a part of the electronica 2014 on November 13th, 2014.

The International Year of Light (IYL) 2015 will form the core of the forum program. The forum concentrates on lighting technologies and will bring together stakeholders in EU lighting as well as key persons from the IYL 2015 initiative. Prof. Joseph Niemela from the International Centre for Theoretical Physics (ICTP) will open the forum with a keynote presentation, highlighting the main aims and expectations of the IYL 2015 initiative. ICTP is responsible for coordinating the IYL 2015 effort. A subsequent panel discussion, entitled "International Year of Light 2015 – Strategies and Technologies", will include academics involved in LED, solid-state lighting (SSL) and smart lighting research, as well as entrepreneurs and members of the European lighting consortia. The discussion

will focus on the main strategies for lighting in Europe as well as future innovation and technologies that can accelerate Europe's competitiveness on a global scale.

This will be followed by an interactive technical panel discussion on "Trends in Solid-State Lighting" aimed at engineers and researchers. Consisting of CTOs and heads of R&D from leading companies, the discussion will introduce the current innovations and highlight key technical aspects of electronic designs for lighting applications.

The Lighting Forum is a part of the Electronica Forum, which also includes the Security Forum and the Energy Efficiency Forum, a CEO Roundtable on the topic of "Internet of Things" and a Student Day. In addition, an Automotive Forum, an Embedded Forum, a PCB & Components Marketplace as well as an Exhibitor Forum will take place at the electronica 2014. Table 2 provides an overview of the different forums and their main topics. ■

Forum Program Overview - Nov. 11th - 14th, 2014

Forum	Location
Automotive Forum	Hall A6
<ul style="list-style-type: none"> • Multimarket • ISO 26262 • Automotive lighting • Sensor fusion • Connectivity 	
Electronica Forum	Hall A3
<ul style="list-style-type: none"> • CEO roundtable: Internet of things • Sector forums: Lighting, Security, Energy efficiency • Student day 	
Embedded Forum	Hall A6
<ul style="list-style-type: none"> • Micros and DSPs • Smart metering • ARM-based computers and processors • Industrial control and communication • Embedded computing • Energy management and efficiency • Small form factor boards - tools and software • Electronic lighting - software development 	
PCB & Components Marketplace	Hall A2
<ul style="list-style-type: none"> • ZVEI initiatives on supply-chain management and design chain • ZVEI services in EMS initiative • Repairing/reworking electronic assemblies • Market trends for PCBs, hybrid circuits and electronic assemblies • Market outlook for the global electronic industries 	
Exhibitor Forum	Hall B5
<ul style="list-style-type: none"> • Companies introduce themselves and present their latest products, developments and services 	

Lighting Forum Agenda - Nov. 13th, 2014 in Hall A3

10:00 AM - 10:15 AM	Keynote speech by Prof. Joseph Niemela, ICTP, Trieste
10:15 AM - 11:30 AM	Panel Discussion „International Year of Light 2015 - Strategies and Technologies“
11:30 AM - 11:45 AM	Break
11:45 AM - 01:00 PM	Panel Discussion „Trends in SSL Lighting - Electronic Designs for Lighting“

Welcome to Planet e.

The entire universe of electronics at a single location!

Tickets & Registration
www.electronica.de/en/tickets



Messe München
International
Connecting Global Competence

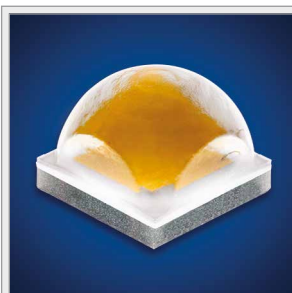

CREE XLAMP® XP-L LED IS THE INDUSTRY'S BRIGHTEST AND MOST EFFICIENT SINGLE-DIE LED

Cree® XLamp® XP-L LEDs are the first commercially available single-die LED to achieve breakthrough efficacy of up to 200 LPW at 350 mA. Delivering up to 1226 lumens in a 3.45 mm x 3.45 mm package, the XP-L LED enables an immediate performance increase of 50 percent or more as a drop-in upgrade for XP-G based lighting designs. As the brightest member of the industry's only family of high-density class discrete LEDs, the XP-L LED redefines performance, cost and size of LED lighting.

Please visit www.cree.com/xlamp/xpl to learn more.

CREE

We bring quality to light.



DISCOVERING
LIGHT

Putting LEDs in the right light.

SSL solutions from the world leader in LED measurement



LGS 1000
Goniophotometer
with new features

Right from the start, we have been supporting the LED industries with our measurement equipment. You will also benefit from this expertise in the new Solid-State Lighting applications. Our solutions combine highly precise spectroradiometers and photometers with a complete family of goniometers and integrating spheres. Discover light with Instrument Systems.

www.instrumentsystems.com/ssl

 **Instrument
Systems**
light measurement

LpS 2014 – Symposium for Integrated LED Lighting System Designs

A new holistic and interactive approach has been incorporated into the LED professional Symposium +Expo 2014 (LpS 2014). Multidisciplinary expert talks, hands on workshops and interactive group discussions will take place in Bregenz, Austria, from September 30th to October 2nd. Attendees will be inspired to create new designs and engineering concepts for future LED lighting systems in order to transform innovations to the next level.

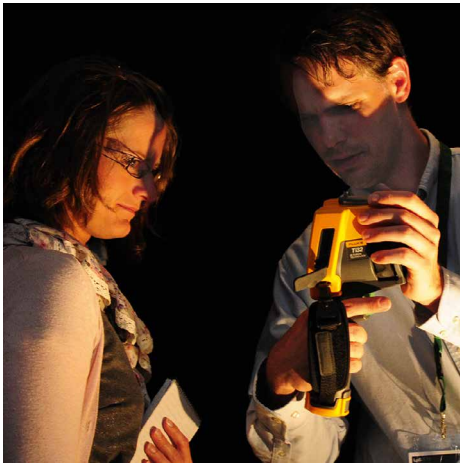

Beside the broad range of lectures on Design & Engineering for future LED lighting systems, the 4th LpS has a strong focus on interactive hands-on workshops

Theory meets Interaction

The first two days of the Symposium will include 58 inspiring lecture presentations about trends and visions for future LED lighting systems, materials and manufacturing, light sources, reliability and lifetime, engineering of LED optics, electronics and smart lighting as well as designs with LEDs and OLEDs. As a highlight of the event, Day One will debut the presentation of the LED professional Scientific Award. After attending the lectures, participants are invited to apply and correlate their knowledge in workshops and tech-panels on the third day. The aim of this day is to foster the exchange between the various industries and academia in order to create integrated system designs. Latest technologies, smart systems, new standards, advanced functionalities and new user behaviors will be analyzed and discussed.

Dr. Mehmet Arik, known as the “Edison of the 21st century”, will open the workshop series

with his keynote about “Breakthrough Technologies and Strategies in SSL Developments – Thermal Management of LEDs”. He has written over 125 papers and four books and holds more than 40 patents. Dr. Arik compares LED lighting systems with smart phones or tablets. “They are advanced systems and require a great team effort. Additionally, we have to make these systems affordable. Chips are already getting cheaper. Compact and low-cost reliable electronics, lightweight and compact thermal management will be key technology drivers for the next decade”.

Workshops and Tech Panels

This year, five workshops will run on parallel tracks. Topics like Visual Perception, Luminary Design, 3-D Printed Optics, LED driver designs for Smart Lighting and Zigbee for wireless lighting solutions will be discussed and demonstrated. Dominic Harris, named as “The Breakthrough Talent of the Year” at the design industry’s FX Design Awards, will be one of the presenters at the 3-D Printed Optics workshop held by LuXeXcel. He was awarded for his work in interactive design from the Bartlett School of Architecture.

LED technology offers new spectral and radiative features for lighting applications where conventional quality criteria and measures are not sufficient enough. At the same time knowledge about light impacts on human and human needs has increased significantly over the last two decades. The workshop “Visual Perception” deals with the most important features regarding visual and non-visual perception which has to be respected for LED applications, including spectral quality, color mixing, light directness and shadowiness as well as flicker and color shades. Bartenbach Research and Development will hold this workshop.

The lighting industry is facing a shift from wired towards wireless connectivity, driven by several trends. The way people control devices is changing. New value added functionalities in automation are becoming more common and enhancing the customer’s experiences. Additionally, wireless technology is now available at low prices. Consequently a unified approach is required to enable system compatibility. Therefore the Connected

Lighting Alliance (TCLA) has defined the ZigBee Light Link standard as the preferred common open standard for wireless controlled lighting, which will be introduced and discussed in detail at their workshop. NXP, Philipps, Lutron and the ZigBee Alliance will explain how to implement this standard.

Parallel to the five workshops there will be two open Tech-Panels. The first one is more general and will be about strategies and technologies for LED systems, related to the aims of the International Year of Light (IYL). Prof. Reine Karlsson, Director Lund Lighting Initiative at the TEM Foundation at Lund University, Dietmar Zembrot, President of Lighting Europe, Carlos Lee, Director General at EPIC and Henk Veldhuis, Chair of the Technical Advisory Working Group of The Connected Lighting Alliance, are taking part as panelists. The second Tech-Panel is more technical and deals with design and engineering for future LED lighting systems. The panelists in this discussion are Dr. Martin Zachau, head of Osram’s research organization, Dr. Kevin Smet, Research Foundation Flanders, Dr. Mehmet Arik, Ozyegin University, Turkey and Dr. Norman Bardsley, President of Bardsley Consulting.

International Exhibition and Partners

Around 100 world-renowned exhibitors, such as Samsung, Cree, Infineon, Wago, Fischer, Bayer MaterialScience, Arrow and OEC will present their latest technologies, products and services. The event is sponsored by UL, Auer Lighting, Tridonic and Osram. Over 20 international media partners, 5 scientific partners and 9 industrial organizations are supporting the event. ■

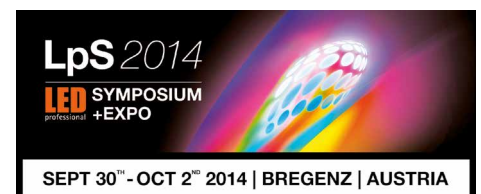

“I think this is one of the most important lighting events in the world”, said Dietmar Zembrot, President of LightingEurope

Weblinks:

LpS Website: www.LpS2014.com

LpS Program: www.LpS2014.com/program

Registration: www.LpS2014.com/registration



TAKE ADVANTAGE OF OUR LIMITED-TIME PROMOTIONS

For a limited-time* UL is offering special promotions for Performance Testing on LED Modules and LED Luminaires.

VISIT UL AT LPS - **STAND A12**

www.ul.com/lighting

UL and the UL logo are trademarks of UL LLC © 2014

*The offer is only valid prior to 30 November 2014. Other terms and conditions may apply. See a UL associate for additional details.



Tech-Talks BREGENZ - Dietmar Zembrot LightingEurope, President



Dietmar Zembrot

Dietmar Zembrot is currently President of LightingEurope. He also serves as Vice President Division Lighting of ZVEI. Since November 2008 he has also held the position of Managing Director of the TRILUX Group. He is responsible for technologies, product development and supply chain. He previously worked for the Zumtobel Group in various positions and European locations, accumulating over 20 years of experience in the lighting industry.

Rapidly growing technologies and emerging market trends in solid-state lighting encourage new innovations largely driven by applications and technological developments. Dietmar Zembrot, President of LightingEurope and Managing Director of TRILUX Group, shared his insights on changing value chains and business models, Europe's competitiveness and the main driving forces for current SSL technologies.

LED professional: LightingEurope is a new consortium. Could you tell us about its creation and the main aims and goals?

Dietmar Zembrot: In the past we had two organizations working on a European level in the lighting business: the European Lamp Companies Federation (ELC) and CELMA, the organization of all national lighting associations. This was disadvantageous because we didn't have one voice in Brussels. The first target was to create a new association consisting of both association and company members, with the aim of having one unified voice in Europe. The second target was to tackle this field as one organization because the value chain is changing and you cannot distinguish between lamps and luminaires. We have also worked together in the past, but now it is more obvious that we need to be united to deal with specific tasks, e.g. the strategy paper on lighting in Europe. The goal is also to communicate the benefits, be it in technology, energy savings, light for life or what we can do for the elderly. Europe has and should have very specific activities in these areas. We are also trying to support other interests at the market level; e.g., the rules for European and global competition should be fair. We are also connected to the Global Lighting Association (GLA) and other associations, making sure that there is one focus. The Vice President of LightingEurope is also the president of the GLA. In Germany, ZVEI is a member so I represent ZVEI on the executive board and there is an association committee that is working to ensure that what is said is consistent with how we follow up nationally. There are a lot of opinions in an area that is disruptive and it is not always easy to find a common one.

LED professional: Does LightingEurope also have an advisory role or an influence in the H2020 trends and directions of the European Commission?

Dietmar Zembrot: We are working with the Commission to bring in topics in that area. We have handed over a strategy paper from the lighting industry to President Barroso. We are trying to point out what we think will be interesting research programs to help shape the future lighting business. For example, SSL-erate is a program to make stakeholders aware. They see LED as a future trend and they see Europe playing a role there.

LED professional: The Green Paper on SSL technologies stated that the EU is lagging behind its global counterparts. As the CEO of a major lighting company how do you see the current global lighting situation and Europe's place in it?

Dietmar Zembrot: I think we need to be careful about saying that 'Europe is lagging behind'. What does that really mean? Are we competitive in lighting? Yes we are. It has always been a regional business and the fittings we have in Europe for this market are comparable with American or Asian fittings for their markets. Secondly, if we look at the lamps business, where sometimes the light emitting part is now replaced, from a halogen, incandescent or high/low pressure lamp, with an LED, there has definitely been more focus on European production. Looking at European headquartered companies, I don't see a major disadvantage in their global competitiveness provided you compare the right things.

In the past the lighting market was led by Europe because the Asian markets weren't developed enough and there was no need for the Americans to invest in T5 technology like Europe did. That has just leap-frogged and they have initially pushed the market forward to the LED market. What happened, and this is a big change in Asia and the USA, is that there are huge programs to support this new technology. Whereas, even though there are programs in the EU and we are satisfied with what has been done, there is room for more compared to these regions and compared to the past.

LED professional: You talked about working with various stakeholders and how a common voice is not always easy to find. Is that because there are so many different kinds of stakeholders? What are the roadblocks to finding a common voice and how could this be solved?

Dietmar Zembrot: This is a complex question. I think, as the technology is not evolving but disruptive, it is difficult to have a common view for the future. As always, changing technology also influences change in value chains and business models. You can see that quite clearly in the past year in Germany. While the market was growing at about 3%, the professional indoor luminaire market was growing more than 10%; the outdoor market was growing nearly 20%, which was an impact of the founding program we had there; and components were shrinking by about 10%. If you look at lamp holders it was an even higher figure, meaning the value chain is changing. In that respect companies need to change but we don't have experience. Some predictions were not right or were understated; for example,

The “Festspielhaus” Bregenz with its impressive stage was the perfect setting for the expert discussion. The picture shows Dietmar Zembrot talking with Amrita Prasad



the transformation rate - different parts of the lighting industry are transforming faster than others. Emergency lighting is already close to 100%; outdoor lighting has a LED rate of 60% while common recessed fittings may be below 10%. Depending on where you are in the business you might have a different view. And this makes it more complicated. In the past we had time to react, think about and evaluate the different opinions, but today decision-making processes have to be fast.

LED professional: Value chains and business models are changing. The component business is declining whereas the system side is growing. Can you give us figures for systems transformed into SSL?

Dietmar Zembrot: That would be extremely difficult because we are used to evaluating current turnover. LightingEurope is also working on an EU statistic which is not yet ready. I would say that in the more leading markets, like Germany, you can expect to have an LED ratio of around 35% on the installation side of newly installed business.

LED professional: What about an overall figure?

Dietmar Zembrot: It is very difficult to give a general statement because we have never compared our new installation business to the existing luminaires. It is definitely below 10%. We need to be extremely careful because market growth doesn't necessarily mean growth in every field and it doesn't necessarily mean volumes. This 35% on luminaires probably translates to something like 25% in actual numbers. This is a lower figure because investments for LED fittings are higher. So this should be compared at an individual business or lamp source level.

LED professional: You also said that there are different kinds of applications and target groups for selling luminaires. The 'residential' group is still lagging behind because a lot of luminaires are still built the conventional way using retrofit lamps. Is that the right way to go or are these, often, smaller luminaire manufacturers that don't have resources for research?

Dietmar Zembrot: I think the total industry is struggling with the effect that this light source is developing and the benefits, especially the financial ones, are only with time. We are a very investment driven business and not 'total cost of ownership' business. Secondly, lighting can do much more than was ever possible! If you talk about residential and consider something like the system, which is programmable and controllable via Internet, the complexity is changing compared to an incandescent lamp. So what we see is that there is a fast LED transition rate but due to the structure of the companies, a lot of retrofit lamps are still used. The complexity of developments and investments for new luminaires are higher due to more complex technology. If volumes are low this can also be an issue. But in the end, the consumer has to take a decision.

LED professional: We are already at a high efficacy level with LEDs and it is becoming more and more difficult to gain additional relevant savings. Of course it depends on systems but we may reach 240-250 lumens/Watt

system efficiency before we hit physical limits. It is relevant for energy savings but from a monetary point of view it doesn't seem to make a big difference. How do you see this in the future?

Dietmar Zembrot: The effect of light on human beings is under-valued in domestic areas. Investments in sanitary facilities or kitchens are much higher than lighting in homes. Maybe it is a lack of awareness or willingness. I am sure we will see some changes there. It is not just about energy efficiency, it is also about the other effects of lighting, which we have to make common knowledge. Finally, the most efficient systems on the market are close to 150 lumen/Watt, which is nearly double what they were in the past. Looking at the cost for the customer, you also get the benefits of industrialization. This means higher volumes will create a better price in every component but also in the fittings. Customer use is still rapidly growing, not just from an efficiency and investment point of view, but also aesthetics, light quality and other features of luminaires. One of the favorites is street lighting. Most light sources weren't controllable in the past and now LEDs are a fully controllable light source and can be combined with a lot more intelligence. Currently we see a huge demand for outdoor controlled lighting systems, which will enable new energy savings. If you combine lighting control, fitting sizes and direction of light. There are much more than pure energy efficiency considerations for the source and much more that we can do with these light sources.

LED professional: So you agree that it is still most often a question of system efficacy and efficiency and the future has to focus more on the opportunities that we have with this new light source than on the efficacy gains?

Dietmar Zembrot: I couldn't have said it better myself!

LED professional: You also mentioned about understanding the effects of lighting on people. How would you define human centric lighting and smart lighting?

Dietmar Zembrot: I think this is an overlapping field. For human centric lighting you probably need smart fittings or smart electronics and control. We are also driving this with ZVEI. LightingEurope is preparing market research in this field with external funding. We are also funding certain research areas. The biological effect of Human Centric Lighting is a huge field. Dimming, color and aesthetic effects are comforting so whenever a fitting reacts to the user's needs, I would say it is human centric. Biologically, there are huge strides that could be made in elderly homes or in hospitals. It is an effect that is sometimes questioned. Some people might say 'I don't want my children to be influenced by lighting at school' but people are always influenced by their environment.

LED professional: What about Smart Lighting?

Dietmar Zembrot: Smart lighting for me, is more on the technical side and I definitely need smart solutions for what I described earlier. But it goes beyond that because smart lighting doesn't necessarily need to target human beings. For example, if you control peak needs in companies or if we combine traffic control with luminaires there are several possibilities to make lights smart and reactive or even to overcome the effect of people not switching off installations. So 'smart' is everything where I react with the environment on a human side but it could also be purely technological.

30+ years CEM turnkey provider at your service for LED/O-LED/SSL feature-rich applications:

- Hi-Density Arrays of mono/RGB modules
 - Ultra Miniature $h < 1 \text{ mm}$
 - High Power $> 10\text{W}/\text{mm}^2$
- R&D, Industrialization, Manufacturing

Explore all opportunities in lighting & signage!

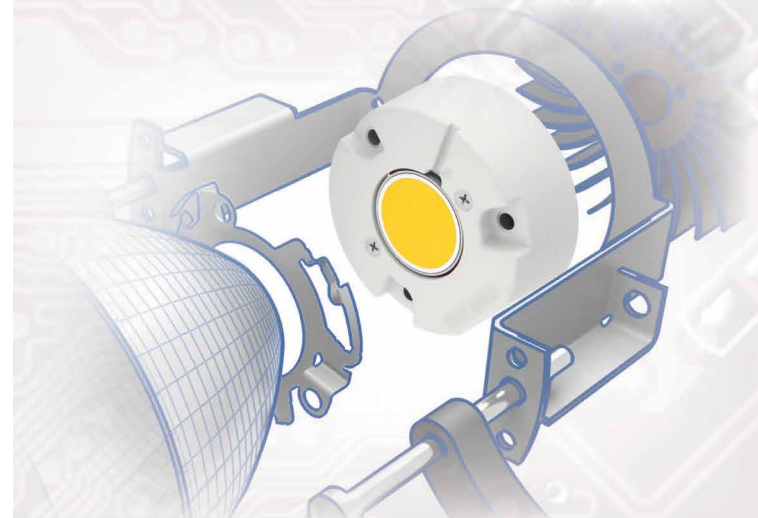

Please call us to discuss your LED requirements

Design Skills - Product Development Service

Full electronics, mechanics, software development

MOEMS Engineering and Production

Micro-Optical-Electro-Mechanical-Systems department with ISO Class 7 clean room

New Product Introduction and Manufacturing Services

Product Qualification, SMT assembly lines, BGA/FPGA/COB/COG box build assembly seamless cross-site transfer for convenient and scalable mass-production

ESCATEC brings world-class design, manufacturing services and MOEMS technology close to you!

ESCATEC Sdn Bhd, Office in Switzerland:

Heinrich-Wild Strasse 9435 Heerbrugg

Tel. +41 71 727 3941

Email: ESCA-LED@escatec.com

LED lighting is more than just efficient lighting. Color tunable modules in combination with smart controls allows for the adaption of light to fit human needs exactly; be it in workplaces, in care homes or residential dwellings. LEDs really allow for human centric lighting-lighting

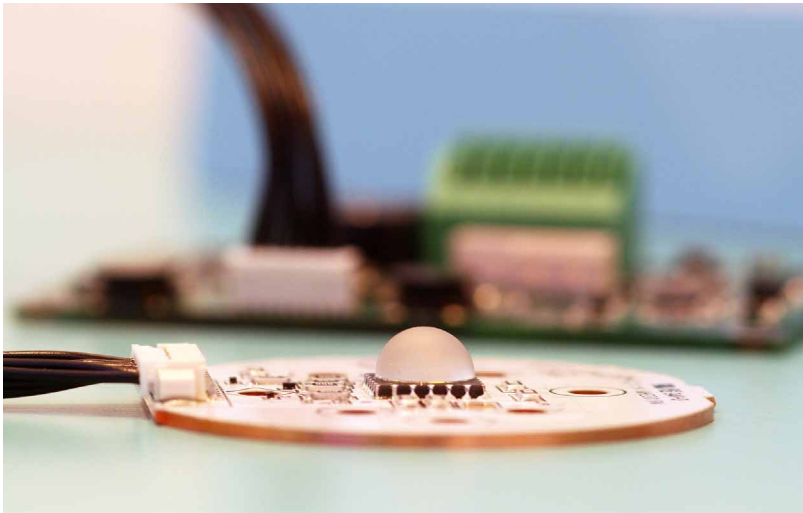

LED professional: Could you comment on the outcomes of the ATKearney market study (Human Centric Lighting: Going Beyond Energy Efficiency), particularly on the estimated revenue expected with Human Centric Lighting?

Dietmar Zembrot: In principle, in 2020 it could be one third of the high-end lighting business. So it is a significant portion, which is strongly related to information and the political environment. Coming from the lighting business and knowing the positive effects for ageing diseases, we could think about being more regulative in seniors' homes. On one hand this influences the thought processes of people and also strongly influences the people who care for the elderly. How the stakeholders are informed is important as well as the question of if the government will really help Europe to implement by funding research and technology programs. If the next research programs and funding in Germany could switch to intelligent lighting, it would help us to develop and invest in the technologies faster.

LED professional: We have discussed a lot of requirements and each of these needs additional changes or research in the technology field like the influence of lighting in elderly homes. Are we ready with the technology? What else needs to be developed to really fulfill these requirements?

Dietmar Zembrot: I would say we are ready from the research and technology points of view,

to implement a strong change on the use of lighting. However, all options are not fully explored and we have not reached the end of this road yet. We could do much more with controlled lighting systems or energy efficient light sources. We have not really explored what could be done for the future. Every day we have a new surprise and find better solutions. The customers will determine what else has to be done. The challenges are out there, competition is strong enough in Europe and globally and I think all of us in the lighting industry are standing up fighting every day to cope with the speed and to move forward.

LED professional: With regards to standardization, on the one hand there is a push towards it. Is this an efficient way to move forward and is it even possible to have global standardization?

Dietmar Zembrot: I think there are definitely areas where, for example, Zhaga has made its way but in my opinion we will not have such a highly standardized business as in the past. The lamp, for example, was standardized. Now we have rapidly growing new opportunities and we're growing new form factors in fittings or other solutions like human centric lighting. It is impossible to provide all these solutions with standards.. Therefore, the field will be more open and I predict that currently technological development is faster than the development of standards. It is hard to predict the final outcome but I think there is opportunity for both.

LED professional: Could you comment on wireless vs. wired and the trends that are going in that direction?

Dietmar Zembrot: This is based on regions. For Europe, we have to clearly state that the trend is towards renovation and not towards 'new build'. Wireless does have an advantage in renovating installations. We also see that a lot of people are getting used to control with wireless devices. So this might also push it in that direction. On the other hand, you also have power over IP, which is strongly supported in the US. I would say there will be more diversity than in the past.

LED professional: Suppose industries such as Trilux have to support standardized solutions. Will there be more variety in the end?

Dietmar Zembrot: When there is a standard available that we think fulfills the customer need and we can hardly do better, as a company why should we try to develop something just for the sake of being different? Technology is moving fast so we can think about better lighting or electric control. If we think we can fulfill a customer need better than a standard, that will drive us to non-standard solutions. You don't want to wait but want to be the first. It is not about the big and the small but more about the fast and the slow! And it is not just us who discovers new things; it is also customers who discover new applications. Yet there are a lot of people who make something like wireless controlled domestic lighting systems with even a programmable interface but the young people will see that completely differently and use light in completely different ways.

LED professional: Would you say that in the past the lighting designer was limited with restricted opportunities? With the great flexibility that LED systems can offer, are they now bringing back new requirements?

Dietmar Zembrot: In the past a very simple thing like having a homogeneous round lit surface was a challenge. It is no longer so. Instead we are asking how to direct light and what could the

different building factors be and what is the right resolution. In the past, next steps like changing light colors or light directions were linked with huge investments and larger sizes. The investments and sizes needed today are not comparable to what we had in the past. And as we can create customer benefits with less investment, the lighting designers will grab these opportunities as they are close to the end users.

LED professional: It is said that many LED luminaires are not good enough in CRI and the distance or difference in MacAdam's ellipses from one light source to the next is under discussion. The same goes for fluorescent lamps. Do people expect LEDs to be better?

Dietmar Zembrot: The discussions that we heard especially at the beginning of this technology were about color rendering, the artifacts on lenses, and color shifts depending on beam angles. But technology is moving very fast and I would say if we look at the first marketable LED fittings compared with what we have now, having been in this business a long time, I have never seen such huge steps! The fittings we launched 4 years ago at a light fair in Frankfurt and those we have now are not comparable in terms of light quality, CRI or the way light is directed. We now have solutions where we don't even see the light source anymore and have soft light distribution in a room. We can go 20 centimeters below the ceiling without a hotspot above the fitting - this was not possible in the past. The opportunities are huge!

LED professional: Structures within companies and industry, like the value chains, are changing and a lot of areas that were segregated earlier are becoming more integrated. Is it challenging to bring in changes?

Dietmar Zembrot: I think there are more drivers than the end user. There is energy efficiency and there should also be political, social and ecological responsibility driving us. No processes will be the same as 5 or 10 years ago. Independent to research, purchasing or production, we will have other technology, other machines, logistics - everything has to be changed and adapted to that new technology. There will also be new business models. Financing of light, leasing etc. will once again drive and change us. We're either a part of this business model or we are out. Companies have to change completely. 'Experience' is a word which you like more the older you get, but I have to also say that a lot of my experience can be discarded because now there are possibilities which weren't there in the past.

LED professional: From an engineering point of view, on a system level, we have optics, electronics, light engines with LEDs, thermal management etc. Which engineering area needs the most work or lacks information?

Dietmar Zembrot: The biggest change is to think from an individual task towards creating a system. 'I make an optic' to 'we create a system' is the biggest change and one influences the other. Thermal requirements are more sophisticated than ever. We are creating more knowledge with every building, structure, size or design. The LED itself tells you nothing. If you have one that is 10-20% less efficient, it could still be the better solution in a system.

LED professional: How do you see fully integrated systems using microelectronics or semiconductor knowledge from the control, drivers and sensors side? Will lighting finally be a fully integrated 'computer' where it is all controlled with software?

Your Partner for thermal solutions



Nadlerstraße 8 - 10
88299 Leutkirch
Germany
Tel.: +49 (0) 7561 9837 0
Email: info@ekl-ag.de
Website: www.ekl-ag.de

EKL[®]
electronics cooling

It is certain that OLEDs will find their way into general lighting applications, especially in those situations where LEDs cannot satisfy requirements. Another area will be special applications like these transparent OLEDs that emit 90% of the produced light in one direction



Dietmar Zembrot: The entry barriers for lighting as a whole have changed. In the past, the lamp was quite a complex entity and the control required a close interlink with the lamp. You needed a new competence for the fitting. The control and operation of an LED is much easier now than a high-pressure or low-pressure lamp. In the end it always comes back to customer needs and how to best meet them. In the past it was either a non-lit outdoor façade or we lit up a building from a point. Now we can very deliberately light from points far away or very close because sizes are small. We can control the light and make it change. So I would not say that there is a 'one size fits all' solution. Once again, the more aware the

people are of what we can do, the more diversified the applications. This will require different solutions and building blocks.

LED professional: You said you don't see just one light source, which brings us to the OLED. Currently it seems like a niche product but what about the future?

Dietmar Zembrot: OLEDs are predicted to leave niche production and have an impact on the lighting industry. I could imagine that there are requirements that are not easy to fulfill with LEDs, like 3-D structures. The question is also about performance and price compared to LED solutions. LED also started with

backlit TVs, automotive areas etc. so the automatization and industrialization of OLEDs is moving forward and the more benefits this technology has, the more it will be used. The studies are saying that between 2016 and 2018 there will be a significant impact in general lighting. Honestly speaking, my first experience with LED luminaires was 16 years ago. I would say that in the last couple of years this has really exploded and the turnover is already 40% in some markets. But the uptake was more in the last few years and not linearly for the last 15 years. OLEDs are not a big player in the general lighting market at the moment but there are very interesting fittings out there for some niches. There are very different opinions from market research but in my opinion it is not a disruptive but an additional light source to the LEDs, especially for special applications.

LED professional: You will be a panelist at LpS 2014 in Bregenz in the discussion 'International Year of Light (IYL) 2015 – Strategies and Technologies'. What are your expectations from the IYL initiative and are there any events or any initiatives planned at an industry level or by LightingEurope?

Dietmar Zembrot: I think the IYL is a good thing because we are getting some awareness on lighting. Through the LED trends we have much more focus on the subject now than in the past. I expect that the IYL will drive that further not only from a customer point of view, but also from the view of young people and researchers having more interest in making changes to this business. This is the expectation we have and we are following up closely to see where we can position ourselves as LightingEurope or as the German association or as an individual company. There will be events where we will participate but the expectations are that we get more awareness, more interest and, in the end, better technology solutions. I am quite sure that this will happen having experienced some other successful actions taken on a European level. ■

LpS 2014

LED SYMPOSIUM
professional +EXPO

"I think, this is one of the most important lighting events in the world."

Dietmar Zembrot, President of LightingEurope

4th INTERNATIONAL

LED professional Symposium +Expo

LED & OLED Lighting Technologies

SEPT 30TH - OCT 2ND 2014 | BREGENZ | AUSTRIA

LED & OLED Light Sources | Light Engines & Modules | Optics Driver ICs & Modules | Thermal Management | Substrates & Mounting Technologies | Production & Testing Technologies | Reliability & Lifetime | Color Consistency | Standardization
Smart Lighting | Wireless Controls | Human Centric Lighting | Market & Technology Trends | Scientific Awards

www.lps2014.com



TRIDONIC
enlightening your ideas



OSRAM
Opto Semiconductors

High Color-Rendering, Full-Visible-Spectrum LEDs

The first wave of conventional white LEDs primarily focused on lumens per Watt. These LEDs were based on phosphor down-conversion using primary blue “pump” emission. Currently LEDs are catching up in regards to light quality using different approaches. David Aurelien, Senior Principal Scientist and Mike Krames, Chief Technology Officer at Soraa explain their technology approach of violet-pumped, full-visible-spectrum LEDs, and the interrelated challenges and advantages.

The original promise of solid-state lighting is a positive return on investment of higher prices for lighting products in exchange for even greater savings from reduced energy consumption. Indeed, assuming 80% energy savings (achieved today vs. incandescent or halogen by many LED retrofit lamps), a 50 Watt equivalent solution for a 12-hour-per-day application can command a \$25 price and still pay back in about one year. What does “equivalent” mean? In general, it means a product that puts out about the same number of lumens as the product it is intended to replace. Why lumens? Because this is the industry standard metric which drives how bright a light source appears to the human eye, for example, if you were staring into it.

The supremacy of the lumen, and derivative cost metrics such as lumen-per-Watt (energy) and lumen-per-dollar (product), as the driving metric for solid-state lighting has significant ramifications. In particular, it drives the design of the light source light, itself, towards maximizing luminosity at the expense of everything else. This is achieved by engineering the light source emission spectra

to maximize the number of (human eye) cone receptors responding to the incident light. This means the light source should produce the preponderance of its emission in the green-yellow regime wherein both medium (M) and long (L) wavelength sensitive cones are excited, and as little blue as possible (and necessary) to achieve a white color balance.

The Challenge

The LED industry, driven to supplant conventional lighting products with its superior technology at the fastest possible pace, developed white lighting products based on primary blue-emitting LEDs (the lowest photon energy possible to still produce white light) exciting green/yellow phosphors to maximize spectral luminosity. Standards such as Energy Star further fueled the lumen-based mind set, setting respectable lumen per Watt targets but only mediocre requirements regarding color perception (minimum color rendering index Ra of 80, and minimum deep-red index R9 of 0). The result today is a ubiquity of LED-based lighting products with broken emission spectra: No violet light, a cyan “gap” (between the primary LED and first phosphor emission), and a lack of red, as shown in figure 1.

What the lumen-based metrics do not take into account is that visual experience for the end user is not governed by light that goes directly from the light source into the eye, but rather by light that is reflected off objects in the environment under consideration. Indeed, the human eye has evolved to adjust to brightness levels and the iris will constrict or dilate to achieve a comfortable level of light detection. However, there is no such adjustment for color perception. If the signal is not there, it will simply not be detected. This is especially important in the red color regimes (also relevant for human skin), since the M and L wavelength cone responses are strongly overlapping (in some cases so much as to cause red/green color blindness), and while a light source with a substantial lack of red emission may still appear white, objects illuminated by it will reveal its shortcoming in the form of washed-out colors, unnatural pallor of skin, etc. Indeed, one could argue that a lumen-based approach to light source design is antithetical to that which one would pursue for good illumination. For the former, one wants to maximize yellow/green emission and minimize red. For the latter, one should target a wide emission spectrum with substantial light in the deep red, and reasonable emission in the blue (and even shorter wavelengths, as will be discussed later).

Figure 1: Spectrum comparison of standard blue-based LEDs to incandescence (2700 K) and daylight (6000 K)

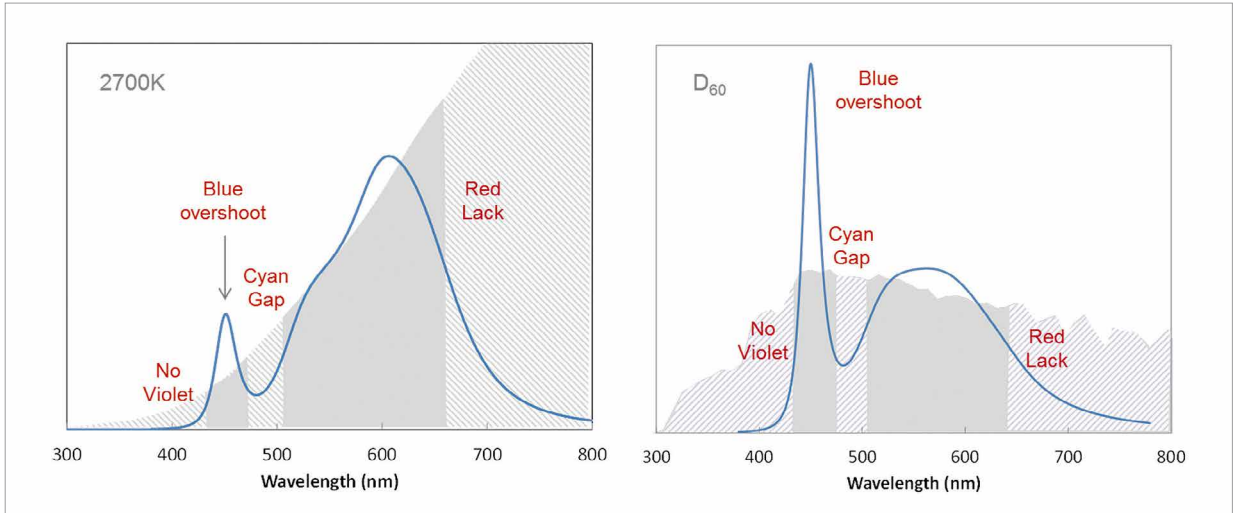
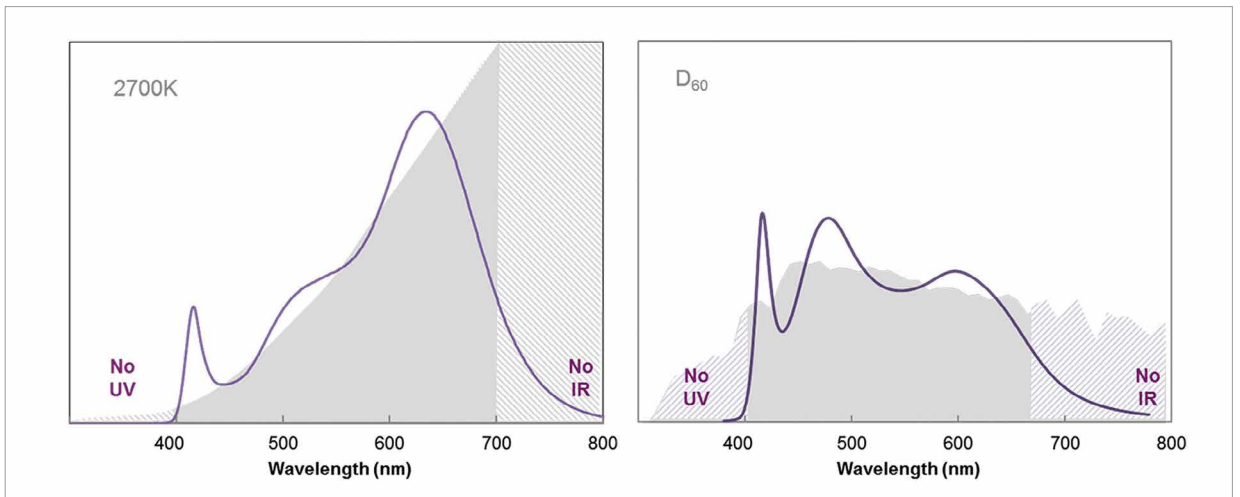

Figure 2: Spectrum comparison of full-visible-spectrum LEDs to incandescence (2700 K) and daylight (6000 K)



Full Visible Spectra

There is really no mystery around what should be reasonable targets for full visible spectrum emission: Nature and evolution show us the way. Sun and sky light vary dramatically throughout the day but are consistently broadband including (by definition!) all colors in the rainbow. Incandescence including firelight is characterized by smooth broadband sources weighted primarily towards the red. Rendering these sources properly with any light source requires emission throughout the 400-700 nm visible spectrum. This is possible with LEDs, provided the basis is violet (rather than blue) primary emission. Using a violet primary, the bulk of the visible spectrum emission can be provided by broadband phosphors. Indeed, using a combination of blue-, green-, and red-emitting phosphors, a violet-based white LED can produce an excellent match to both

daylight and blackbody reference illuminants throughout the visible spectrum, as shown in figure 2.

By using the right combination of violet primary and phosphor emission, the gap between the LED and blue phosphor can be minimized, as well as any blue overshoot, the cyan regime is filled out, and the red emission is designed to provide high red color discrimination according to product design. Indeed, lighting products from 2700 K to 5000 K have been designed using this approach, achieving Ra and R9 values of 95 simultaneously. The question arises: Are these improvements in light quality measurable for the end user?

Colors and Whites

As already mentioned, our experience of the quality of a light source comes from its interaction with the objects we

observe. Perhaps the best-known manifestation of this interaction is the rendering of colors, typically captured by Ra and by the additional deep-red rendering metric R9. These metrics have been known for decades; however their practical implication is not always well understood. For instance, it is frequently believed that values of (Ra=80, R9=0) are 'good enough' for general illumination. Some assert that better values should be restricted to niche high-end application and question whether they would even be noticed in common use.

However, psychophysical studies conclude otherwise. In such a study, performed by the team of Prof. Houser at Penn State University [1], subjects were asked to compare a typical retail scene illuminated by two lamps: A standard LED lamp (Ra=80, R9=0, blue pump dies) and a high color rendering full-spectrum LED lamp

Figure 3: Human preference for full-visible-spectrum (FVS) LEDs compared to standard blue-based LEDs (center). Corresponding color icons illustrating color gamut and distortion (left and right)

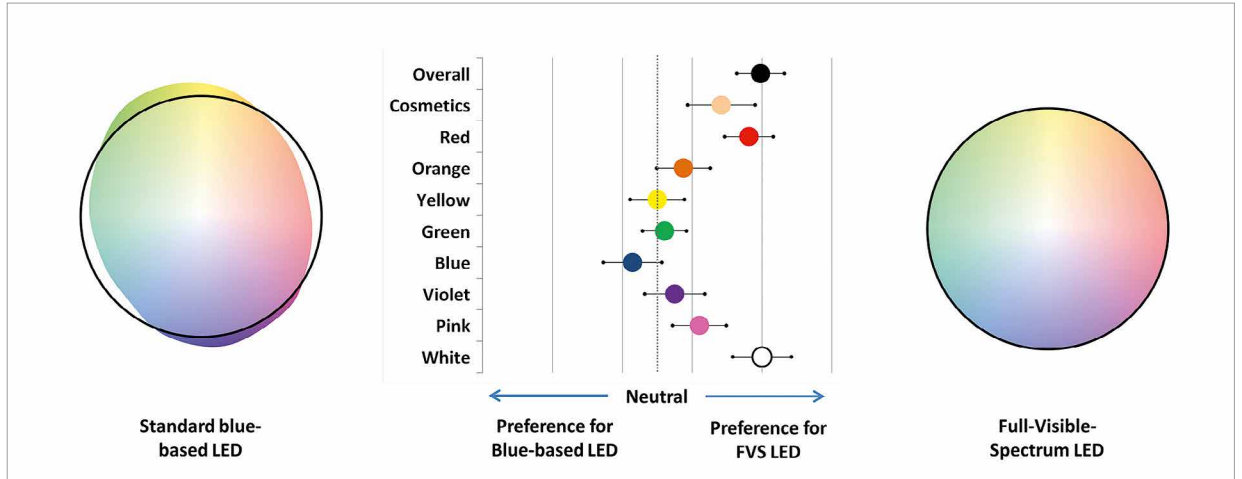

(Ra=95, R9=95, violet pump dies). The subjects expressed a significant preference for the latter – both in terms of overall judgment, and for various specific colors (Figure 3). In particular, there was a strong preference for warm colors (red, orange, pink, purple) which play an important role in our perception. Figure 3 also shows “color icons” which illustrates the color distortion caused by both lamps; they indicate that warm colors are made duller by the standard LED, in good agreement with the experimental results. Thus, the importance of high color rendering to the end user is clearly revealed.

Interestingly however, well-known color rendition metrics do not tell the whole story when it comes to our visual perception. Indeed, they neglect another important question: The rendering of white objects. It may sound surprising that rendering whites should be an issue. Yet we commonly encounter a variety of white materials ranging from muted, creamy whites (such as the porcelain of a plate) to neutral whites (such as painted walls) to very bright white tones (white fabrics, papers, plastics, etc.). Bright whites are obtained by the addition of Fluorescent Whitening Agents (FWAs) to white objects;

FWAs absorb short-wavelength (ultra-violet and violet) light and emit blue light, thus creating a “whiter-than-white” effect. They are widely used by manufacturers to achieve high levels of whiteness.

However, FWAs can only function if they are properly excited by a light source. This is not an issue with natural sources (sunlight, filament lamps) which all emit enough short-wavelength light; even fluorescent lamps provide some amount of FWA excitation. In contrast, conventional LEDs hardly emit any light below 430 nm: Therefore FWAs are not excited, and no whiteness enhancement is obtained. This creates an environment where all shades of whites are rendered with the same yellowish tint. This issue is not captured by Ra or other conventional color rendition metrics, although it corresponds to a very large color distortion for shades of white. Here again, full-visible-spectrum LEDs provide a solution: They emit no harmful ultra-violet light, but enough violet light to properly excite FWAs and render whites like natural sources.

Figure 4: (a) Photographs showing the effect of fluorescent whitening agents (FWAs). (b) Whiteness standard tiles with varying levels of FWA content. (c) Results of sorting tests of whiteness tiles. Left column in under standard blue-based LED illumination; right column is under FVS LED illumination

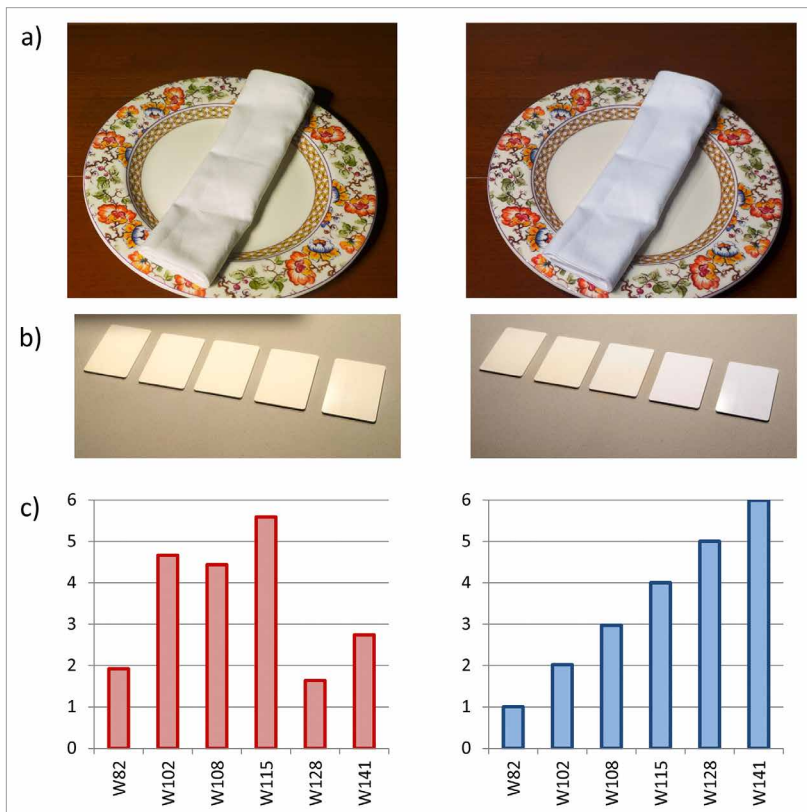

Figure 4a illustrates the issue of whiteness rendering. A scene comprising two white objects (a porcelain plate with a soft white tone and a bright white napkin) is illuminated by a conventional LED and a full-visible-spectrum LED. The napkin contains large amount of FWAs which should make it look bright and clean, standing out against the backdrop of the plate. Under illumination by

standard LEDs both objects have the same dull off-white color, whereas Full Visible Spectrum illumination properly renders the contrast in shades of white.

Is whiteness rendering strong enough to affect our perception significantly? This question was answered by another psychophysical study at Penn State University [2]. Participants were shown a series of white standards (Figure 4b) with varying amounts of FWAs – representative of the shades of white found in everyday life – and were asked to rank them from least to most white. Under a conventional LED illumination this resulted in a disordered ranking as all cards appeared similar, while under full-visible-spectrum illumination the ranking followed the intended whiteness of the cards, confirming their proper rendering (Figure 4c).

The ability to render whites accurately is important from an application standpoint, because it has a strong impact in terms of user preference: When looking at a white dress shirt, participants express a significant preference for full-visible-spectrum illumination (Figure 3).

Therefore, a combined proper rendering of whites and colors contributes to a better user experience which is crucial for the widespread adoption of LEDs. It is worth noting that the experimental response to both colors and whites is very pronounced, thus dispelling the notion that an improvement in color rendition is superfluous or difficult to perceive.

Technology Approach

It is instructive to consider the “penalties” for delivering the full visible spectrum solutions as described above; it does not come for free. First, violet primary emission requires delivery primary 3.0 electron-Volt photons, compared to 2.7 electron-Volt blue photons, a relative 10% increase in required energy. For good color rendering, deep red emission is required, reducing the spectral luminosity by about 20-25% in going from a Ra/R9 of 80/0 to 95/95. Finally, a blue phosphor is required, which although not fundamentally lossy (on a photon basis) does decrease efficiency somewhat since materials are never perfect. The total penalty, again on a lumen basis, is more than 30%. Conventional LED technology

cannot absorb such a penalty and still be viable, efficiency wise. Instead, to overcome such a gap, a very high performing base LED technology is required. This has been achieved, and demonstrated, with the advent of gallium-nitride-on-gallium-nitride (GaN-on-GaN) technology.

Gallium-nitride, or GaN, is the wide bandgap semiconductor that is driving the LED industry. Unlike more conventional semiconductors such as silicon or gallium-arsenide, GaN cannot be grown from the melt, and so GaN substrates have not been available until very recently. This is important because the semi-conducting properties, critical for optoelectronic devices like LEDs, are only revealed in pure crystalline material. This requires that semiconductor material be deposited epitaxially in such a way as to maintain this homogeneous crystalline structure. A starting reference point is required, which for most semiconductors is the native substrate itself (e.g., silicon for silicon-based CMOS, gallium-arsenide for GaAs-based telecommunication devices, etc.). If there is no registration, materials will deposit amorphously, losing their crystalline structure, along with the desired optoelectronic properties.

Breakthroughs in Japan in the late 1980s [3] led to a technique for depositing single-crystal GaN on commercially available sapphire substrates. Similar approaches have been successfully applied to other substrates such as silicon and silicon-carbide. These approaches ushered in the first era of LEDs for solid-state lighting applications, and the vast majority of LEDs today are based on it. While the performance is reasonably good on a lumen basis, there are limitations in performance.

Figure 5 illustrates the situation. GaN epitaxially deposited on a foreign material (top), even using best tricks in the industry, result in defective material. The defect density is typically a few per square micron, or a few million defects in a typical LED chip (1 mm x 1 mm), and is readily viewable in cross section transmission electron microscopy. While not prohibitive with regards to performance, this level of defect density does limit the range of efficient light generation from a wavelength perspective, as well as limit the operating power density. Indeed,



AQUALUC[®]
BRAVING ALL ELEMENTS

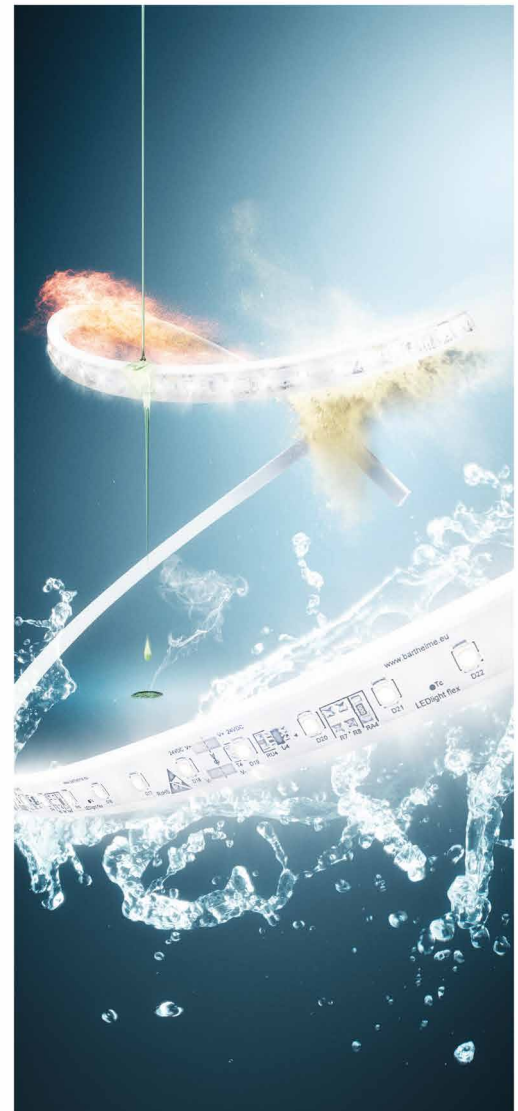

POLYURETHAN GROUTING FOR LED STRIPES

PROTECTS WELL AGAINST WATER, HEAT,
SAND, SALT, CHEMICAL SUBSTANCES AND
MECHANICAL STRESS

VARIOUS KINDS OF GROUTINGS
FOR VARIOUS APPLICATIONS AVAILABLE

Barthelme
LED Solutions[®]

www.aqualuc.de

VISIT US AT THE **LpS 2014**

BOOTH
NO. **A14**

SEPT 30th - OCT 2nd 2014 | BREGENZ | AUSTRIA

Figure 5: Illustration of the importance of atomic lattice match for semiconductor material and defect generation when GaN is deposited on foreign substrates

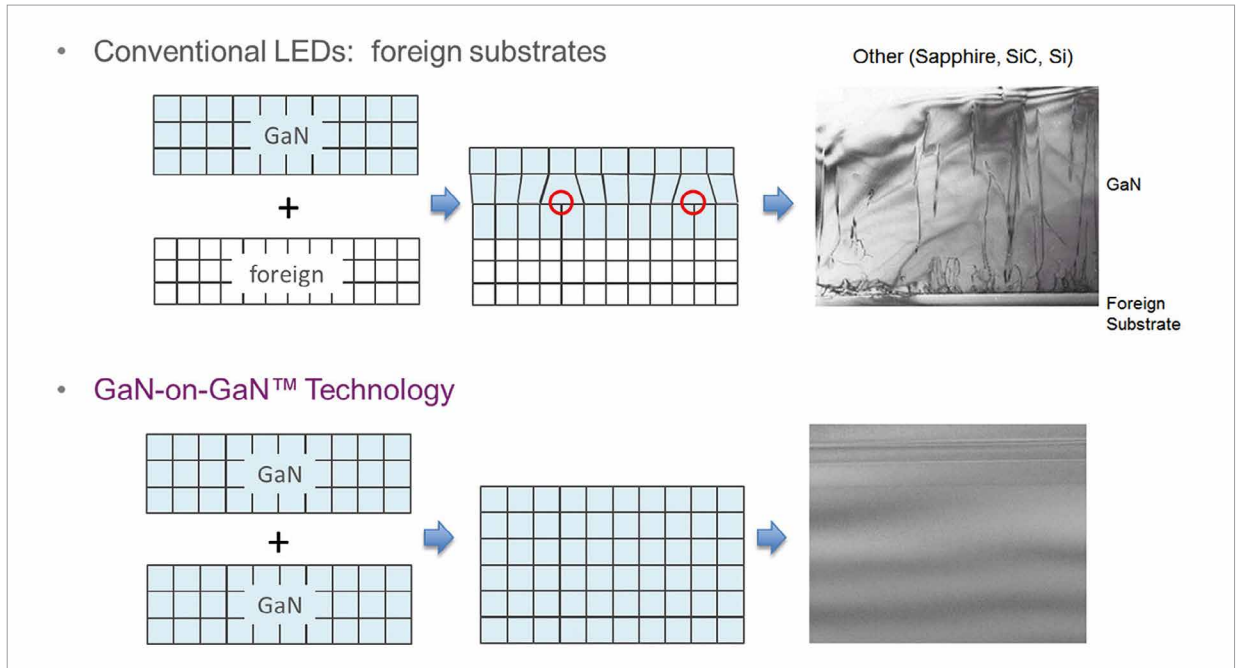

laser diodes (which operate at about 1,000 A per square centimeter, A/cm²) cannot reliably operate at such defect levels. In contrast, GaN deposited on its native substrate provides for very low defect densities, about 100-1,000 times lower (Figure 5, bottom).

Where do the GaN substrates come from? As mentioned, laser diodes could not tolerate the high defect densities associated with foreign substrates. Thus, Blu Ray technology was driven to provide higher quality templates for GaN epitaxial growth. The most common approaches, developed over the last decade, involve starting with a foreign seed substrate but then growing thick GaN layers by hydride vapor-phase epitaxy (HVPE), several mm thick. The very thick growth provided a means for defect annihilation such that reasonably high quality, quasi-bulk, GaN substrates could be realized. While still the most common approach today, it results in relatively high price substrates. New methods, such as ammonothermal growth (analogous to hydrothermal growth of quartz crystals, a very high volume and low cost technique), are being developed that are expected to slash the costs of GaN substrates in the future, while also improving substrate quality by skipping the step of starting with foreign seed crystal.

The impact of the lower defect density, or higher crystalline quality, of the GaN-on-GaN material is higher overall performance, especially at shorter LED emission wavelengths. Figure 6 shows the external quantum efficiencies of LEDs as a function of peak emission wavelength. The lower curve, based on published performance for GaN-on-sapphire LEDs, shows a maximum under 60% in the blue wavelength regime, and falling precipitously as wavelength is reduced below 430 nm. In contrast, GaN-on-GaN devices have external quantum efficiencies above 70% in the blue, and increasing towards 80% in the violet (410 nm) wavelength regime. The extremely high performance level (about 8 out of every 10 electrons injected into the GaN-on-GaN LED are converted to a useful particle of light) provides a sound basis upon which to build an LED platform that supports the full visible spectrum approach described earlier.

Another benefit of GaN-on-GaN is the unlocking of viable high-current density operation. Standard LEDs typically operate at ~ 35 A/cm² (e.g., 350 mA in a 1 mm x 1 mm chip) with higher current density operation thwarted by reduced efficiency (aka “droop”), poor power density uniformity, and (eventually) reliability concerns. In contrast, GaN-on-GaN devices typically operate at ~ 160 A/cm²,

about five times higher than standard LEDs [4]. This means that, for same light output level, the GaN-on-GaN approach requires five times less semiconductor material. There are two significant ramifications. One, it portends a fundamentally lower cost approach to LED manufacturing, especially as GaN substrate prices come down. Since factories will likewise be correspondingly smaller, it also represents a more sustainable approach to LED manufacturing. Two, the reduced amount of semiconductor required means also that the total optical source size of a GaN-on-GaN light source can be significantly smaller than for traditional LEDs. This means increased control over light including tighter beam profiles, and fundamentally smaller optics and luminaires which will drive more elegant and sustainable lighting product designs. The full ramifications of all the above are best revealed when analyzing performance at the system, or lighting product, level.

Directional Lighting Comparison

As such an illustration, figure 7 compares two commercial spot lighting solutions with high color rendering: A state-of-the-art high-end conventional LED fixture, and a violet-based full-visible-spectrum Alamp for AR111 fixtures.

Figure 7: Comparison of a directional lighting fixture based on standard blue-based LEDs, to AR111 performance using GaN-on-GaN

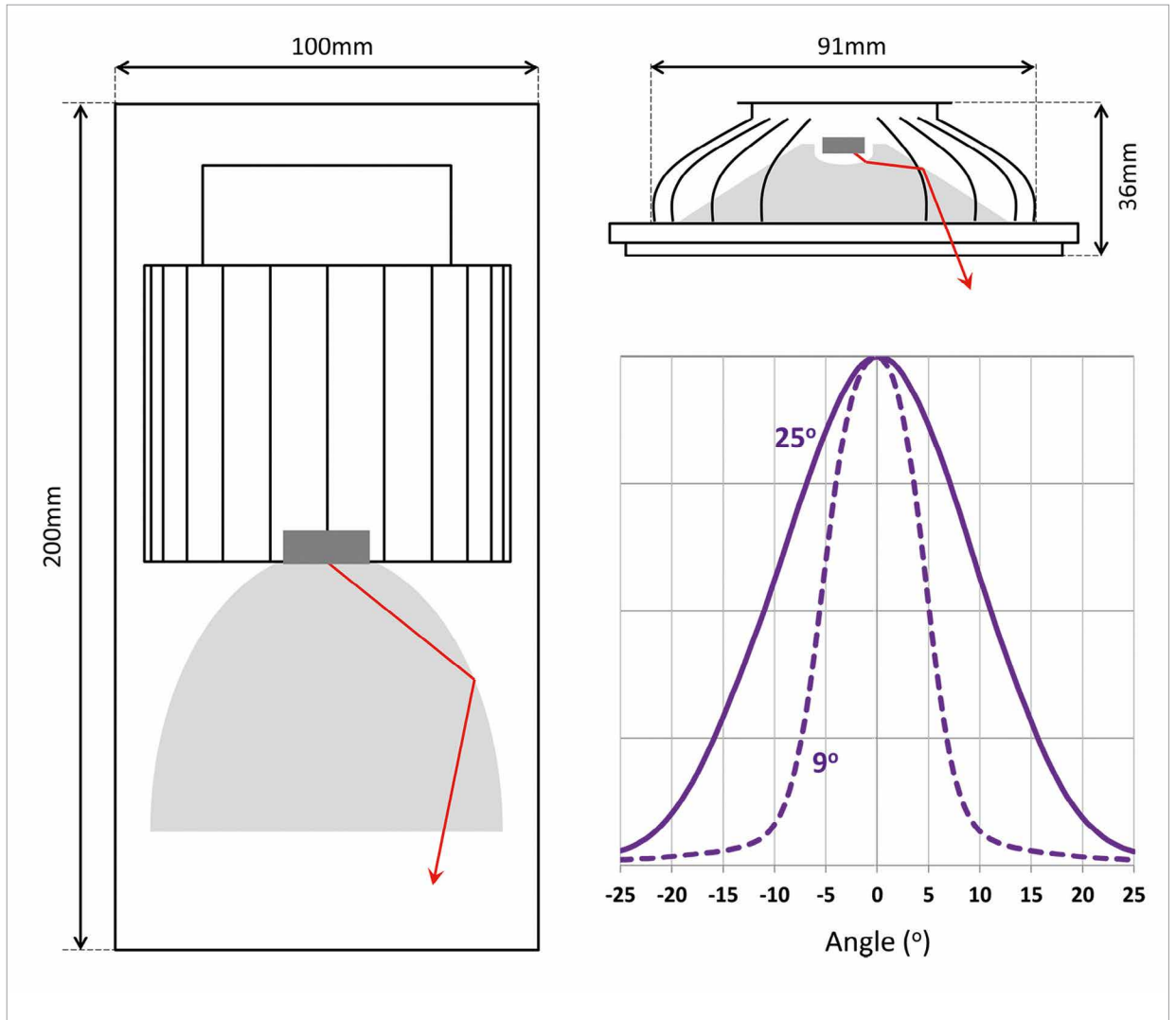

Both sources have similar diameter, power consumption and a 25° beam angle. The conventional solution uses a standard approach: A blue-emitting-LED based high-power light module is attached to a heat sink and coupled to a parabolic optic. The violet-based full-visible-spectrum AR111, in contrast, takes on a drastically different geometry: Both the heat sink and optic are design to couple optimally to the high-brightness GaN-on-GaN light source.

Several advantages of the GaN-on-GaN technology are obvious. First, the system is brighter and more efficient: It emits a 10% higher center beam candlepower (CBCP) and achieves 20% higher Lumens per Watt. This is on top of offering a superior color rendering and whiteness rendering (these could be offered by conventional technology, but at a further cost on efficiency and light output).

In addition, the GaN-on-GaN based system is significantly smaller: It has the same diameter but is more than six times thinner. This is enabled by several factors. The high-efficiency GaN-on-GaN LEDs require much less heat sinking. The high-brightness source, coupled to an innovative folded-lens design, provides a much tighter beam control in a very thin optic. Finally, while standard fixtures require a deep cup to cut-off large-angle beams which are deleterious to color constancy over angle, full-visible-spectrum technology doesn't rely on the leakage of blue light to achieve color-targeting: This results in inherently superior color-over-angle so no additional blocking or mixing is necessary. In this respect, it is noteworthy that conventional fixtures typically have a fairly high color variation – sometimes five to six

Du'v' points: This within-beam variation is thus much worse than the claimed part-to-part color control, on the order of 2-3 points.

In fact, a 25° beam is far from the limit enabled by GaN-on-GaN technology; with the same footprint, beams down to 9° can be achieved. As can be seen on figure 7, this corresponds to a CBCP of 24,000 candelas. Obtaining such a bright and narrow beam with a conventional reflector-based optic would require a doubling of the system's diameter – clearly an unacceptable solution in most applications. The low-profile footprint provided by the GaN-on-GaN approach is also important because it conforms to the AR111 form factor, and is therefore compatible with a wide range of lighting fixtures suited for various interior design needs.

To put our comparison into perspective, it is instructive that the aforementioned shortcomings of conventional LED products are often obscured: Many specification sheets do not reference important parameters such as R9, whiteness rendering, color-over-angle – even CBCP is sometimes deemphasized in favor of lumens, a much less relevant metric for spot lamps.

Conclusion

The above comparison illustrates that the benefits of full-visible-spectrum technology are not easily reduced to a few conventional metrics, but have huge ramifications to overall product design, cost, efficiency, and quality of illumination. It is worth noting that GaN-on-GaN technology; the real enabler here in breaking the quality-efficiency tradeoff, is still relatively

young: Further improvements can be expected in terms of efficiency, but also in terms of continued higher brightness (even smaller source sizes!) and cost. This technology therefore represents a significantly new approach towards addressing the opportunity to reduce worldwide energy consumption with respect to lighting, while also providing for beautiful illumination. ■

References:

- [1] M. Wei et al., "Perceptual Responses to LED Illumination with Color Rendering Indices of 85 and 97: Is a 12-point Difference Important?" submitted for publication (2014)
- [2] K. W. Houser et al., "Whiteness Perception under LED Illumination", LEUKOS 10:3, 165-180 (2014)
- [3] S. Nakamura and M. R. Krames, "History of gallium-nitride-based light-emitting diodes for illumination", Proceedings of the IEEE 101, 2211-2220 (2013)
- [4] M. J. Cich et al., "Bulk GaN based violet light-emitting diodes with high efficiency at very high current density", Applied Physics Letters 101, 223509 (2012)

acal^{bfi} European leader in advanced technology solutions

VISO
SYSTEMS

The Goniometer revolution: measure any light source within seconds

Simply measure lumen, beam angle, CRI, colour temperature and lumen per watt and export the data easily to IES / LDT / PDF

Pre-calibrated plug and play solution



See
the products
at booth C17
LpS 2014
in Bregenz

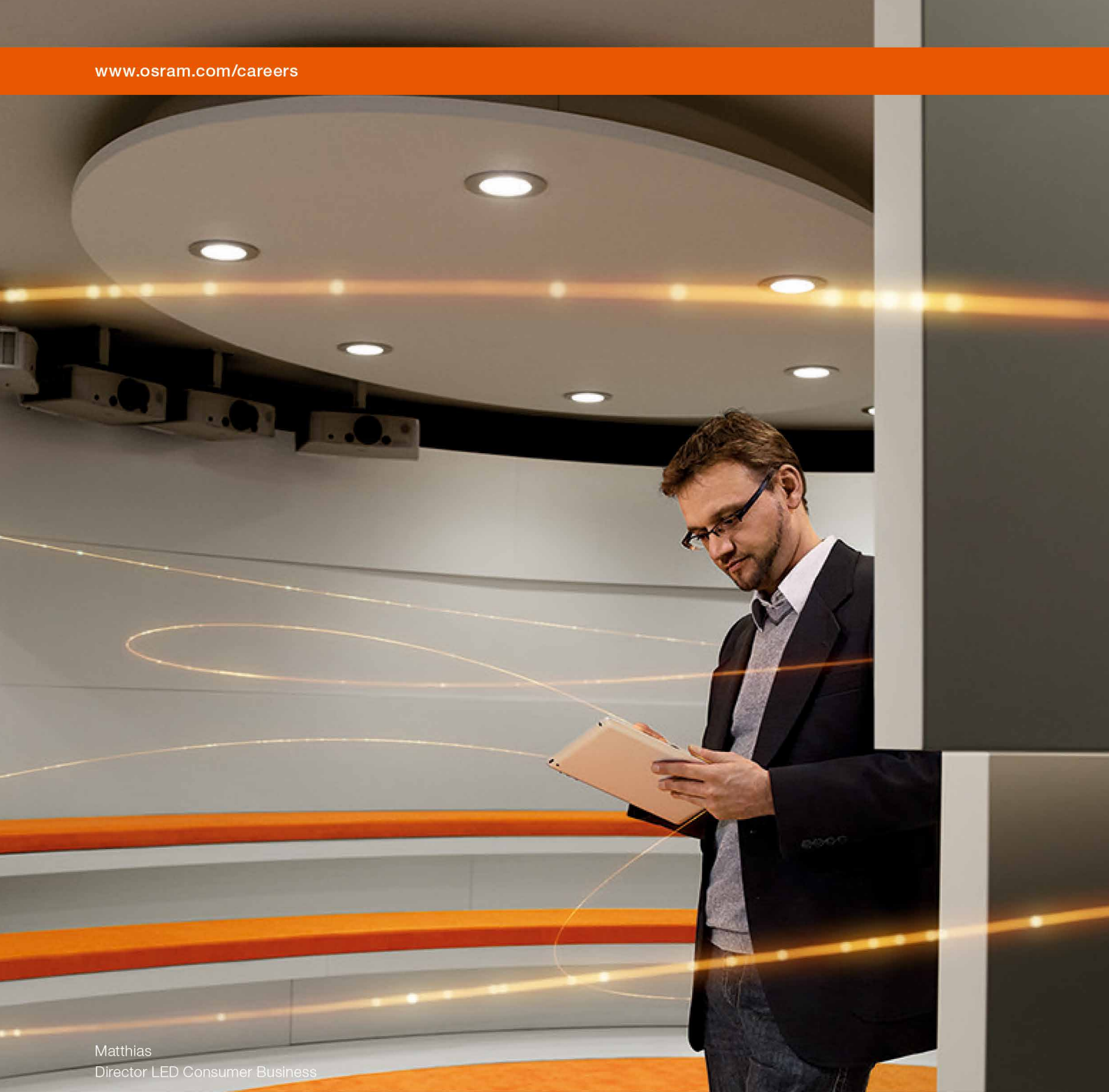

Matthias
Director LED Consumer Business

Light is my world
Consistency meets courage.
That's how we develop products.

Light is OSRAM



Light Guide Technology for Obtaining a Different Bi-Directional Direct/Indirect Light Emission Pattern

Market requirements ask for a solution for use in suspended light fixtures that will allow the light to be distributed upward, for indirect illumination, as well as downward, for direct illumination. However, existing light guide technology typically produces fairly indirect light and relatively uncontrolled distribution. Brett Shriver, Vice President at Global Lighting Technologies, explains a new approach with individual light extraction features used within the light guide in order to control light in multiple directions and provide the required semi-Lambertian distribution in the downward direction with low glare while obtaining a bat-wing type distribution in the upward direction.

As lighting fixtures convert from traditional semi-Lambertian emitting sources such as incandescent and fluorescent bulbs to directional LED light sources, there have been significant challenges in distributing the light efficiently where desired. New developments, as well as existing technologies in LED edge-lit light guides, are allowing manufacturers of these lighting fixtures to produce distinct lighting distributions uniformly and efficiently.

LEDs are inherently directional with regards to their distribution and this is amplified when the packaging of these devices includes reflector cups in order to increase the on-axis brightness of the product. When general lighting manufacturers utilize these devices without secondary optics, they produce spotlight

type distributions that are not always suitable for the final product. There has also been the necessity to locate individual devices so that the beam angles cover the entire area that the design requires to be illuminated. Many times, this results in the end user observing a non-uniform light distribution (bright spots and streaks) caused by the bright on-axis light. Until recently, manufacturers avoided these issues by adding heavy diffuser plates to limit bright spotlighting and adding strips of LEDs pointed in multiple directions and locations that require illumination. These manufacturers are now finding a new use for light guide technology that has already been developed.

Introduction

For more than a decade, consumer electronics manufacturers have used LEDs to illuminate their devices including LCDs, logos, keyboards and keypads - by utilizing clear plastic light guides in order to distribute the light evenly and uniformly. Due to many of these devices being extremely limited on power consumption, it is important that these light guides are very efficient and cost effective. Unfortunately, however, there is not a direct transfer of technology in order to use these devices in general lighting in most cases. Manufacturers of lighting fixtures have used different metrics and measuring devices that require new testing of LED products. The measurement of consumer electronics light guides is typically based on surface brightness per square meter and life expectancies are based on the average life of the electronics devices. The general lighting industry, however, requires measurement of the total light being

QFN LED FEATURES

EMC lead frame,
Small size, high power,
Max Ta:105°C, Typical Rth:10°C/W.



QFN-2835



QFN-3020



QFN-4014

QFN-2835 series 1W

QFN-3020 series 0.5W

QFN-4014 series 0.8W



深圳市瑞豐光電子股份有限公司
SHENZHEN REFOND OPTOELECTRONICS CO.,LTD.

Stock code: 300241

E-mail:sales@refond.com

Tel:(+86)755-66839118

Fax:(+86)755-66839300

www.refond.com

Welcome to visit Refond' s Booth
Hong Kong International Lighting
Fair (Autumn Edition 2014)

Booth No:CR-A15,17;CR-B16,18

Time:oct .27-30,2014

projected from the fixtures into a room or onto a table or other objects while life expectancies are much longer due to expectations that fixtures are not quickly replaced or obsoleted in the manner as consumer electronic devices are.

The Hurdles

The largest hurdle to overcome in the transition, however, is that fixture manufacturers have been primarily interested in the distribution and intensity of light that is projected from the fixture into the room or space being illuminated, whereas, historically, light guide manufacturers have mainly been interested in the distribution and intensity of light at the surface of the

product. This was easily addressed in linear troffer lights by utilizing standard light guide technology and adding light management films to the products. After this adoption, however, many of the requested distribution models began to include light emitting from multiple surfaces and in multiple directions from the source. Although these requests were new, they were entirely within the capabilities of light guide technology but required additional development.

A second hurdle is with regard to what optical extraction technology is used within the light guides. There are many different technologies used within the light guides, including printing and etching as

secondary operations performed on plastic sheets of material, etched or machined features within a mold or tool, or etched and machined features used on thermal embossing equipment. Most of the current fixtures using light guides have utilized the higher efficiency etched and lensed designs. An example of some of these structures can be seen below.

Requirement, Solution and Result

Many manufacturers have asked for a solution for use in suspended light fixtures that will allow the light to be distributed upward, for indirect illumination, as well as downward, for direct illumination. This was possible using existing light guide technology, as it had been developed for products such as flip phones with dual displays utilizing a single light guide. These light guides, however, typically produced light in a fairly indirect and relatively uncontrolled distribution. The more common request has been for a semi-Lambertian distribution in the downward direction with low glare while obtaining a bat-wing type distribution in the upward direction. This would allow for the room below the light to be evenly illuminated, while the upward light would illuminate the walls and surfaces to the sides of the fixture, creating an indirect illumination. This has now been accomplished by designing the individual light extraction features used within the light guide in order to control light in multiple directions. By changing the angle of these features, light can be directed substantially in the direction and area requested by the fixture manufacturer. In order to achieve a separate distribution in the upward and downward direction, different structures and extraction features can be used on each surface of the light guide. One such distribution is shown in figure 3.

However, if the fixture manufacturer is interested in a slightly different profile, such as changing the angle of the light contained within the upward distribution, it can be achieved by varying the angle of the extraction features if the customer is using the machined

Figure 1:
Etched light
extraction feature

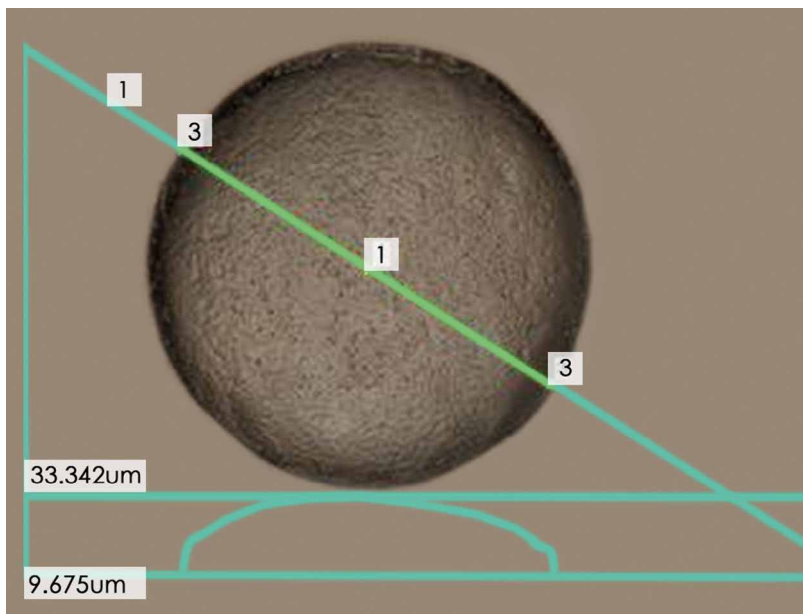

Figure 2:
Lens-based light
extraction feature

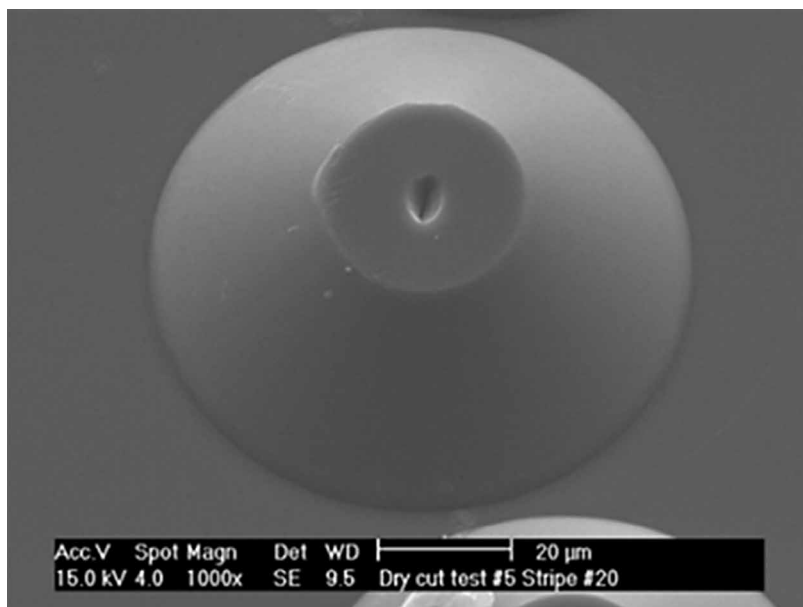

Figure 3: Light distribution diagram showing a separate distribution in the upward and downward direction

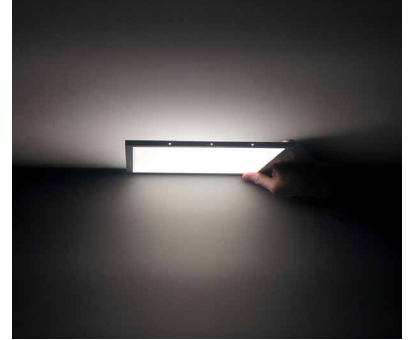
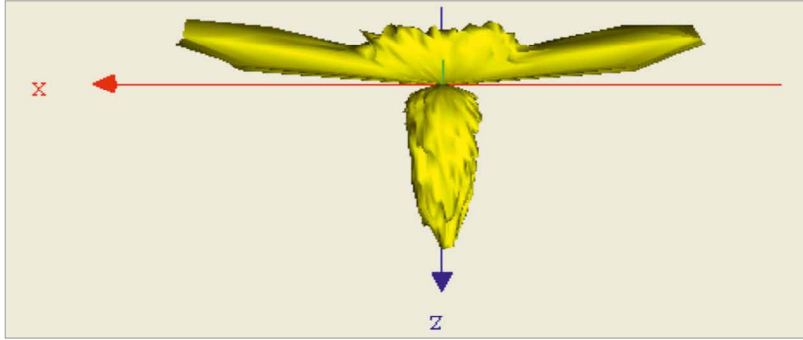

Figure 6: Practical application example of the demonstrated technology

features discussed earlier. Although the included angle of the optical extraction features is typically in the 40° range for LCD backlighting, by varying this angle of the lens relative to the surface of the light guide from 40° to 50°, or even 60°, the angle of the light being emitted from the light guide can be customized. The graphs in figures 4 a-c represent distribution plots of the light emission angle using a 60°, 50° degree, and 40° included angle for the optical extraction features.

As you can see by reviewing the plots, as the included angle of the extraction feature decreases, the distribution of light becomes less parallel with the light guide and closer to perpendicular downlighting. There is a limit to this, however, and, in some instances, it is necessary to add secondary optics and films to achieve specific distributions. If the angle of the

extraction feature becomes too great, the light contained within the light guide is reflected instead of being refracted and is not emitted from the surface of the light guide. For this reason most light guides utilize lenses between 40° and 60°.

The already described refraction of light, caused by the index of refraction of the material, results in some of the light rays being emitted out of the side of the opposite of the normal direction of emission. As the included angle of the light extraction feature is changed, the light that interacts with the features will be refracted out of the bottom of the light guide instead of reflecting toward the top surface and can then be utilized as usable light although in the direction opposite the primary distribution. In many products, the design will include a reflective film

used to direct this light back upward in the direction of the intended distribution. This recycled light returning through the light guide after interaction with the reflective film will, in many cases, be a semi-Lambertian distribution if utilizing a white reflective film. This light will have an effect on the total distribution plot of the light emission. However, in most cases it will be a minor element. There is another opportunity to utilize this light, though.

An additional effect of the extraction features, caused by the index of refraction of the material, is the refraction of some light out of the side of the light guide containing the features. As the included angle of the light extraction feature is changed, some of the light that interacts with the features will be refracted out of

Figures 4 a-c: Plot of 60, 50, 40 degree upward distribution achieved by varying the angle of the extraction features

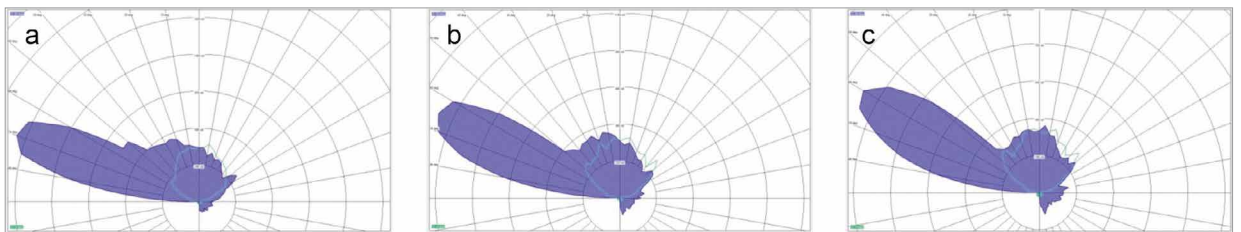

Figures 5 a-c: Three examples of the achievable up/down distribution

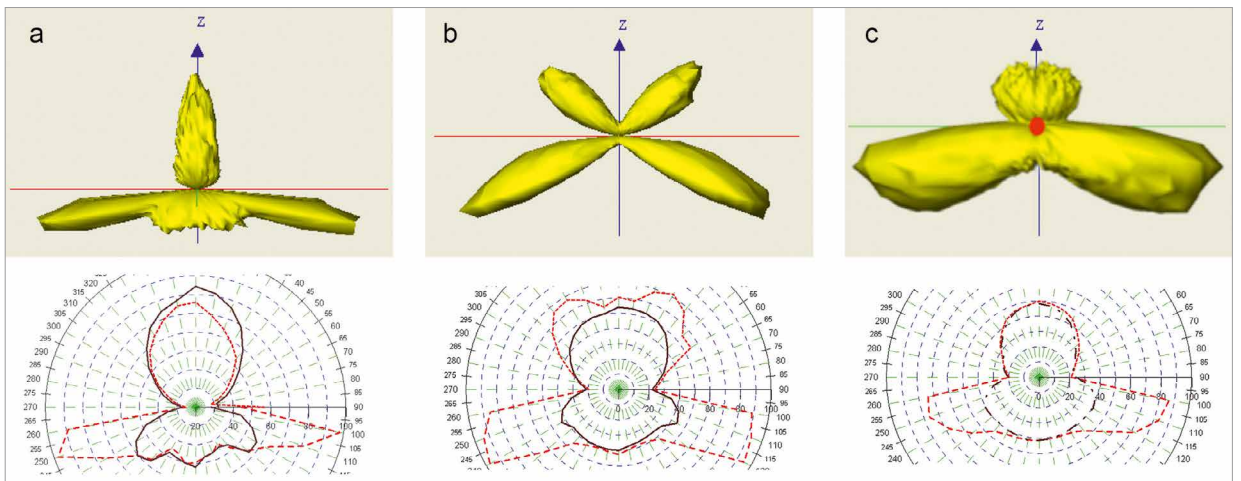

the bottom of the light guide instead of reflecting toward the top surface. This light is then emitted out of the panel as usable light. In many products, the design will include a reflective film used to direct this light back upward in the direction of the intended distribution. There is another opportunity to utilize this light, however. Through manipulation of the extraction features, the light guide, without the reflective film, can be used to achieve the distinct up/down distributions that are shown in the images below.

This method for utilizing edge-illuminated LED light guides now allows fixture manufacturers to achieve unique upward and downward distribution without having to direct individual banks of LEDs in each direction. The distributions available by combining the various optical features described earlier can vary greatly and can meet numerous requests from fixture designers with small variations in design. This technology is currently enabling very thin and even translucent light guide bi-directional fixtures that are now being introduced to the market.

Conclusions

The number of possible uses for this technology continues to grow as designers are exposed to, and educated on the possibilities. The optical design, mechanical design, and production of these products remains very specialized, with only a small number of companies capable of providing these specialized products. When implemented properly, however, the result in very impressive usage of new LED lighting technology. ■

LED CHINA 2015

The World's Largest LED and LED Lighting Event
16 - 19 September 2015
Shanghai New International Expo Centre

- 80,000 sqm in exhibition space
 - 90,000 domestic & overseas visitors
 - 1,200 exhibitors and brands
- (The above are projected numbers)



EdiPower Special Light Series



☞ Enhance the visual appeal of merchandise effectively

☞ High CRI: brings out the actual luster of objects

☞ Especially suitable for colorful accent lighting



▲ Clothing Lighting



▲ Bakery Lighting



▲ Fresh Meat Lighting



▲ Skin Lighting



More info

Copyright©2014 Edison Opto Corp. All rights reserved.

www.edison-opto.com



UE Electronic

Since 1989

35W indoor LED driver, built-in fan,
can be matched and installed by users



35W indoor LED driver (UEL035-D2)
12-36V DC 0.1-0.9A
EN61347, UL8750, GB19510



66W standard outdoor LED driver
66W outdoor LED driver (UEL066-A1Z)
9-188V DC 0.35-5A
EN61347, UL8750, GB19510



PSB BSMI SABS WEEE ISO 14001:2004 ISO 9001:2008 CEC OHSAS 18001:2007



Fuhua Electronic Co., Ltd

Fuhua Electronic Industrial Park, Xianglong Rd., Huangzhou, New Town, Shilong, Dongguan, Guangdong, China

Tel: (86) 769-8602 2222 Fax: (86) 769-8602 3333 www.fuhua-cn.com E-mail: fuhua@fuhua-cn.com



官方网站

官方微信

UE Electronic

Improving the Lifetime of Components Using Heat Conducting Plastics

During the past decade, heat conductive plastics have made a great amount of progress. This material offers great design opportunities when correctly processed and can help to extend the lifetime of components and products. Today, thermally conductive plastics with different properties are available. Thies Wrobel, Product Specialist and Klaus Gebhardt, Product Development Specialist at Albis Plastics explain the relevant parameters and show how to select correctly and apply properly.

Figure 1:
The definition of heat flow

Electronic components frequently suffer significant power losses in the form of converted heat. It is necessary to dissipate this heat to increase the service life of the components and prevent premature failure. For this reason thermally conductive plastics have been under development for a number of years and are being used more and more frequently for thermo-management, e.g. as heat sinks for LED's. This is possible by modifying the thermal conductivity (λ) of plastics, which are normally thermally insulating.

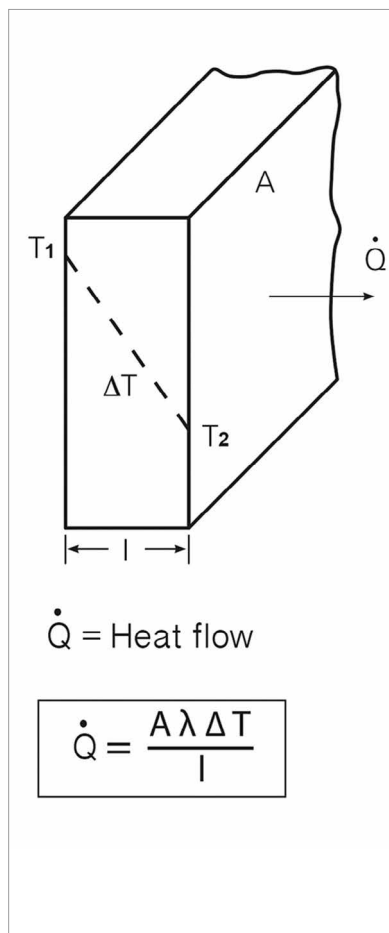

Thermal Conductivity

Thermal conductivity λ (TC) is a decisive property for determining the heat flow Q through a body with flow area A . According to the 2nd Law of Thermodynamics heat always flows in the direction of lower temperature. This temperature difference ΔT is the “driving force” or the potential for the heat flow. λ is the variable for the rate of temperature equalization.

The heat conductivity equation (Figure 1) indicates the amount of heat flowing through a body at a given temperature difference:

- Q Heat flow
- A Cross sectional area of body through which heat flows
- λ Thermal conductivity
- ΔT Temperature difference
- l Length of body through which heat flows

In this equation λ is a material and temperature-dependent property:

$$\lambda(T) = \rho(T) \cdot c_p(T) \cdot a(T)$$

- $\rho(T)$ Density
- $c_p(T)$ Specific thermal capacity
- $a(T)$ Thermal diffusivity

Figure 2:
Hot Disk (ISO 22007) - result: Integral conductivity

The Importance of Being Familiar with Thermal Processes

Knowledge of thermal properties is of major significance for production of components and processing of materials. Typical questions on this subject include:

- How quickly does the temperature in a component change when a certain material is used?
- What temperature difference is required to heat up a body within a specified time?
- How can thermal conductivity be influenced?
- How should a component be designed when $\lambda(T)$, $\rho(T)$, $c_p(T)$, $a(T)$ are defined?
- What other possibilities are available?

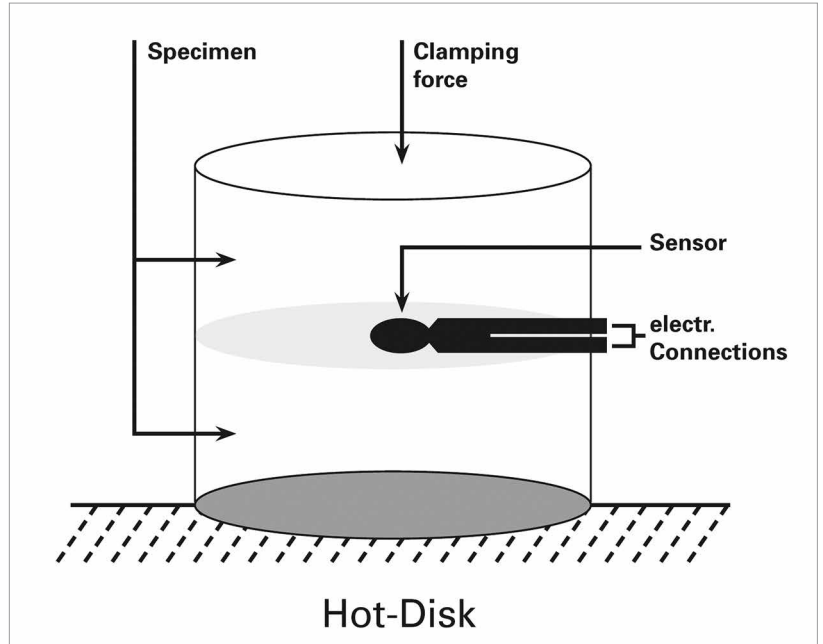

Figure 3:
Principle of Nano or Laser Flash, (ASTM E 1461) - the result depends on the direction; "In-plane": In the direction of flow / longitudinal to fillers; "Through-plane": 90° perpendicular to filler orientation

Measuring Procedures and Parameters

Answering these and other questions requires knowledge of the decisive material properties and suitable measuring processes for their determination. The most common processes and the resulting ratings are listed below:

- Hot Disk - Integral thermal conductivity: $\lambda(T)$ [W/mK]
- Nano Flash - Directional thermal conductivity: $\lambda(T)$ [W/mK]
- Nano Flash - Thermal diffusivity: $a(T)$ [mm²/s]
- DSC - Effective heat capacity: $c_p(T)$ [J/(kg K)]

Influencing Thermal Conductivity λ

As mentioned above, the thermal conductivity (TC) is a material property. The characteristics can be influenced highly by the manufacturer of the plastic compound.

Available options

Increasing the thermal conductivity:

An increase in the number of crystallites per unit of volume facilitates the flow of heat through the material. This is represented by the thermal

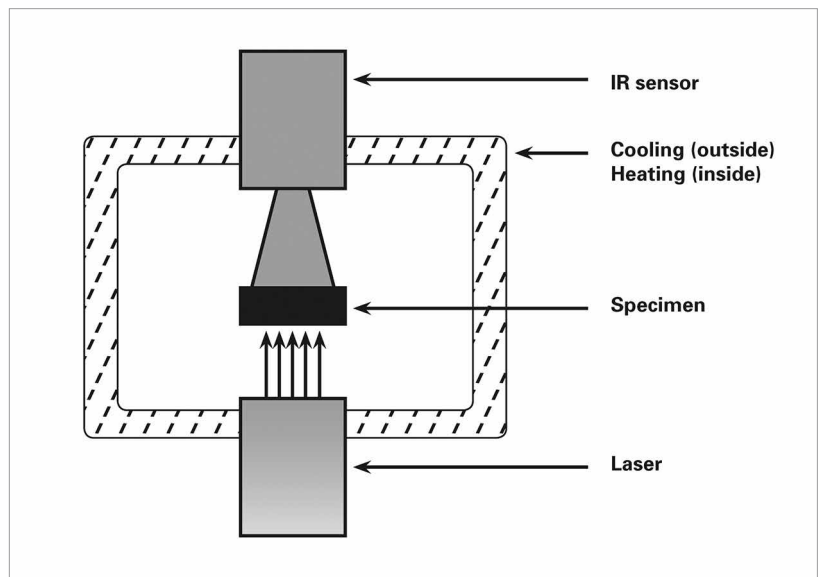

conductivity or thermal diffusivity: Particle-filled thermoplastics are characterized by the degree of particle fill, the shape of the particles, the particle material and distribution of particles in the thermoplastic.

Increase in density:

The density is a proportional factor in determining the TC. This is dependent on proper selection of the thermoplastic matrix material as well as the density of the particle material.

Increase in the specific heat capacity c_p :

Increasing the specific heat capacity also results in a proportional increase in the TC. However the heat storage

capacity of the filled thermoplastic also increases in this case. This means that the heat can flow into the component rapidly where it is stored, however its dissipation is comparatively slow. On the other hand, when the heat flow to the "cold" side of the component is ensured (e.g. by convection cooling), the thermal conductivity is also optimized. The heat capacity can also be influenced by proper selection of the thermoplastic material and type and shape of filler particles.

Further options are the selection of suitable filler and thermoplastic matrix which will be discussed in the next chapter and the optimization of the compounding process.

Figure 4: Comparison of thermal conductivity of unmodified PA66 to PA66 with various thermo-conductive modifications (GF = glass fiber, CF = carbon fiber, CU = copper powder, TCE = thermally and electrically conductive filler)

Comparison of Conductive Plastics with Standard PA

Various thermally conductive fillers are available on the market for plastics.

Examples:

- Ceramic fillers e.g. hexagonal boron nitride up to 400 W/mK
- Mineral fillers e.g. aluminum and zinc oxide up to 35 W/mK
- Graphite (up to 1000 W/mK)
- Metals e.g. powdered copper and copper flakes up to 400 W/mK

These materials can be used for production of thermally conductive plastic compounds alone or in mixtures.

The disadvantage of the more economical fillers such as aluminum and zinc oxide as well as some other fillers is their relatively high hardness. During the compounding process this leads to increased wear in the production extruders as well as in the injection molding equipment and injection molding tools during component production.

The thermal conductivity values achievable with mineral fillers are in the range of only 1 to 2 W/mK, whereby the percentage of filler required by weight is high, leading to a notable reduction of the mechanical properties such as the impact strength.

For this reason it is possible to dispense with developments with metallic fillers.

In 2013 the line of fillers was revised to include only those with which it is possible to achieve higher thermal conductivity values while maintaining acceptable mechanical properties and without causing high wear. Initially the basic polymers selected for this conversion were Polyamide 66 and Polyamide 6. These are the most common thermally conductive modified polymers. The combination of high semicrystallinity of these polyamides and their good filler compatibility has led to a significantly higher thermal conductivity in comparison to amorphous polymers (e.g. PC and PC/ABS) with the same percentages of fillers. Within the group of

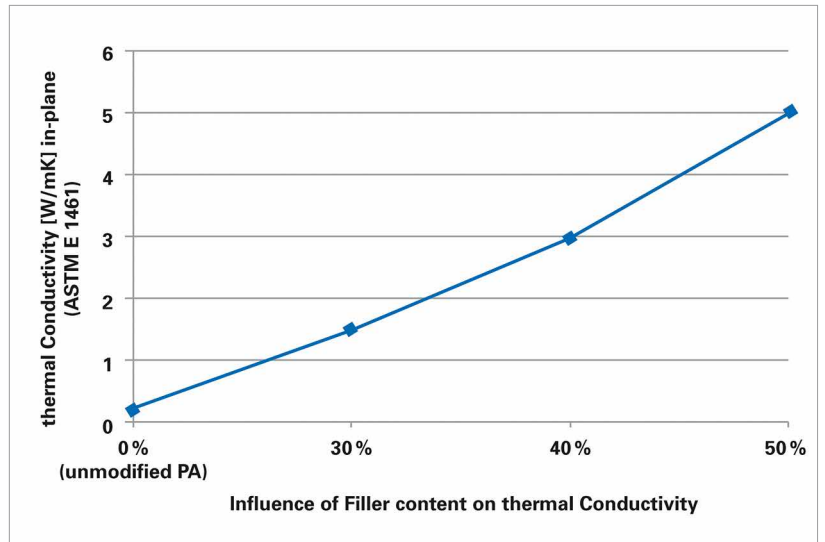
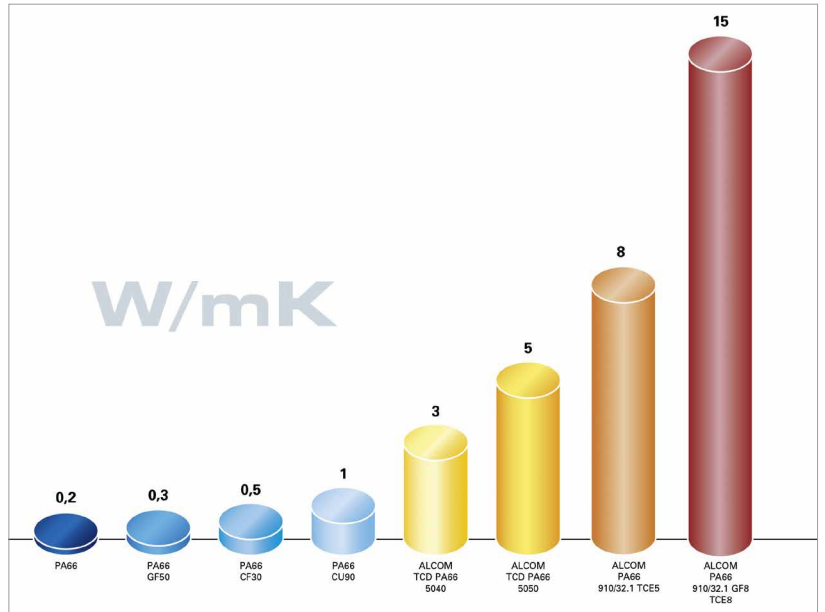

semicrystalline polymers, modified polyamide shows the best characteristics in terms of thermal conductivity.

The following diagram shows how the integral TC is dependent on the quantity and type of fillers used in the polymer.

Here it is evident that simply increasing the density (see PA66 with 90% copper by weight) does not lead to the highest TC value, which can be achieved only with special fillers. The large difference between unfilled and highly modified polymer is clearly recognizable.

Using compounds in different quantities of the same filler results in the effect shown in figure 5.

With thermally conductive fillers modified PA66 has a reasonable higher heat flux compared to unmodified PA66. Therefore it can transport the heat in a better way from the heat source on the ground to the peaks or cooling ribs of the heat sink (Figures 6 a&b).

Comparison of Electrically Insulating and Conductive Materials

The thermally conductive plastics can usually be subdivided into two groups:

- Thermally and electrically conductive products (ALCOM TCE)
- Thermally conductive and electrically insulating products (ALCOM TCD)

This difference results from the use of different fillers.

Figures 6 a&b:
(a) Heat flux of a thermal conductive & electrical insulating material.
(b) Heat flux of PA 66 unmodified

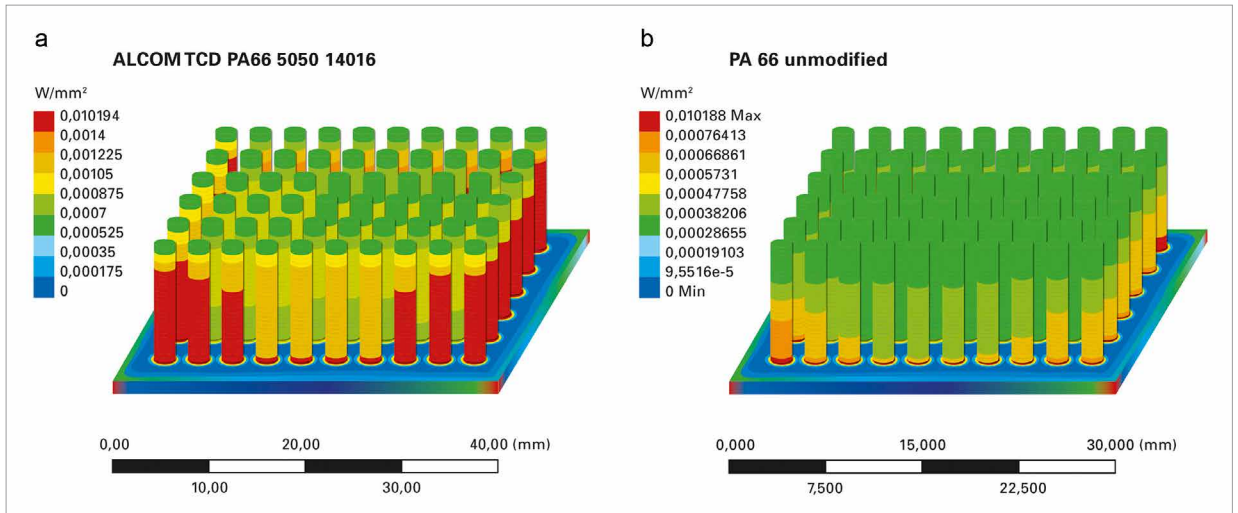
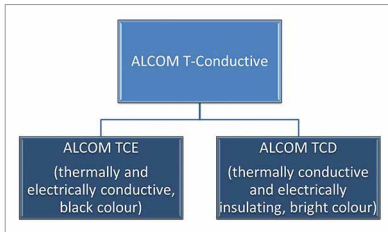

Figure 7:
Two groups of ALCOM T-Conductive



TCE = thermal conductive & electrical conductive:

- Increased thermal conductivity up to 15.5 W/mK, Laser flash “in-plane” (ASTM E 1461)
- Very low electrical surface resistivity of < 1000 Ω
- At certain filler levels, high flame retardancy (V0, tested to UL94) as well as Glow Wire ratings up to 960°C
- Natural color: black

TCD = thermal conductive & electrical dissipative:

- Increased thermal conductivity up to 5 W/mK, Laser flash “in-plane” (ASTM E 1461)
- Flame retardancy can be adjusted using halogen-free additives to achieve V0 at 1.5 mm CTI (Comparative Tracking Index) up to 600 Volts
- Surface resistivity >10¹² Ω
- Dielectric strength of > 50 kV/mm (IEC 60243-1)
- These materials have bright, natural colors and can be pigmented “white”. However, other colors, all the way to anthracite, are also possible

Design

The filler orientation results in a higher thermal conductivity in flow direction and perpendicular (“in plane”). “Through plane” the conductivity will be lower (Figure 9).

Moreover, when designing the component, it is necessary to note, that in addition to the particles aligning themselves in flow direction. They also tend to align themselves to some degree perpendicular to this direction (in Z direction, through-plane). At small wall thicknesses this leads to lower thermal conductivity than at greater wall thicknesses. This is caused by the surface layers “a” (low thermal conductivity in the direction of the wall thickness) and the middle layers “b” (high thermal conductivity in the direction of the wall thickness). In the case of a lower wall thickness, the surface layers “a” are more pronounced, while the middle layer “b” is more influential when the wall thickness is greater. The negative influence of the surface layers “a” on the thermal conductivity in the direction of the wall thickness is therefore greater at low wall thicknesses.

Figure 8:
LED Headlight



Figure 9:
The thermal conductivity is highest in flow direction (designated “in-plane” Nano flash ASTM E 1461), and lowest “through-plane”

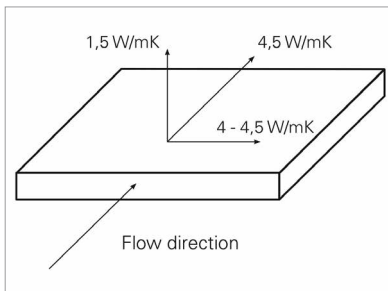
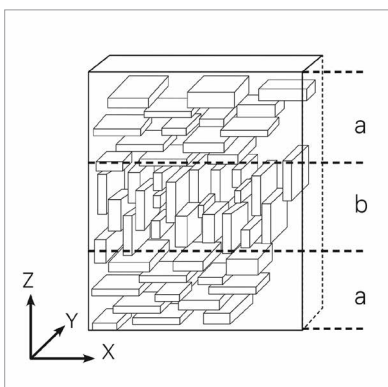

Figure 10:
Filler orientation (Graphic credits: Skrabala/Bonten - Enhanced thermo conductivity in plate-shaped plastic parts)



Applications

The primary areas of application of thermally conductive plastics include heat sinks or housings for electronic components as well as LED components (e.g. reflector housings, Figure 8) often in combination with light-weight design as well as metal substitution.

When designing heat sinks (see graphic) it is necessary to take this effect of the layers into consideration, because otherwise it is not possible to achieve the calculated heat dissipation. It is necessary to design the geometry in a way that the heat can be dissipated on the surface of the component (convection, radiation, etc.) to avoid

Figure 11:
Filler orientation
in a heat sink
 (Graphic credits:
 Dr. Ing. C. Heinle,
 University of
 Erlangen-Nuren-
 berg, 2012 [1])

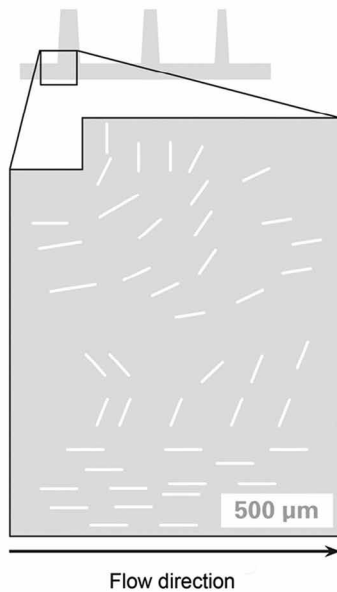

Processing

Thermally conductive plastics are processed primarily using the injection molding process. The high thermal conductivity ensures that the molten polymer dissipates the heat very rapidly, so that the part cools down quickly. Reduced cycle times could be a positive effect. However, in comparison to standard plastics, significantly higher melt and mold temperatures are required to achieve longer flow paths. In some cases it is also necessary to increase the injection speed. Postproduction via vibration welding is possible, however, bonding methods using heat transfer welding techniques are difficult, if possible at all.

In some cases laser marking is possible without additional laser additives. The quality depends on the combination of fillers. The achievable speeds for laser marking, especially for thermal & electrical conductive plastics, are on the borderline in terms of cost effectiveness. For laser marking additional additives should be used.

Benefits of Thermally Conductive Plastics

- Prevention of thermal hot spots
- Protection of sensitive components and increase in service life
- Higher energy densities possible
- High freedom of design
- No corrosion
- Weight reduction
- New approaches to light-weight design and metal substitution
- Energy-efficient mass production (e.g. injection molding)

Conclusion

LED's and electronic components frequently suffer significant power losses in the form of converted heat. It is necessary to dissipate this heat to increase the service life of components and prevent premature failure. Thermally conductive plastics are being used more and more frequently for temperature management. This is possible by modifying the thermal conductivity of plastics, which are normally thermally insulating. Primary areas of use are heat sinks and housings for electronic parts and components as well as LED reflector housings - frequently in combination with light-weight design as well as metal substitution.

Especially in the lighting industry sector both, thermally and electrically conductive products as well as thermally conductive and electrically insulating products have several applications.

In the future, it is a definite possibility to include other polymers to expand application opportunities and further improve properties. Moreover, efforts are in progress to achieve greater isotropic thermal conductivity in the in-plane and through-plane directions. ■

heat accumulation. It is also important to take into consideration the usual guidelines for design of conventional heat sinks, such as contact design without air gaps, e.g. using additional thermally conductive pastes or foils, etc. The gate position on the component must also be well selected. Here it is possible to use calculation tools such as FEA and injection molding simulation, to help avoid errors and ensure optimization from the very beginning.

Figure 12:
Laser marking



TWO-CHANNEL OUTPUT INDOOR LED DRIVER - UEL035-D2

12-36 V, 0.1-0.9 A, two-channel output, built-in fan can be installed by users; Suitable for desk lamp, ceiling lamp and other indoor LED lamp.

www.fuhua-cn.com/en/index.html

fuhua@fuhua-cn.com

ELECTROLUBE
THE SOLUTIONS PEOPLE

Visit us at **Electronica**
HALL A6:131 COATINGS
HALL B1:548 THERMAL

Superior resins engineered for challenging environments

In Encapsulation Resins our comprehensive range meets the increasing demands of the electronics industry. Whether it's epoxy, polyurethane or silicone resin systems, our products are designed to protect and insulate printed circuit boards (PCBs) and electronic components from the threats of harsh and challenging environments.

Encapsulating the entire device in resin offers protection against moisture, vibration and rapid changes in temperature, thus offering superior performance under extreme conditions.

Whether for general purpose or tailored for individual requirements, every electro-chemical solution is within our spectrum. Our specialist approach to problems has established us as a key provider and developer to the technical electrical industry, both commercial and domestic.

Isn't it time you discovered how Electrolube can serve you?

+44 (0)1530 419600
www.electrolube.com

Scan the code to discover our full spectrum of superior Encapsulation Resins and electro-chemical solutions.



Electronic & General Purpose Cleaning

Conformal Coatings

Encapsulation Resins

Thermal Management Solutions

Contact Lubricants

Maintenance & Service Aids

shat-r-shield® INC.
The Protective Lighting Company

Do you use protection?

IP68 Waterproof - Safety Coated Lamps

Protects fragile electronic components from moisture & corrosion in harsh environments.



- Landscape Lighting
- Wash Down Areas
- Dock Lighting
- Outdoor Lighting
- Marine Environments

tel: (800) 223-0853

shat-r-shield® INC.
The Protective Lighting Company

Do you use protection?

Precision Conformal Coating Service
Patented technology for coating over the LED.

Protects fragile electronic components from moisture & corrosion in harsh environments.

- Aerospace
- Architectural
- Signage
- Security
- Commercial

www.shatshield.com



Advanced Passive Thermal Management Solutions for High Power LEDs

There are two main solutions to improve passive thermal management in LED devices. One is to increase the surface area of a heat sink. This requires additional size, weight and material and offers only marginal improvement. The second solution is to increase the thermal conductivity between the heat source and the sink. The latter is supported by well-established technologies like heat pipes and vapor chambers. Richard Bonner, Manager for Custom Products, and Peter Ritt, Vice President at Advanced Cooling Technologies (ACT) give insight into the latest developments and explain how they work, how they are designed and applied correctly, and discuss their opportunities, advantages and limitations.

There are two main solutions to improve passive thermal management in LED devices. One is to increase the surface area of a heat sink. This requires additional size, weight and material and offers only marginal improvement. The second solution is to increase the thermal conductivity between the heat source and the sink. The latter is supported by well-established technologies like heat pipes and vapor chambers. Richard Bonner, manager for custom products, and Peter Ritt, vice president at Advanced Cooling Technologies (ACT) gives insight in the latest developments and explain

how they work, how they are designed and applied correctly, and discuss their opportunities, advantages and limitations.

Heat Pipe Fundamentals

The most typical form factor for a heat pipe is a copper walled tube of 3 to 8 mm in outer diameter. The lengths are highly customizable, but most applications require 4" to 10" long heat pipes. Inside the tube is a wick structure and a small amount of a working fluid. Most LED applications require copper tubes with copper wicks and have water as the working fluid. However, there are several other envelope materials,

wick structures and working fluid combinations for a typical temperature range requirements. A heat pipe transfers heat by circulating the working fluid whenever a temperature gradient is applied, as shown in figure 1. The temperature gradient in LED applications is generally created by the waste heat generated by the LED's in conjunction with a heat sink exposed to ambient air. The applied heat evaporates liquid out of the heat pipe's wick structure. The vapor exiting the evaporator wick is swept to the cold condenser where it condenses back into the wick structure. The wick structure continuously returns the condensing liquid to the evaporator through capillary pressure.

Figure 1:
Heat pipe operation

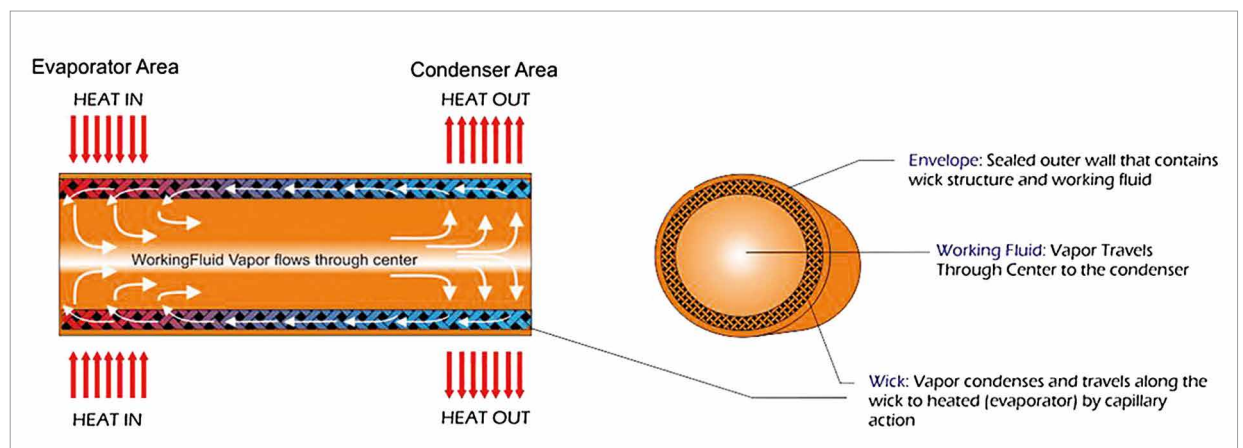

Although heat pipes can appear simple and elegant, many design options must be considered when implementing heat pipes in practical applications. The correct wick structure is key to maximizing performance. The wick's pore size, permeability, and thickness need to be tailored in order to maximize the amount of power that can be transferred. A classical trade off exists between capillary pressure generated by the wick (which increases with decreasing pore size) and liquid permeability (which decreases with decreasing pore size). In preliminary design stages convenient heat pipe calculators capturing these physics can be used to assess feasibility [6].

Fluid inventory control is an important design and processing parameter. Excess fluid can create flooding

conditions within the heat pipe which negatively impacts the thermal resistance of the heat pipe. Fluid inventory is also key to enabling freeze thaw capabilities within heat pipes. Finally, insufficient fluid can cause premature dry-out.

It's important to note that heat pipes can operate against gravity, with the evaporator located above the condenser. Typically, heat pipes can transfer heat as much as ~8" against gravity with a properly designed wick structure, although operating in reflux mode (evaporator below condenser) is preferred. In terms of heat flux capabilities, typical copper water heat pipes can operate with heat fluxes up to 50-75 W/cm². Additionally, heat pipes can be bent and flattened to fit countless geometric shapes.

Heat Sink Performance and Weight Improvement

In some LED lighting applications, such as high bay lighting, large extrusion or cast aluminum heat sinks are used to dissipate heat to ambient air. Placing a discreet heat source on a large metal heat sink will produce large thermal gradients between the heat source and outermost located fins. Embedding heat pipes in the heat sink can increase the thermal conductivity from around 200 W/m-K (for extruded aluminum, even lower for casting alloys) to between 500 and 1,200 W/m-K. Designers can use this increase in thermal performance to reduce the weight or increase the power density of their lighting system. This approach can be implemented in a variety of LED applications including large arrays, outdoor lighting as well as some down lighting applications.

Figure 2: Comparison of aluminum heat sinks. Heat sink (left) is 12" long, with a base thickness of 0.6", and weight of 9.6 lbs. The Hi-K heat sink (right) is 10" long, with a 0.28" base, and weighs only 6.3 lbs

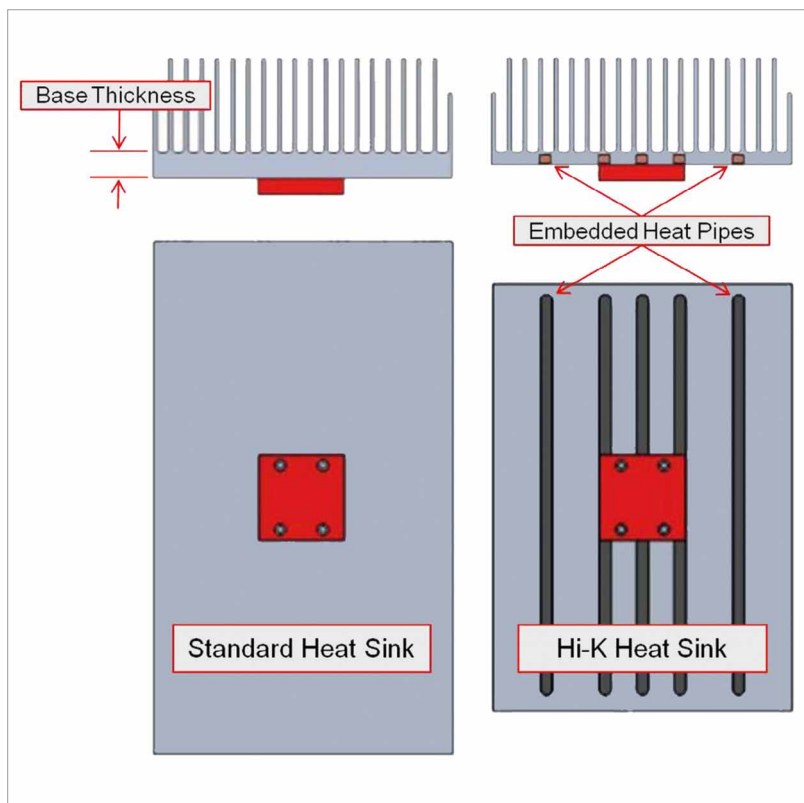
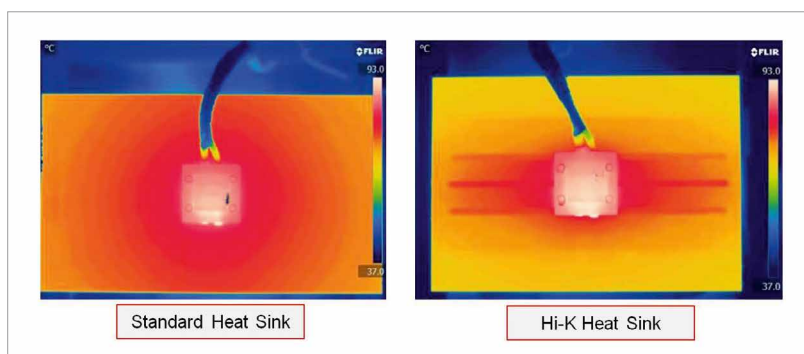

Figure 2 shows a schematic of similar performing heat sinks with and without heat pipes. The conventional metal heat sink is 12" long, weighs 9.6 lbs and has a base thickness of 6/10 of an inch. Introduction of 5 heat pipes, 3 in close proximity to the heat source and another two a little further out for heat spreading, reduces the overall length to 10 inches, and the weight can be reduced to 6.3 lbs. an overall material reduction of nearly 35%. Figure 3 shows a result taken with an IR camera on both of these heat sinks when 150 W of thermal power is applied to each heat sink.

Figure 3: Comparison of test results for standard size aluminum extrusion heat sink (left) and 35% smaller Hi-K heat sink (right). Result shown was acquired using an infrared camera



High Performance Heat Spreading

In a growing number of high power LED applications, such as UV curing devices, overall thermal performance is limited by the ability to quickly spread heat from the high power density sources. These products typically operate at high power, requiring dissipation of hundreds or even thousands of watts, but must maintain tight temperature range so that the output optical wavelength remains constant. The problem is further aggravated because an additional thermal interface layer is needed between the heat source, typically made of some low thermal expansion

Figure 4:
Low coefficient of thermal expansion vapor chamber that allows direct solder attachment of LED devices

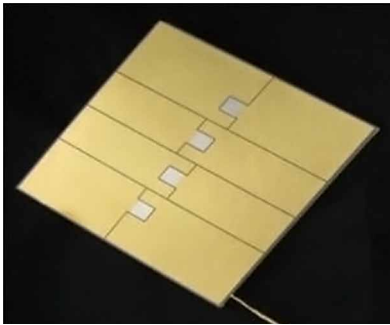
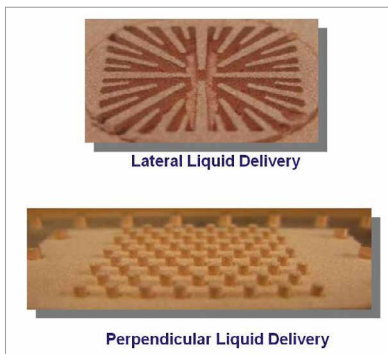

Figure 5:
Advanced vapor chamber wick structures capable of dissipating greater than 500 W/cm² heat fluxes at 0.05 Kcm²/W thermal resistances



semiconductor material, and heat dissipating device, such as copper or aluminum, which have much higher coefficient of thermal expansions (CTEs). Typical compliant interface materials include thermal gap pads and thermal pastes. Without such a compliant thermal interface layer, the different materials' coefficient of expansions will result in the heat source device cracking or severing from the heat dissipating device. Unfortunately the presence of this thermal interface layer increases the thermal resistance and likewise increases the temperature on the LED device itself.

With both heat pipes and vapor chambers, it is most advantageous to have water as the working fluid, for both cost and performance reasons. Copper has been shown to have excellent compatibility with water, but copper has a relatively high CTE and would be thermally mismatched with common high heat load LED devices and would require a compliant thermal interface layer. Additionally, conventional wick structures have limited performance capabilities, which may not always satisfy performance requirements for high heat load devices. The desired solution is to have a water compatible vapor chamber, that is CTE matched to eliminate low performing compliant thermal interfaces in favor of a higher performing (albeit rigid) solder attachment process [7-8]. Such a heat pipe device is available and has been called the low CTE vapor chamber. The CTE matching feature allows semiconductor based LED's to be directly attached to the heat spreader using solder, which is about an order of magnitude better than compliant thermal interfaces.

Additionally, unique high performance wick structures located at the heat source further improve overall thermal performance. There is a combination of very thin and very thick wick material co-located here. The thick wick is constantly collecting the condensate returning the cooler condenser portion of the vapor chamber and is delivering

liquid to the thin wick area. The thin wick can quickly evaporate the fluid achieving very low thermal resistant values. Examples of the thick/thin wick structure can be seen at the bottom of the page with the Lateral Liquid Delivery. This structure has been shown to have a very high CHF critical heat flux, with an evaporator resistance of only 0.05 K·cm²/W.

Conclusions

Specialized LED lighting applications are more commonly requiring thermal management capabilities beyond traditional aluminum heat sinks. When done properly, heat pipes can silently and passively improve thermal performance, limit heat sink size, and increase reliability in LED applications. In many cases, heat pipes can be used to significantly reduce the size and improve the performance of aluminum heat sinks with simple integration strategies. In ultra-high performance applications, advanced heat pipes and vapor chambers can be used to enable the maximum performance using state of the art wick structures and materials that allow for superior thermal interface performance. ■

References:

- [1] Zhang, J., et al., "Research Progress on Packaging Thermal Management Techniques of High Power LED", *Advanced Materials Research* Vols. 347-353 (2012) pg 3989-3994
- [2] Horng, R. H., et al., "Optimized Thermal Management From a Chip to a Heat Sink for High-Power GaN-Based Light-Emitting Diodes", *IEEE Trans on Electron Devices*, Vol. 57, No. 9, Sep., 2010
- [3] Christensen, A., et al., "Thermal effects in packaging high power light emitting diode arrays", *Applied Thermal Engineering* 29 (2009) 364-371
- [4] Fan, A., Bonner, R., "An Innovative Passive Cooling Method for High Performance Light-emitting Diodes", *Semitherm 2012*, San Jose Ca, March 2012
- [5] Pounds, D., Bonner, R., "High Heat Flux Heat Pipes Embedded in Metal Core Printed Circuit Boards for LED Thermal Management", 2014 IEEE Intersociety Conference on Thermal and Thermomechanical Phenomena in Electronic Systems (ITherm), Orlando, FL, May 27-30, 2014
- [6] <http://www.1-act.com/resources/heat-pipe-calculator/>
- [7] Dussinger, P., Sungtaek Ju, Y., "High Heat Flux, High Power, Low Resistance, Low CTE Two-Phase Thermal Ground Planes for Direct Die Attach Applications:", *GOMACTech 2012*, Las Vegas, NV, March 2012
- [8] Luo, Xiaobing, et al., "Low thermal resistance LED light source with vapor chamber coupled fin heat sink", *Proceedings of 60th IEEE Electronic Components and Technology Conference (ECTC)*, 2010

HONGLI TRONIC

LEDs



2835



EMC3030



UV LED

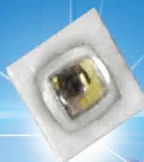

COB



LED filament



2016



Shanghai International Lighting Fair
Booth: Hall 4, H02 DATE: Sep.3-5, 2014
Electronica 2014 (Munich, Germany),
Booth: B6-524/2 DATE: Nov.11-14, 2014

The Leading Manufacturer of White Light LEDs in China

World class production for superior quality LED packaging

Leading light efficacy & superior reliability

Your ultimate LED packaging partner



HONGLI TRONIC

鸿利光电

Stock Code: 300219



E-mail: sales@honglitrionic.com
Tel: +86-20-8673 3333 ext 3033
Fax: +86-20-8673 3883
en.honglitrionic.com

Aspects of Intelligent Lighting

Smart Lighting was one of the most noticed trends at this year's Light + Building. However, it is not clearly defined what Intelligent Lighting or Smart Lighting means or how far reaching the consequences are for users, manufacturers and installers. Thomas Hauer, Project Engineer at RECOM Engineering GmbH & Co KG explains his understanding of these catchphrases and demonstrates a new technical approach.

For some time now, LED manufacturers have been propagating something that is called intelligent or smart lighting, but what is it, exactly?

Classic lighting control is typically limited to simple switches, dimmers, movement detectors and timers. Future lighting systems should be much more people-centric, run intelligently and even act autonomously to provide not only the best possible lighting conditions but also to save as much energy as possible.

This article is a brief introduction to this topic with an overview of how such systems can be realized and what this means for future LED ballasts and their development.

The Network

To realize an intelligent, sensor driven, lighting system you need to combine a lot of different devices into a holistic network to collect, share and make decisions based on the information received. The LED driver is no longer a simple power supply, but an active element in a system consisting of sensors and input-modules such as light-switches, occupancy sensors, color sensors, real time clocks, building control systems and, last but not least, light intensity sensors. All of these devices require some sort of digital interface for intercommunication. The digital interface can be solved basically in two physical ways; wireless or wired.

Wireless Networks

Wireless networks like WiFi, ZigBee or Bluetooth are all based on the carrier sense multiple access approach. Carrier sense multiple access (CSMA) means that every participant on the network first checks if the submission channel is idle before it sends its message. If the channel is currently in use, it waits for a certain time and then listens to the channel again to check if it is idle or not. To stop individual devices hogging the bandwidth, the transmission duty cycle is limited to 1%, so sooner or later every device will find an idle time slot.

A wireless network can be realized without or with a central network master (Figure 1), depending mainly

Figure 1: Principle topology of a wireless network. This topology shows how to create such an application with a gateway and without any meshing

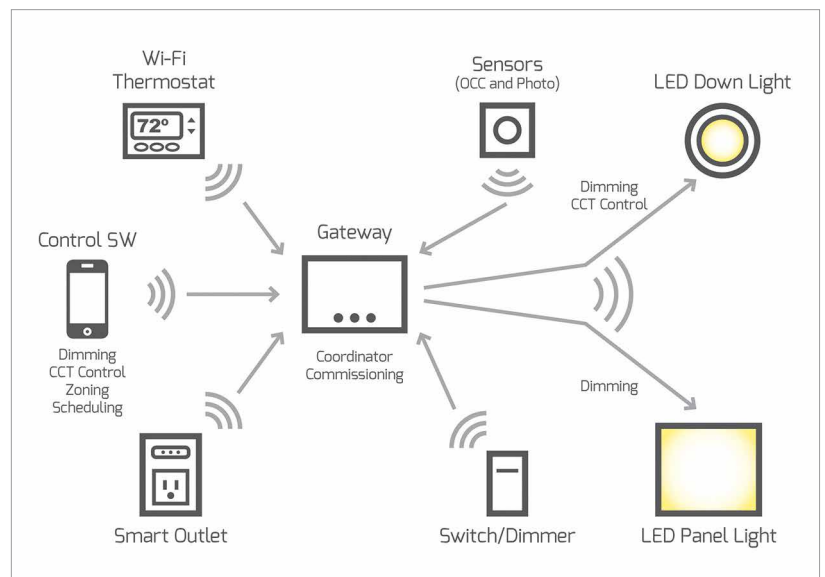

on the complexity of the application where the system is used. In a domestic environment, there is rarely a need for hundreds of different scenes and pre-set configurations as required by a big theatre room or exhibition hall, so the tendency is to construct an ad-hoc or decentralized network without the need for an extensive managed infrastructure.

Very simple wireless networks can be realized with a few human interface devices (HUDs) such as a smartphone or wall-mounted panel and a few networked LED lamps, but this is hardly a big improvement over the classical lighting control systems, except that it is very easy to retrofit controllable lighting into an existing wiring structure as the transceiver can be integrated into the lamp design very easily and with a very small form factor.

Wired Networks

In the wired network system, the network can be realized either with data cables or overlaid upon the power lines using FSK carrier data transmission. Bringing extra wires to an already installed system is often a problem because there is not enough space to put in new wires, especially in old buildings.

Separate data cables are much easier to include in new buildings, and once fitted can be used with a wide variety of control systems and methodologies including 0-10 V, 1-10 V, DALI, DMX, KNX, etc. A power-line communication (PLC) network avoids the need for rewiring, but always needs some extra interfaces and/or custom drivers to inject the control signal onto the power line and to read it off again. There are usually different standards applicable to each PLC hardware arrangement,

so with very few exceptions, each installation is proprietary and incompatible with other PLC systems. As with the wireless network, in the wired world, a network can also be implemented with or without a central bus master, depending on the complexity of the application (Figures 2 & 3).

Wireless vs. Wired

As described in the above introduction, there are basically two different ways to realize a network. Which one to use and what is the best?

The biggest advantage of the wireless network systems is that there is no need for extra wiring and the system is easily expandable to include more luminaires, controllers or sensors. This flexibility arises because they are stochastic networks in which multiple information pathways can exist in parallel and the same input can be processed in different ways. On the other hand, wired data cable networks are said to be deterministic as every cause and effect is established by a fixed set of conditions and rules. This makes them inherently more stable, as well as safer against malicious interference.

As wired data cable systems operate independently, they are generally unaffected by any random events or interference generated by the other networks, be they wired or wireless. This cannot be said to be true for power line communication that uses the same set of wires for power and data. EMC is a very serious topic in PLC systems as power lines are rarely shielded. This missing shielding means that magnetic and electric fields spread out throughout the building as well as being susceptible to external EMC interference from other power devices.

Another consideration that may be important when choosing a network topology is the standby power consumption. Hard-wired data bus systems are usually very low power. For example, the DALI specification permits only 2 mA current draw per device, so even a fully expanded

Figure 2: Principle topology of a wired network with mixed wiring. The information from the main bus can propagate through all devices to the device where it is needed. Due to the fact that there is a main bus line, a central bus master is needed

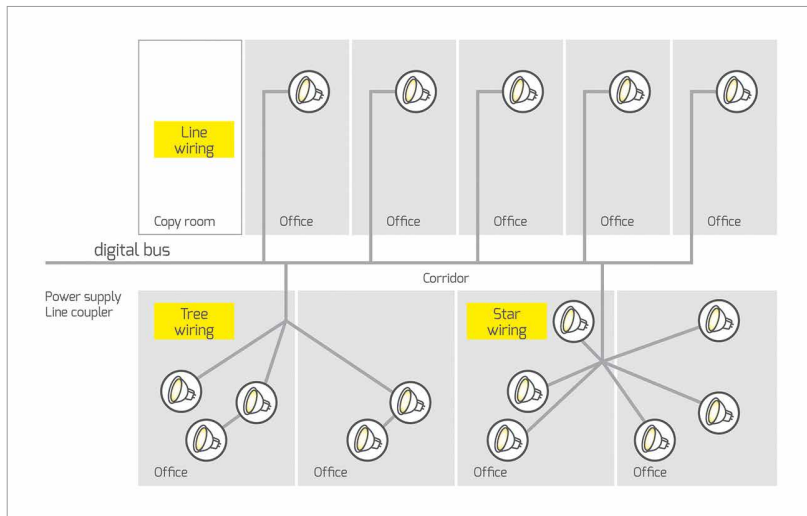

Figure 3: Principle topology of a wired network with DC supply voltage for the lighting and without a network master. The buttons and sensors can be directly addressed to the lighting device where the information is needed

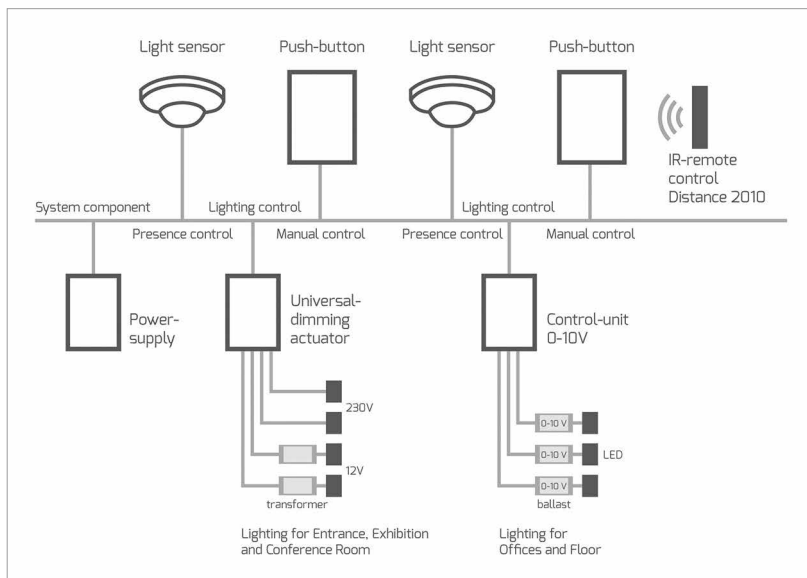

Figure 4:
CSMA Collision
Avoidance Pro-
tocol

system draws only 2 W from the power supply. During inactive periods, the power consumption is merely the standby consumption of the bus power supply, typically <math><0.5\text{ W}</math> to meet ErP regulations. On the other hand, the specification of power line communication devices state that a typical transmitter consumes up to three watts of power to enable it to overlay a strong enough signal on top of the low impedance power lines. When considering a simple 20 W LED – driver, this means 3 watts extra consumption and a decrease of 13% in total system efficiency. That is significant, especially compared to wireless applications where 100 mW is the maximum permitted transmission power.

The vulnerability of wireless systems to malicious interference may sound trivial considering it is mainly used for simple commands such as light on or light off, but for complex systems such as an office building or in a theatre during a concert it could be at the very least annoying and embarrassing. For integrated building control systems that combine lighting with climate control, security door access and fire warning systems, wireless is not suitable except at the lowest possible security levels.

The susceptibility to interference arises from the basic framework of the transmission protocols. The CSMA approach on which all of these network protocols are based relies on checks if there is an idle transmission channel before transmitting the information. This collision avoidance is required because many other devices share the same frequency bands. For example, WiFi, Bluetooth and ZigBee all use the same frequency. In practice, this means that if you're downloading something on your notebook or streaming films onto your tablet, you're using WiFi with a high data usage where the node transmits each data packet in its entirety, thus breaking the 1% duty cycle rule.

If meanwhile another device wants to use the channel, for example, to switch on the light, the actuator switch has to wait for an open slot where no other device is using the frequency (Figure 4).

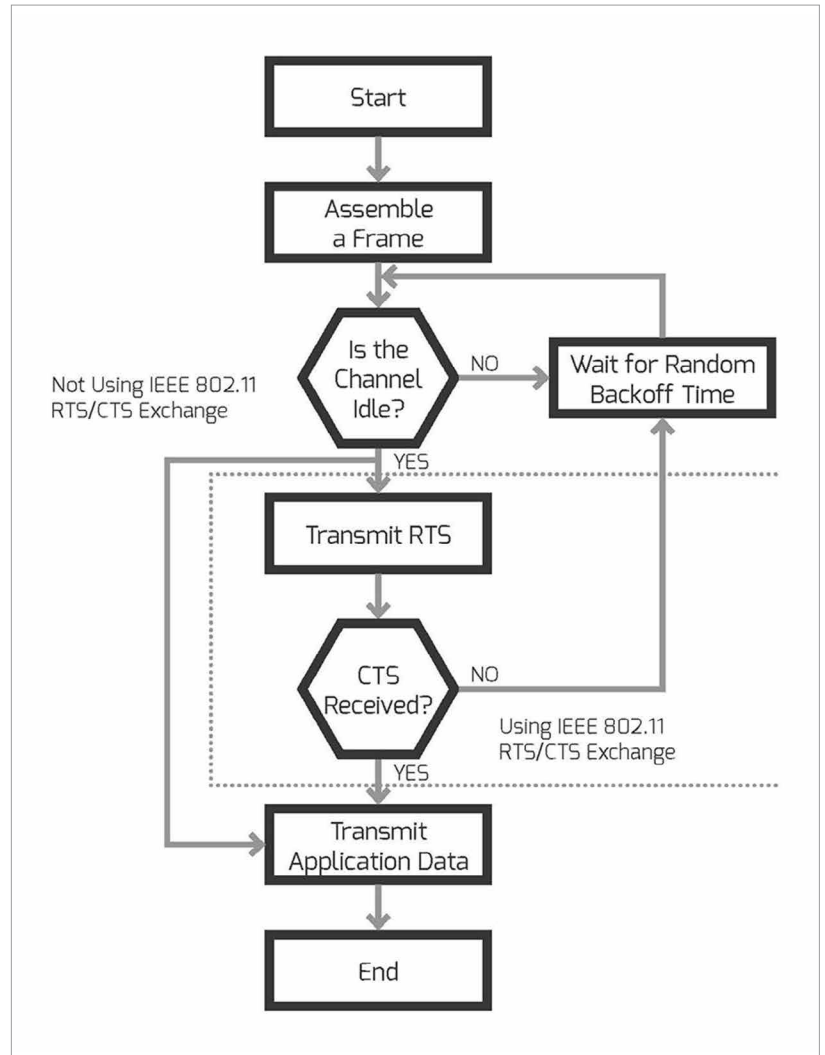

This delay may take from milliseconds up to seconds before the lighting network can steal away an empty slot from the WiFi network.

The effect on the user is maybe the film they are watching stalls each time the light switch is activated. The reverse effect on the lighting circuit is that it also appears to stall or drop commands. The user may start to lose confidence in the lighting system and complain that it is unreliable or erratic.

The problem is exacerbated with energy harvesting wireless switches that use the mechanical energy of the button press to generate power. The energy generated is small, so each press will typically allow the command to be sent only three times before the stored energy dissipates away.

A solution would be to use different frequencies to transmit different wireless networks, but only limited

bandwidths have been released as license-free and it is much more likely that bandwidth sharing will occur than not, especially with the concept of the Internet -of-things where hundreds of devices may be competing for time slots.

Therefore, the answer to the question, which system to use depends strongly on the application, existing infrastructure and desired security level. If the location is an open architecture with few metal or concrete structures or if the installation has to be retrofitted in a historic building, a wireless system is most likely the best choice. In a new building with steel-reinforced concrete walls and floors, a wireless network may face a lot of troubles with reflections, absorptions and losses through the building structure. In this case a wired system is more reliable. There is also the possibility of using a mixed system in an area where there are a lot of large



CREE® IS LED LIGHTING

versatile LED light.

As the developer of the first lighting-class LED, we're not scrambling to adapt to change; we are the change—and we won't stop until LED lighting is everywhere. Design in Cree LED modules and get one consistent light source with a choice of Sunset or WhiteLight dimming for applications ranging from intimate nooks to soaring atriums.

Cree makes light for living.



CREE LMH2 MODULES ARE BACKED BY 3RD-PARTY DRIVER COMPATIBILITY TESTING AND A 5-YEAR WARRANTY.



Visit cree.com/modules and learn how our full portfolio of LED modules can lower your system cost.

rooms like universities and museums by using a wired backbone linking up local wireless networks. Also a mixed system can combine the benefits of the flexibility of stochastic networks with the security and reliability of deterministic networks.

The Application

Intelligent lighting gives light architects and designers more degrees of freedom to build new solutions for offices, show rooms, museums and theatres.

For example, a showroom has the task to display the best side of a product or artwork to the public, but the light levels are very dependent on the weather outside. On a sunny day the light mood is different to the mood on a rainy day, not just due to the absolute light levels but also due to the quality of the light but also due to the albedo of the object to be displayed. An intelligent (sensor driven) lighting system can use indoor and outdoor sensors to detect the light level, color temperature and light diffusion levels and report this to the lighting system. The lighting system can then be programmed to react to adapt the lighting within the room to always present the object on display with the optimum color rendering, light intensity and minimum energy consumption.

The same applies for museums or art galleries, but with the added complication that the system must also provide ambient lighting that is restful and pleasant for the visitors as well as adequately lighting the objects and artworks without either causing visitor disorientation due to sudden changes in light levels or damaging sensitive artworks with high UV levels. According to the information that the sensors report to the system, the lighting system can react and adjust brightness and color temperature in each exhibition space individually depending on the occupancy levels. This level of autonomy is not new, but the ability of LED lighting to project light with variable color temperatures and to dim without affecting the color

rendering index, added to the rapid reduction in the cost of such systems, has enabled new applications in areas where it was not possible before due to technological or financial reasons.

The LED Driver

The utopian scenarios described above require a new way of thinking in the development of LED drivers. In the past (and still often nowadays) there is a very simple way of thinking about LED drivers, namely, a different LED driver is required for each application depending on the light engine. This thinking was correct, or at least acceptable, in the past but does not hold for the future of intelligent lighting systems, where many different kinds of LED luminaires, spots, wall washers, direct and indirect lighting may need to be integrated into a single network or network of networks.

The diversity of options that may have to be integrated into an LED driver in the future has necessarily led to a new way of thinking. This new thinking is necessary because the LED driver market is a very price sensitive one and all these shiny new extras come at a price – especially when there is the need to develop a new LED driver for every application or light source within an application. If there is a new development for every application or light source, the lighting designer comes very quickly into a high mix and low volume portfolio and with such combinations the prices per LED driver rise and at some point they become unaffordable. To address this topic there has to be a universal platform design at a reasonable price.

Due to the complexity that new applications bring, it is necessary to separate the complete design problem into smaller, more manageable parts. The first element to consider is the AC/DC ballast. The traditional solution is a 115 VAC or 230 VAC input voltage power supply with fixed output current. For example, a 25 W LED driver might be specified with an output current of 500 mA that is constant over an output voltage range of 36 VDC – 48 VDC (18-24 W). If the LED forward voltage is

below 36 V, the LED driver will not be able to drive the LED properly. Even if the undimmed forward voltage is within range, say, at 40 V, this forward voltage will drop with decreased current so that the output current can become unstable at low dimming levels unless a PWM dimming scheme is used with the corresponding risk of a stroboscope effect.

A more flexible solution is a universal input AC/DC supply feeding a freely programmable DC/DC output stage. The constant current voltage range can then be as wide as 6 V – 40 V, so all LEDs in the range of 3 W to 20 W can be properly driven at a wide range of pre-set drive currents. Thus the lighting designer can think in terms of LED power (10 W, 20 W, 40 W) and not worry too much about amps and volts.

This two-stage solution has, like every technical approach, advantages and disadvantages. The disadvantages are that the solution is more complicated and therefore more expensive and that there are more internal losses because of the extra output stage. A DC/DC stage normally has an efficiency of more than 92%, so there are not large additional losses, but there are some. This disadvantage is largely outweighed by the advantage that the LED ballast can realize a dimming range from 0 to 100% in almost every output current range that the customer wants within the maximum output voltage limit. The fact that one power supply can be used with many different LED light engines and luminaires moves away from the high mix, low volume area towards the low mix, high volume area, with a corresponding improvement in costs, lead times and installation simplicity. By adding digital or analogue dimming to this universal solution a truly intelligent lighting network comes a step closer.

One of the main advantages of LED lighting over traditional lighting is the efficacy, or lumens per watt, and the long lumen maintenance lifetime, or LM80 figures. But it makes little sense to have a highly efficient light engine with low lumen depreciation if the LED driver is inefficient or unreliable.

Many early uptake LED lighting installers suffered from premature failing lighting systems until it was understood that the thermal design of both the LED light engine and LED driver are critical in determining the useful lifetime of the fixture. In the meantime, most LED luminaire manufacturers have learned the basics of good thermal design with adequate heat-sinking, good choice of TEM materials and careful passive or active cooling.

The real-life thermal performance of the LED driver is, however, much harder to determine by just looking at the datasheet figures alone. Essentially, the efficiency under the actual operating conditions is more important than the operating temperature range on the label. The efficiency will be typically given at full load (maximum output voltage) but may be very different in other parts of the operating curve or when dimmed below 100%. The additional advantage of a DC/DC output stage is that it maintains a stable efficiency over a wide range of operating conditions and dimming levels.

All LED power supplies with a power of more than 25 W need a power factor correction (PFC) circuit. For the primary side, there are two topologies that are commonly implemented. The first is to use the transformer primary winding also as the active PFC inductor to reduce size and cost. This single stage topology is simple but it needs very big output capacitors to eliminate the resultant 100 Hz output ripple. The output capacitors have to be electrolytic capacitors to get a high enough capacitance and this limits the lifetime of the driver because the high output ripple current increases the internal temperatures and they suffer from aging effects. The alternative topology is to use a two-stage solution with a separate boost inductor that does not need the big output capacitors because the high frequency PFC circuit can store energy in a small capacitor at the output of the boost stage. The boost converter PFC stage runs at typically 50 kHz compared to the 100 Hz single stage PFC solution. What implication has this for intelligent lighting? Well, most PFC circuits, whether single or dual stage designs, use analogue controllers. A fully digital PFC controller has more flexibility to adjust to different operating conditions and input voltages to generate a power factor closer to 1 with a corresponding reduction in the THD value (Table 1).

Input Voltage (VAC)	Power Factor	THD (%)
90	0.999	0.1%
115	0.998	0.4%
230	0.992	1.6%
264	0.984	3.0%
277	0.981	4.0%
305	0.972	5.5%

Table 1: Measured Power Factor and THD values with Digital PFC (60 W LED driver)

In addition, if the PFC controller is digital and intelligent, then it is not difficult to integrate a PLC transceiver into the design to enable power line communication. The use of a digital PFC controller is another step closer to the realization of an intelligent lighting network.

The DC/DC stage can be realized in many different topologies as well. The most common topologies are buck, boost and buck-boost because they are a second order systems and easy to control. Which topology is the best for the design depends on which voltage ranges the LED light engines require. Independently from the choice of topology, there are still some things that have to be considered. These considerations are all about efficiency and price. A good estimation is that the more efficiency needed, the more expensive it gets. In practice it is always a trade-off.

Last but not least is the consideration of how the DC/DC stage is driven or controlled. To meet the requirements for the applications discussed above, it is necessary to have a digital control circuit in the design. The last few years have shown a vast increase in the microcontroller market because of the widespread introduction of the ARM cortex and the IoT hype. This development is also very useful for the lighting segment as the cost of an integrated microcontroller incorporating core independent peripherals such as fast comparators, rail-to-rail op-amps and high resolution PWM generators has dropped to below the cost of an equivalent analogue controller solution with all of its associated components. This development is the final jigsaw piece in the intelligent lighting concept. In figure 5 the principle of such a LED driver is shown.



BEYOND SAFETY

UL SERVICES AND EXPERTISE BRING NEW OPPORTUNITIES TO LIGHT

- Obtain Safety, Energy Efficiency, Performance Certifications and more
- Access Global Markets
- Leverage Industry Expertise and Standards Development
- Get a Type C Goniophotometer for Your Lab

DISCOVER MORE AT
UL.COM/LIGHTING

VISIT US AT LPS
STAND A12



Figure 5:
Principle of an LED driver topology with a three stage design. In a two stage design the APFC and the transformer are combined

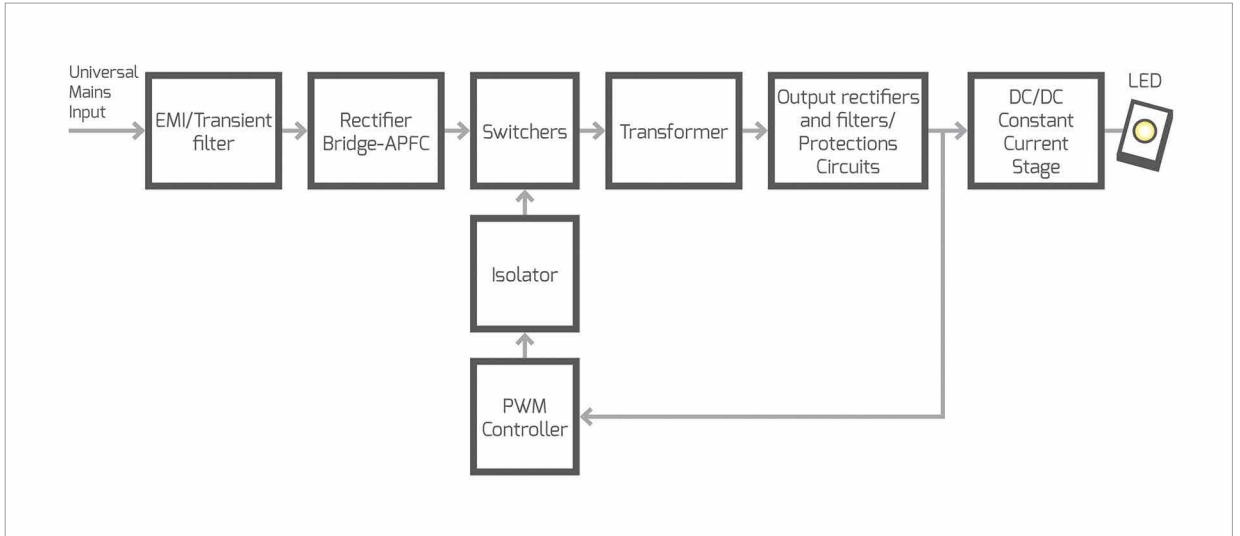

It showed to be the most promising solution to go for a digital solution that leaves the degree of freedom as open as possible during the design process for a new LED driver. In each power supply there are three digital controllers. The high side digital PFC controller achieves industry leading power factor correction with ultra-low THD levels over the full input voltage range of 90-305Vac. A low-side microcontroller is used to control the LED string currents and a second microcontroller is used to handle the communication within the network of the application where the LED driver will be used. The communication between the two microcontrollers is realized with I2C standard commands.

The I2C bus system is a well-established and robust internal communication bus. Furthermore, this bus system is implemented in very small 8bit microcontrollers and also in larger, more complex 32bit ones. This means a very lightweight bus system can be implemented on an 8bit microcontroller but the solution is also suitable to carry an ARM Cortex processor with some kind of embedded Linux to handle more complicated tasks. This platform design leaves it completely open to lighting architects and designers to request firmware or communication updates to easily integrate the LED driver within the intelligent lighting network.

Conclusion

An intelligent lighting concept requires several elements to be fully realized; a wired or wireless or hybrid communication network (with or without a central controller), a wide range of sensors, switches and detectors that can seamlessly communicate with each other and intelligent LED drivers that incorporate digitally-controlled power stages to drive a wide range of light engines with high accuracy, reliability and control resolution. ■



THE INDUSTRY'S FIRST 8000 LUMEN LED MODULE

Cree's LMH2 LED Module family is the only light source that can address a wide range of lighting applications in a common form factor, enabling lighting manufacturers to quickly develop an entire product portfolio with just one set of tooling and optical design. The LMH2 LED Module family is now available in 850 to 8000 lumens, color temperatures of 2700 K to 4000 K and no-compromise sunset dimming, delivering high efficacy and high CRI from a small 61 mm light-emitting surface (LES).

Please visit www.cree.com/modules to learn more.

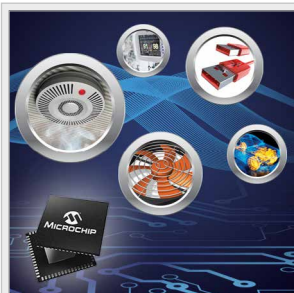

Analog is Everywhere

- Power Management
- Interface
- Safety and Security
- Thermal Management
- Signal Conditioning
- LED Lighting



LED



HIGH-PERFORMANCE ALL PURPOSE LED DRIVER

- RACD100/RACD150 SERIES
- UNIVERSAL AC INPUT (INCL. 277VAC)
- CONSTANT CURRENT/ CONSTANT VOLTAGE
- OUTPUT VOLTAGE UP TO 48V
- MAX OUTPUT CURRENT UP TO 11A
- 90% EFFICIENCY POWERED BY NXP TECHNOLOGY
- UV-RESISTANT METAL CASE (IP67)
- UL8750 / ENEC / PSE CERTIFIED

WWW.RECOM-LIGHTING.COM

DRIVERS

RECOM
LIGHTING

Lighting & Building Automation Technologies

The transition from traditional lighting technology to LED is old news. People in the lighting business no longer talk about the “LED Revolution”. Today’s revolution, perhaps spurred on by LED technology, is in building automation and lighting controls. Lighting experts know that while LED products have the potential to achieve terawatts of power savings worldwide over the next decade, even larger power savings might be achieved through effective lighting control and building automation systems.

Greg Galluccio, Director at Leviton Manufacturing discusses lighting load-shedding strategies, such as daylight harvesting, occupancy sensing, task management and demand response as well as the trends towards the interaction of lighting control with other building functions.

Those of us who attended this year’s Light and Building show in Frankfurt, may have noticed that there were nearly three full pavilions of building automation solutions on display. Many of them were new companies as well as some large, established companies not traditionally associated with the Lighting industry taking large amounts of booth space at the show. So clearly, the building automation industry is rapidly growing.

Introduction

Commercial building owners can save an average of 15% on energy usage by implementing a full-function Building Automation System (BAS). By full-function, we are referring to systems that monitor and control all major functions including heating, ventilation and air conditioning (HVAC), lighting, security, access control, metering, IT and communications. Tying all these systems together and allowing information transfer from one system to the other to inform

automated control across all platforms is becoming the state-of-the-art. The benefits of this high level of control are enticing but the complicated maze of systems and protocols needed to do it is often too daunting for the building owner to understand.

At the top level you have the primary bus, sometimes referred to as the “backbone” bus. That bus usually requires a high-level, high-information density language to communicate between the human interface and the

Figure 1:
A typical BAS configuration for a medium size commercial building such as a small factory, school or office building. Note: There are several network communication levels, each with its own protocol or language

However, much like the LED market of 6 years ago, the controls market is now the “Wild, Wild West”. Multiple competing protocols exist (many of them proprietary), there is a lack of interoperability and standardization, and an over-proliferation of acronyms (DALI, KNX, BACnet, POE, etc.) assault the casual user. As is the case with any new market technology, various claims of capability and reliability are circulating, waiting to be proven in the marketplace. For the brave first-implementers, the savings can be considerable but so can the risks.

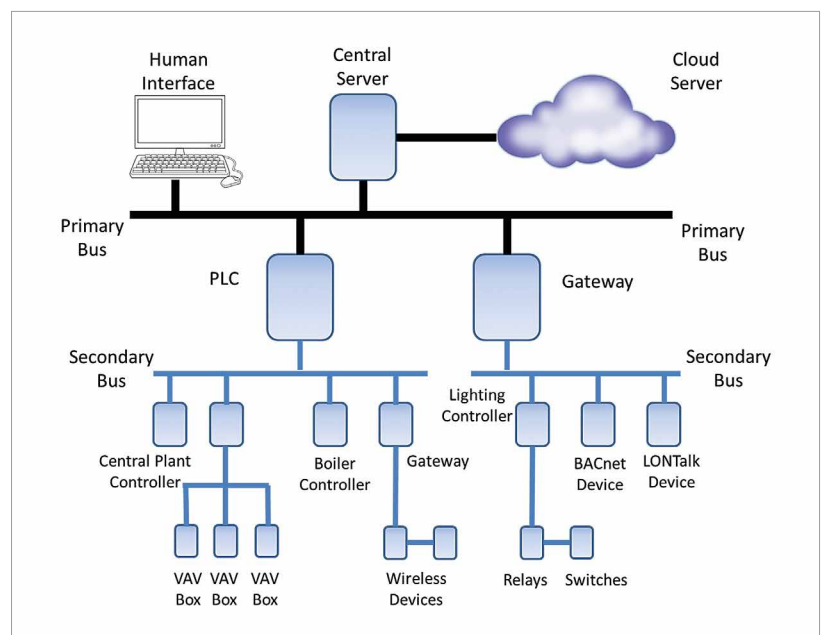

Figure 2:
Some logos of the most important BAS protocols. Each of these systems uses its own unique protocol

network of systems being controlled. Some examples of the more robust protocols would be BACnet, KNX or even a web-based IP protocol. Below that you have different systems being controlled by different, more product-specific protocols. You may have a lighting system controlled by KNX protocol, a metering system using M-bus and a security access/intrusion system using a proprietary security protocol from a specific manufacturer. Each of those systems consists of devices that hang on a secondary bus which is then routed to a controller module. The controller transmits and receives messages from the primary bus, and acts as a gateway/translation device that then transmits and receives commands and information to and from the attached devices in the secondary network.

Most levels and protocols are incapable of communicating with other levels or protocols without translation, which is why a primary or backbone bus is needed to carry translated messages back and forth to the user interface.

Naturally, these systems grew up when the industries worked independently and there was little impetus to interconnect, so the lower level languages are mostly industry-specific. Let's take a quick look at that.

Building Automation System Protocols

The alphabet soup of BAS protocols consists of systems such as BACnet, LON, KNX, MODBUS, EnOcean, DALI, TCP/IP, DMX512, ABB Ego-n, Excomfot, Open-therm, M-Bus, SMI and many others (Figure 2). The best way to understand these protocols is to see how they are categorized.

Proprietary or open

Systems are either proprietary or open depending on the choices of the manufacturer or controlling organization. Open systems are available for public use and sometimes modification but may require a licensing or royalty fee. BACnet, LON, KNX, EnOcean, DALI,

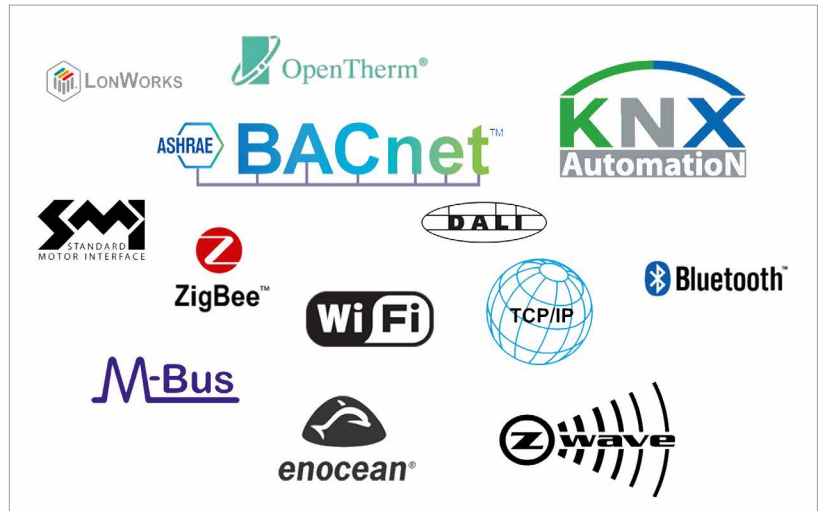

TCP/IP and OpenTherm are all open systems. Open systems are available for any manufacturer to implement, however they may require the payment of a royalty or usage fee. Proprietary or closed systems are usually restricted to the products of a single manufacturer, such as ABB Ego-n. The advantage of these proprietary systems is that they can be economically programmed to work efficiently and in many cases are most easily commissioned upon installation as all network devices are known to the system. The disadvantages are obvious – expansion of the system to include products beyond those of the system manufacturer may be difficult or impossible.

Complex or simple

Simple protocols, such as DALI and OpenTherm are designed for and limited to a single application. DALI, for example, is a lighting control protocol and cannot be used for HVAC control or other applications. OpenTherm was designed for heating and cooling applications only. SMI is limited to motor control (such as motorized window shades), and M-Bus is primarily a metering protocol. Complex protocols, such as BACnet, LON, KNX and TCP/IP are capable of higher level control and communication, and can be used for a wider range of applications. It will be discussed exactly what is meant by a higher level of control later in this article.

Topology

Networks can be connected into different types of connection topologies, but for simplicity we will consider them as being either centralized (as in a star network) and distributed (such as a mesh or ring network). In a centralized or star configuration, all network devices must connect to a centralized hub. The hub generally contains most or all of the intelligence and it controls the various devices connected to the sub-network. There is a cost advantage to centralizing most of the processing power, however this type of system is vulnerable to a failure of the hub unit that can result in the loss of operation of the entire sub-network. In a distributed system, each device has some intelligence and can connect and communicate with other devices in the system without a centralized hub connection. This configuration is far less vulnerable to centralized system failure, however it will likely be more expensive to build intelligence into all the peripheral devices. Some protocols such as DALI, can work in both central and distributed configurations.

Wireless protocols

Zigbee and Z-Wave are two protocols that were developed specifically for wireless applications. Z-Wave is a proprietary wireless RF-based communications technology designed for control and status reading applications in residential and light commercial environments. Target applications for Z-Wave are



Flexible

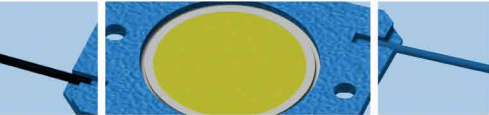

ADAPTABLE TO YOUR REQUIREMENTS

Our holder series 430, **Your** benefits:

- dynamic concept for flexible adaptation
- Micanite for temperature resistant connection
- welded contacts for low resistance and secure contact
- low profile for tight optics



The dynamic, tool-less concept of our series 430 allows an easy and fast adaptation to your requirements, even for small production quantities. Standardized mounting positions allow the installation of different COB modules on the same heat sink and optics.

Temperature resistant Micanite ensures a reliable connection between COB and heat sink and prevents premature LED-failure because of insufficient cooling.

The solder less connection of the wire creates a virtual resistance free electrical connection to the COB module.

The extreme low profile of the holder leaves plenty of space for the optics. Lenses and reflectors can be positioned extremely close to the actual LED and could be mounted directly onto the holder.

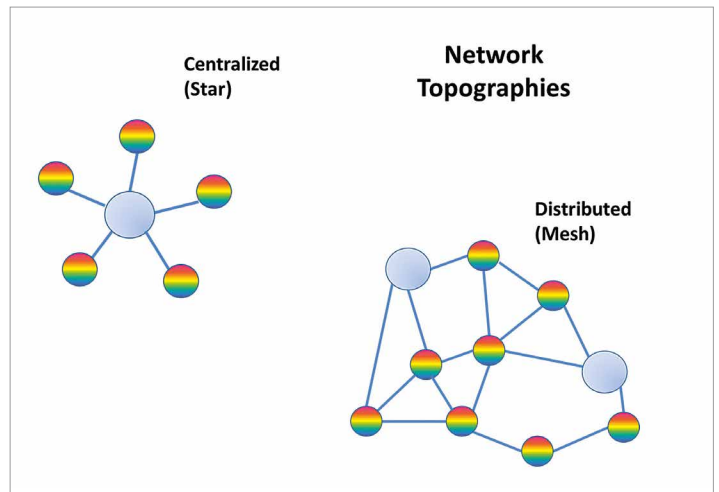

Figure 3: Star and mesh topologies are both very common in BAS

home entertainment, lighting and appliances control, HVAC systems and security. Similarly, ZigBee Home Automation offers a global standard for interoperable products, but is non-proprietary.

A full comparison of the two wireless solutions is beyond the scope of this article, however for various reasons, Z-Wave is more often used for commercial applications.

History

It all started in the boiler room. - The first building automation systems were HVAC controls. Specifically, building managers needed to have the building reach and hold temperature prior to the start of the work day, and turn off or adjust to a lower energy state at the appropriate time at the end of the day. A simple thermostat did not provide enough control to adequately regulate the operation of boilers and chillers – large, high-energy usage systems with slow state changes and lots of overshoot. Those systems needed to be fired up prior to the building occupancy period so they would have enough time to reach and maintain the appropriate ambient building temperature. Additional control intelligence beyond just on/off (such as feedback monitoring) was added to control temperature swings associated with thermostat operation.

Note that these systems did not need to convey large amounts of information, nor did they need to react quickly. The level of communication necessary to control HVAC loads could be kept somewhat simple and low cost. Very low baud rates could be used for busing information, and inexpensive chipsets could be used for processing simple commands. However, sending a series of multiple commands through this type of HVAC network might result in a system response time of several minutes. Not a problem for heating and cooling, but imagine if you sent a command through a controller to turn the lights on in an area and the lights came on 2 minutes later? Obviously lighting controls require a different solution.

New Requirements - Security Systems

When automated security systems came along, new levels of control were needed. Multiple camera systems, door and window sensors, remote-control door locks and other access controls, alarms and cameras were tied together and two-way communications were

centralized in security stations that allowed full-premises control from a single area. In this case, the system communications needed to be much more sophisticated, and they needed a high level of protection against hacking or tampering. The objects being controlled by these systems were not all simple on/off state devices. The controller needed to know what kind of device was connected – was it a camera transmitting images, a sensor monitoring open/closed, an alarm that dialed out to a monitoring service? The system needed the capability to set command priority levels. If an access point is instructed to be closed, but a fire alarm goes off, the fire alarm response system must be able to override the access control to allow people to enter or exit an area – thus fire alarm commands were given a higher priority level than access control commands, etc. The processors needed to know whether a failure of the control system should result in a device being left in the “off” state or the “on” state. For example, a control failure should leave all hallway, stairway and exit lights on, but should turn off systems that could become dangerous if they are not controlled, such as boilers or escalators.

The Last Missing Brick - Lighting

Until relatively recently, the lighting industry was the least “connected” from a full-building automation point of view. When energy was cheap, lighting control at the facility level was economically unsupportable in all but the largest installations. Dimming had esthetic and economic advantages, but there were barriers. Different types of lighting in the installed space required different types of control – incandescent lights used phase control (triac) dimming while fluorescent systems generally used 1-10 V controls to dim ballasts. Additional wiring often needed to be run to facilitate dimming control and fluorescent dimming ballasts were far more expensive than standard ballasts. As energy prices began to rise and energy efficiency became more of a trend, things started

to move but implementation tended to remain at the local or sub-system level. Occupancy sensors became popular, but usually were not networked at the facility level. Next came “daylight harvesting” in which ambient light levels are monitored with sensors, and interior lighting levels adjusted automatically in response to maintain a desired amount of light using the least amount of energy. These systems can be implemented at the local level also. However, facility managers are now interested in controlling the total amount of energy being delivered into lighting systems. Larger spaces such as parking lots and gymnasiums started being centrally connected and controlled through large dimming panels. Those panels were linked to the BAS via a high level protocol such as BACnet or KNX. Today, as dimming capability is being pushed out to the fixture level, large dimming panel type controllers are being replaced by small DIN-rail mounted controllers. Both light and heat can be further managed by giving the building control systems the ability to automatically raise and lower the window coverings.

Since many buildings are now moving to LED lighting as means of reducing their energy loads, it makes sense to add the controls while the new fixtures are being installed. Also, building codes are beginning to require occupancy, dimming and daylight harvesting controls for new installation.

Metering and Demand Response

Finally, knowing that you can’t really save what you don’t measure, one can now see the advent of intelligent sub-metering and demand response systems entering the market. Sub-metering allows the facilities manager to monitor and control energy usage at the sub-system level. Lighting circuits can be isolated from power outlet loads, and both can be metered and reported per floor, or even per room. Tenant energy billing can be automated and broken down to the individual tenant level. Machine loads can be monitored and

sequenced to avoid utility penalty charges for exceeding maximum peak power levels. Power factor problems can be identified and corrected saving thousands in energy costs. Sophisticated software products are available that can present energy data in multiple visual formats – graphs and charts can be generated, measurements can be provided at intervals down to the second and alarms can be set as prescribed by the user.

Demand response systems are automation controls that can be tied directly to the energy utility supplying power to the facility. Demand response control is intended to give the utility the capability of lowering energy usage by a small percentage across a large number of buildings, thus avoiding the possibility of rolling blackouts or brownouts due to excessive energy demands at peak periods.

New Technologies

Hundreds of new applications are on the horizon. Video based occupancy/vacancy sensors can now distinguish between human and non-human movement. Intelligent video systems can measure traffic patterns of people or vehicles. They can be used to assess the effectiveness of store displays or calculate usage rates for conference rooms, parking lots and other building spaces. Web services are being used to import HVAC and energy usage data into accounting systems for tenant billing purposes. Virtual thermostats can be used to give users control over their office environments. Overall building performance can be calculated and compared to similar buildings in an area and time frame to identify performance levels and possibilities for improvement. Other projects under consideration include using weather forecasts to optimize ice storage (chiller) systems. Universities are exploring the possibility of using their central classroom scheduling computer to automatically schedule HVAC, lighting and other classroom services. The possibilities are endless.

Figure 4: Different interfaces are available to control BAS. Apps for lighting controls, HVAC and many other tasks are available for smart phones and tablets using Android or iOS



The Chance for a Single Unified Standard

So why not use a high level, complex, multi-topology protocol, such as web services, for all of the many control applications? In other words, why not just control all lower level devices through a single, high-level bus using one unified protocol? Web services have become the standard for business to business communications, it seems reasonable to assume they could replace BACnet, KNX, and/or all of the sub-languages and protocols that currently exist, creating a single tier network configuration that uses a common language throughout.

This may not happen right away for several reasons. First, no one has developed a set of web services that covers all the functions needed by a BAS. Message prioritizing, synchronization, system backup and restore, broadcasts and alarms and so many other functions would need to be integrated. This can be done, but it would likely just become another BAS protocol fighting for acceptance in the marketplace. Its suitability could be called into question because web services require much more processing power than most BAS controllers can provide, so existing systems would need to be upgraded.

However, as processing power continues to become cheaper, and the incentive to connect back to utilities for smart grid applications and to outside entities for cross-comparison and data collection becomes stronger, TCP/IP or similar web based protocols may ultimately become the unifying factor. In the home, dimmers, sensors, surveillance cameras, thermostats, door locks and even lighting fixtures and appliances may all eventually become part of “the internet of things” with built-in intelligence and communication portals. In the meantime for commercial building applications, it is still most economical today to use lower level programming for the various sub-systems and connect them in an upwards configuration to BACnet and other complex protocol platforms for system integration.

This should all be familiar territory to the lighting expert. Just like in the LED markets with its non-standardized driver and dimming protocols, non-standardized component geometries, mounting and interconnection methods, the building automation industry is quickly being flooded with many new players all offering their own solutions. New technologies are

being introduced every year, costs are dropping, and no one really knows what the ultimate standardization platforms will be. Just as it is for LED lighting, the dilemma that faces the building owner is how to weigh the cost of not implementing an automation system against the risks of implementing a system that could become obsolete overnight, or have problems when it comes time to upgrade, expand or interconnect.

Conclusion

The takeaway for lighting designers is that control is the order of the day. Successful fixtures and lighting systems of the future will be those that are most easily configured for control protocol versatility, and with a minimum of setup or difficulty in commissioning. ■



Messe München
International

Connecting Global Competence

Welcome to Planet e.

The entire universe of electronics at a single location!

Tickets & Registration
www.electronica.de/en/tickets

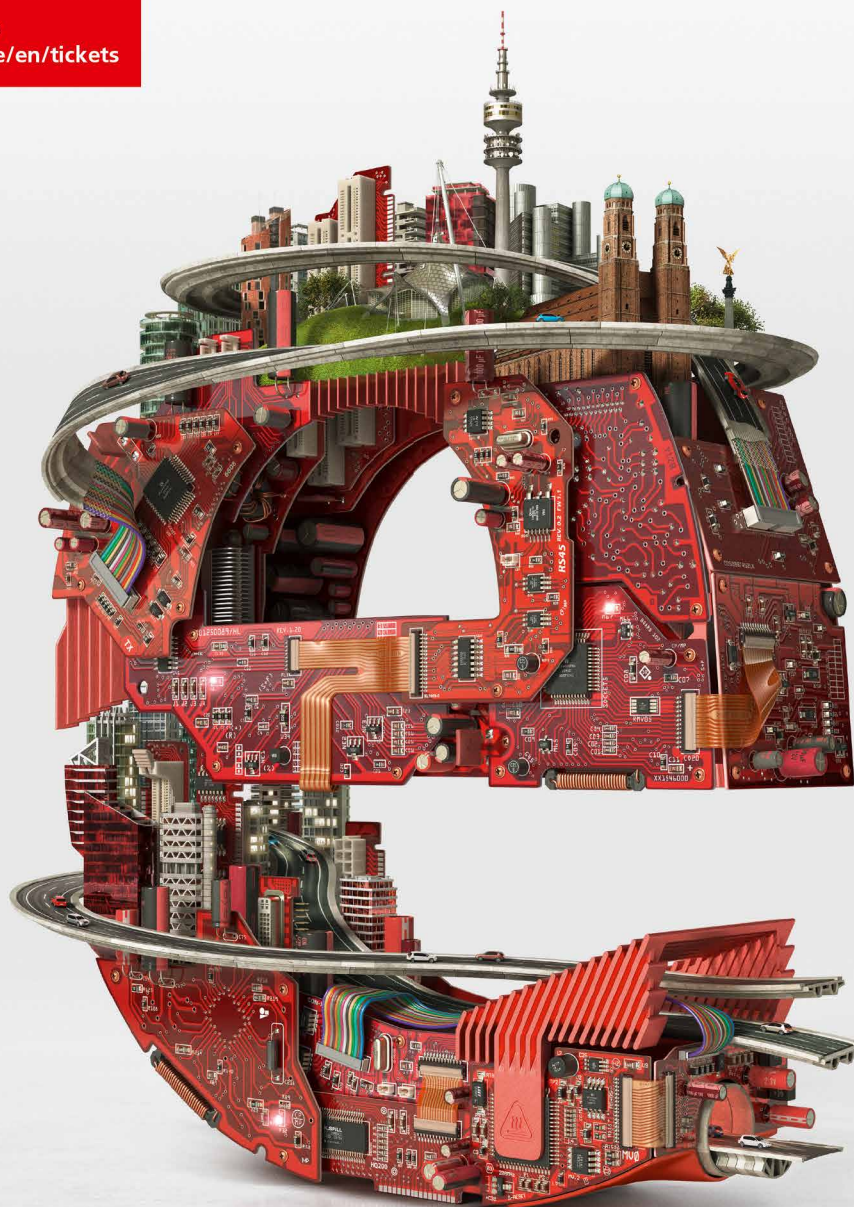

26th International Trade Fair for
Electronic Components, Systems
and Applications
Messe München
November 11–14, 2014
www.electronica.de

50 years
electronica



electronica 2014
inside tomorrow

The Status of Human Centric Lighting (HCL)

The spectral composition of light as well as its intensity is known to influence the human organism. It can stimulate or relax, which makes it relevant for our well-being. Human centric light has to take these facts into account. In most cases the goal is to emulate different daylight conditions and make them as lifelike as possible. Stefan Tasch from Lumitech and Guido Nattkemper from BAG electronics share their experiences from different fields like medicine, demonstrate what is possible today, and have a look at future trends.

Light decisively influences the well-being of people, characterizes their day and night time rhythm and effects activity and the ability to concentrate, as is generally known. Comparatively young however is research and development that attempts to utilize this health-promoting effect of light. “Human Centric Lighting” is the generic term for one of the most promising and high-growth segments in the lighting branch.

Here a focus is placed on people, their health and the influence of artificial lighting on the sense of well-being. The spectral composition of this artificial light as well as its intensity are oriented to the natural course of daylight, and simulate this to a high degree. These parameters significantly determine whether light has an activating or calming effect on the human organism. In the following talk, we offer an overview of the current state of the technology, report about specific practical experience within the various application areas, and demonstrate future trends as well as the latest research projects.

The Circadian System

During the process of evolution, the circadian system developed under the influence of the natural sequence of day and night (Figure 1). Daylight has a significant influence on physiological and psychological parameters. Consequently, the human eye contains not only rods and cones responsible for bright/dark vision and color vision, but also has so-called non-visual photoreceptors that have responsibility for influencing the human circadian rhythm. These receptors have maximum sensitivity in a wavelength range of approximately 450 nm. In modern societies however, people are distanced from natural sequences – we spend ever-more time in closed rooms bathed in artificial light, and many people make “the night to day” in a professional sense, without taking into account the rhythm of the circadian system.

A noticeable symptom of this is shortened or impaired sleep. Light with an increased blue component suppresses the evening discharge of the sleep-promoting hormone melatonin. On the other hand, light with high red components supports the discharge of melatonin, thereby contributing to relaxation.

Promoting Good Health

This is exactly where Human Centric Lighting has its effect – with the aim of providing support for the circadian rhythm of people. The human hormone balance has responsibility for this, especially the melatonin hormone, which determines our waking and sleeping behavior. To increase the discharge of this hormone, intelligent lighting systems feature various light spectra, and with differing intensities, depending on the time of day.

Figure 1:
Circadian rhythms

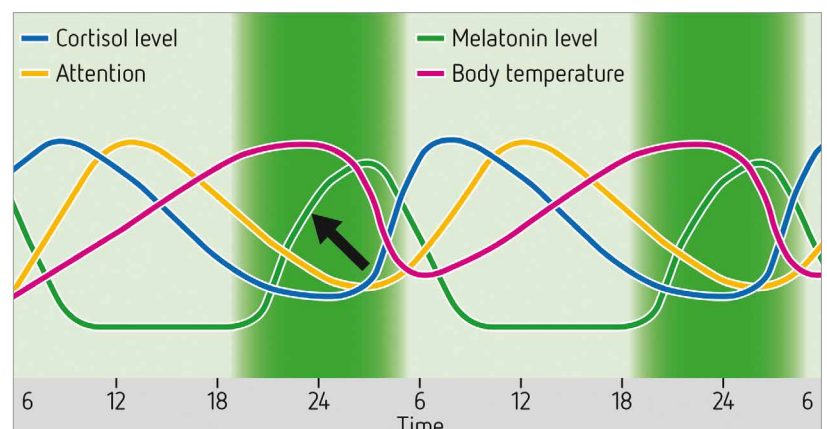

Figure 2:
CCT and color tunable lighting for HCL make rooms appear completely different. This allows for the rooms to be perfectly adapted to different tasks and/or moods



The following applies here: light sources with a warm light color, meaning with a low color temperature, have a lower circadian activation factor. The higher the blue component in the light source spectrum, the higher is the circadian activation factor and stimulation of the “blue receptors” that are responsible for controlling the biological functions. Positive effects can be achieved if this artificial light adapts to the natural human biological rhythm, by controlling the color temperatures and intensity.

Effectiveness

Various scientific surveys have demonstrated that sustainable effects are achievable with such controlled lighting systems – as a result, the error quotas of school pupils could be

reduced by more than 30 percent. The productivity of people at workstations was also partly increased by 20 percent in addition to improved motivation of these workers. Dipl.-Ing. R. Hetzel, Graz Technical University, stated: “The type and quality of artificial light sources and their effectiveness on comfort, well-being and health are being ever-more noticed and discussed (chronobiology). Following on from this is the requirement to simulate natural light (sunlight) as part of interior lighting.” [1]

In the year 2008, the PLACAR common research project demonstrated how brief exposition to light during the evening positively influences physiology and behaviour [2]. It was seen that the effectiveness manifested itself after only 10 minutes, and that the

effect increases with time if no adaptation occurs. The effect depends on light intensity, its direction and its spectral distribution. Based on these recognitions, systems have been developed and continuously optimized in past years, along with the advances of LEDs and especially technologies like the PI-LED system. The application areas for Human Centric Lighting (made possible and economically feasible thanks to LED) are exceedingly diverse and will become even more multifaceted in the coming years.

Medical Applications

Positive effects can also be achieved in the medical sector, as demonstrated by various pilot projects. A typical example is pre- and post-operative



Elegance, cooling with style
HEAT PIPE TECHNOLOGY

*Heat Sink for LED lamp
specific design for cob applications*

www.fratellipoli.it - www.ledheatsink.it

Via dei Fabbri, 26 - 36042 Breganze (VI) - ITALY - Tel. +39 0445 300 189 / +39 0445 873 304



situations where recovery processes can be supported by using controlled light and the consequent increase of melatonin discharge. A project carried out by the Charité Berlin concerning sleep research, clinical chronobiology and optimized lighting in care homes where residents suffer from dementia achieved highly interesting results [3]: "Night-time confusion is a primary reason for enrolling patients with Alzheimer's dementia in care homes. The increasing occurrence of nightly agitation is caused among other factors by a weakened circadian system. Exposure to daylight is reduced particularly with a weakened bodily constitution, and artificial light used in care homes often has insufficient illuminance levels and a low blue component."

The survey carried out in a care home for dementia patients analyzed how optimized lighting is able to achieve positive effects. A luminaire from TRILUX was installed in one of the care home's relaxation rooms, where residents spend a large part of their day. It was seen that the state of agitation and restlessness was significantly less after just one month. To determine this, the Cohen Mansfield Agitation Index (CMAI) was measured two weeks before and four weeks after the installation. This agitation index

measures the occurrence of agitated behavior related to the previous 14 days. The total score of the index significantly reduced with the test persons.

The common research project is also highly promising that was initiated in mid-2014: According to the principle of "optimized light systems for improving performance and health" (abbreviated to OLIVE in German), the options of intelligent lighting will be analyzed, ranging from energy saving to the promotion of health. The OLIVE joint project is intended to research the technological and bio-medical fundamentals for such intelligent lighting, and display the new light as part of various everyday situations and possibilities. The North Rhine Westphalia light forum will then evaluate the intelligent light within various application scenarios. The project is planned for a period of three years, up until mid-2017.

Perspectives

Scientifically founded, Human Centric Lighting enables many applications today, for example in the medical sector, in care homes and other commercial areas such as offices, retail and education. As result, it is already possible today to support the natural biological rhythm at the

workplace with color temperature daylight sequences – ranging from a stimulating effect in the morning to a more relaxed lunch period, and including phases of concentration in the afternoon and a soft transition to going home in the evening. Future focus applications are for example manufacturing companies with multiple shifts, whereby optimized lighting systems are able to improve the sense of well-being and ability to concentrate for such shift workers – and with positive effects for work safety among other factors. Simultaneously, it is of course also necessary that the relevant standards and directives for workstation lighting continue to be updated while taking into account such recognitions.

Different Levels of HCL

Already today, complete solutions are available from a single source that meet a wide diversity of needs (Figure 3). Premium solutions enable daylight to be precisely simulated according to the Planckian Curve, and with a daylight-similar quality of light ($R_a > 90$). In this case, the complete system of PI-LED, module, LMU and control units covers all construction forms (spot, area, planar and linear) with these having only exceedingly low color differences to each other ($MacAdams < 3$).

Figure 3:
Example of a complete portfolio to serve any level of Human Centric Lighting

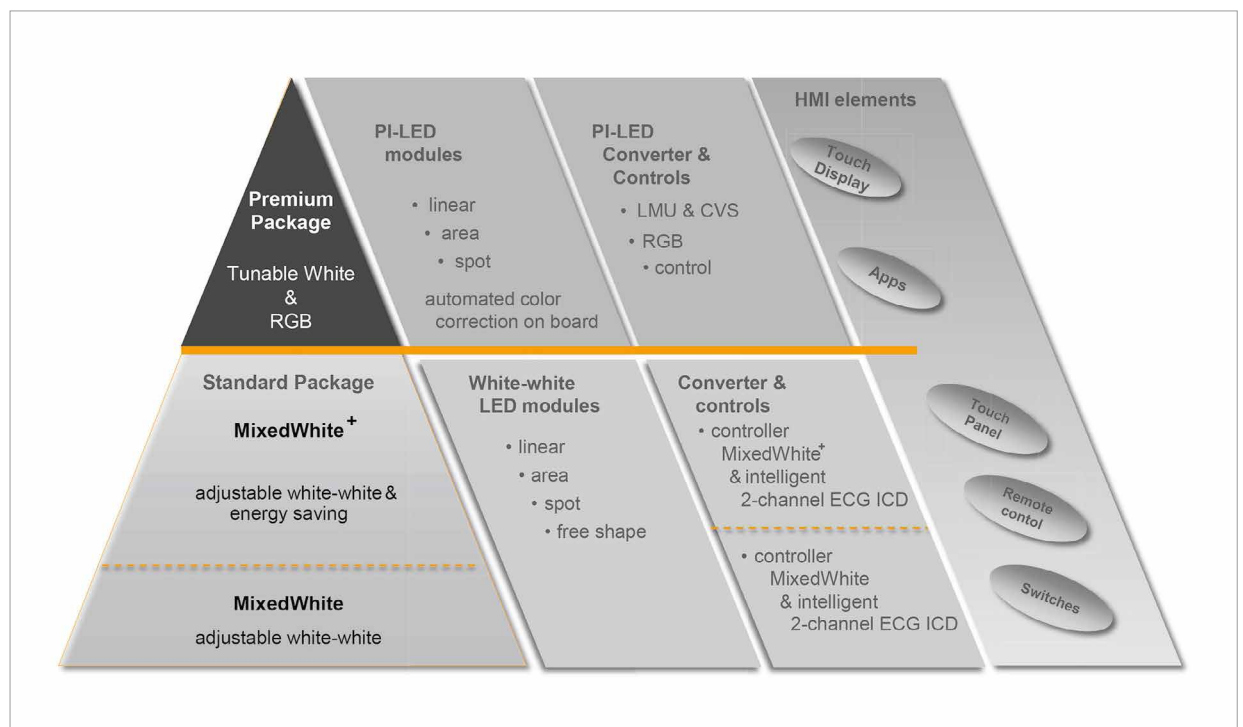

KOSIGN 2014

The 22nd Korea International Sign & Design Show

November 5(Wed) - 8(Sat), 2014

Coex Halls A&B, Seoul, Korea

»» National Pavilion Package Benefits

Coex offers unified booth designs, fee discounts, biz-matching arrangement and airfare discounts for National Pavilion Participants. If you would like to join, please contact us!

- Booth design upgrade
- One seminar room provided upon request
- Hotel & city tour arrangement assistance
- Booth fee discounts
- Free opportunities of advertisement
- Translation services

Booth Fee Information

Category	Space-only	Schell-scheme
Early-bird Registration (Deadline: 4 July 2014)	USD 2,800	USD 3,200
General Registration (Deadline: 3 October 2014)	USD 3,000	USD 3,400

Concurrent Events

- 1) Biz-matching Program
- 2) Korea Sign Design Awards 2014
- 3) Sign Scape 2014 UCC & Story

Organizers

coex



KODIPA

Sponsor

DGI

KOSIGN 2014 Secretariat

T. +82-2-6000-8126

F. +82-2-6944-8303

E. kosign.info@coex.co.kr

H. www.kosign.info

CHINA INTERNATIONAL OPTOELECTRONIC EXPO 2014

September 2-5

Shenzhen Convention & Exhibition Center
Shenzhen, China



LED Techna

A 360° View of the LED Industry

Materials & Components / Packaging & Modules
Lighting & Display / Manufacturing & Testing Equipments

YOUR ACCESS TO CHINA'S
OPTOELECTRONICS MARKET

please visit

WWW.CIOE.CN

CHINA INTERNATIONAL OPTOELECTRONIC EXPO ORGANIZING COMMITTEE

Add: Room 607, East Block, Coastal Building, Haide 3rd Road,
Nanshan District, Shenzhen, Guangdong, 518054, China

Tel: +86 755 8629 0891 Fax: +86 755 8629 0951

E-mail: international@cioe.cn

The precise setting of color temperature ranging from 2,500 K to 7,000 K complies with maximum demands for quality and precision, and can be implemented automatically according to time or modified manually or via sensor control. There is also the option of using the RGB color space in addition to white tones for daytime sequences, enabling specific light moods to be achieved. The premium system offers extremely wide flexibility in terms of control options as well: ranging from wired solutions to radio technology (wireless with ZigBee) that are often a feature in the modernization sector, all options are open.

Simpler systems, like the so-called MixedWhite system, consist of highly efficient warm white and cool white LEDs to enable economic Human Centric Lighting solutions. Color temperature and brightness are manually controlled with a push-button

according to the room situation. Two independently controllable output channels enable the economic implementation. The system also provides maximum flexibility because the LED modules used can be freely specified. More advanced solutions, like the MixedWhite+ solution, additionally provide the option of an integrated clock that enables the programming of individual key characteristics for the daylight-dependent, automatic modification of color temperature in compliance with our circadian rhythm. Even higher energy efficiency is achieved with daylight-dependent control in combination with presence detection. System control is convenient via remote control, touch panel or "combi"-sensor.

In the end though, it is the users along with the specific application areas that decide which technological version is

used to achieve Human Centric Lighting. Some applications, such as industrial lighting applications, are predestined for simple, white-white solutions according to cost-benefit analyses. In other areas, for example medical applications, maximum precision is needed for coordinating the light spectrum in the form of high-end systems. The market already offers solutions in this bandwidth that are mature for application.

Conclusions

Today's lighting standards are operationally safe, energy-efficient and with high performance, but do not represent the optimum when people are focused on with their physiological and psychological needs. Human Centric Lighting is an essential basis in this respect that will determine and change the lighting world in coming years. ■

References:

- [1] Tunable Natural Light Realized by Phosphor-Innovation Light-Emitting-Diode Technology, Reinhold Hetzel, Stefan Tasch & Günther Leising, Springer Verlag Vienna 2012
- [2] PLACAR Summary Report, Horst Rudolph, Arnsberg 2009
- [3] Optimised lighting reduces agitated behaviour of care home residents suffering from dementia, Wahnschaffe A, Nowozin C, Haedel S, Rudolph H, Rath A, Kunz D., Berlin 2008



High Voltage LED Chip (Blue/Red)

EPISTAR HV chips accomplish a revolutionary chip technology with metal interconnection between cells. This advanced technology provides our customer design flexibility and lower driver cost.

Features:

Better reliability / Lower driver cost / Higher lm/W / Better current spreading

Product Types:

Red HA40 (20V) / Blue FD20A (12V) FD17A (15V) FA20A (24V) FV60B (50V)

EPISTAR
sales@epistar.com.tw



Putting LEDs in the Right Light

SSL solutions from the world leader in LED measurement.

➤ Spectroradiometers

Unprecedented photometric and colorimetric accuracy

➤ Goniophotometers

Three models for different sample sizes

➤ Integrating Spheres

Ranging from 25 cm to 2 m in diameter

➤ Imaging Photometers and Colorimeters

Homogeneity of extended sources and OLEDs

Instrument Systems
light measurement
www.instrumentsystems.com



Rippled lens and module

TIR lens

Round lens clear



Lens array

Clear lens and module

4x4 Lens Array

Get in contact!
@Bregenz, LpS

30.09. - 02.10. Booth D7

Standard and custom optics for you!

fresnel, diffractive, lenses, dif-
fuse, silicone, individual, as-
pheric, cylindrical, prototypes,

led-optics, strainless, arrays,
spheric, plastic optics, design,
production & development

www.imos-gubela.de
info@imos-gubela.de

Professional Power

Buy 1 – get 3 free!

Innovative 120W/4-Channel power source PSU-0154-02
with patented SCICOR™ technology

- ▶ Replaces four 30 W standard LED Driver
- ▶ No inrush
- ▶ Up to 3,5 kW on one Phase
- ▶ High efficiency
- ▶ Reduce cable clutter
- ▶ 80.000 h Lifetime



Please come and visit us at the LED Symposium fair in Bregenz.

best partner @ LED business inpotron GmbH / excitron GmbH

LpS 2014
LED SYMPOSIUM
+ EXPO

inPOTRON™

Schaltnetzteile
Switch Mode Power Supplies

inpotron Schaltnetzteile GmbH
Hebelsteinstraße 5
78247 Hilzingen, Germany
Phone +49 7731 9757-0
E-Mail sales@inpotron.com
Internet www.inpotron.com

Tuneable Solid-State Lighting to Improve Light Quality

In the hospitality sector, the ability to reproduce natural light and halogen dimming characteristics is paramount. Uwe Thomas of LED Engin explains how that can be achieved, what the latest approaches are that made this possible, and how accurate state-of-the-art products are.

White light, as we humans see it is a mix of red, green and blue, called the tristimulus values, corresponding to the band pass filtered chromaticity response of cones in the retina. Back in 1931, the International Commission on Illumination (CIE) created a 'color space' map, representing the human perception to any combination of these colors, according to our response to long (red), medium (green) and short (blue) wavelengths.

Color is further characterized by manufacturers using a binning system. David MacAdam created a map of ellipses representing the deviations of perceived color by humans. Color bins are defined by ANSI as parallelograms overlaying these ellipses on the CIE color map. The smaller the bin, the less color variation.

Thus LED white light generation requires an appropriate mix of colors to generate an emitter at a specific color point. However, there are many

different methods by which manufacturers achieve the color mix, each with advantages and disadvantages. There are broadly two production methods. The first uses a blue LED die combined with different color phosphor materials, usually yellow, but also red and amber, to convert monochromatic light to broad-spectrum white light. The second is to combine red, green and blue LEDs directly into a multichip module, called an RGB LED.

Figure 1: MacAdam ellipses for one of MacAdam's test participants, plotted on the CIE 1931 xy chromaticity diagram. The ellipses are ten times their actual size

More recently, the Color Correlated Temperature (CCT) scale was calculated, overlaying the color map, according to the spectral emissions of a simulated black body radiator – an object that generates light due to thermal energy – and plotted using Planck's Law. Essentially, the black body radiator curve starts in deep red, rising through orange, yellow, white and eventually, a blue-white in the center. This area gives us shades of white, such that CCTs of 2700 K to 3000 K are described as warm white, 3500 K to 4000 K are neutral white, and 4500 K to 5500 K are cool white.

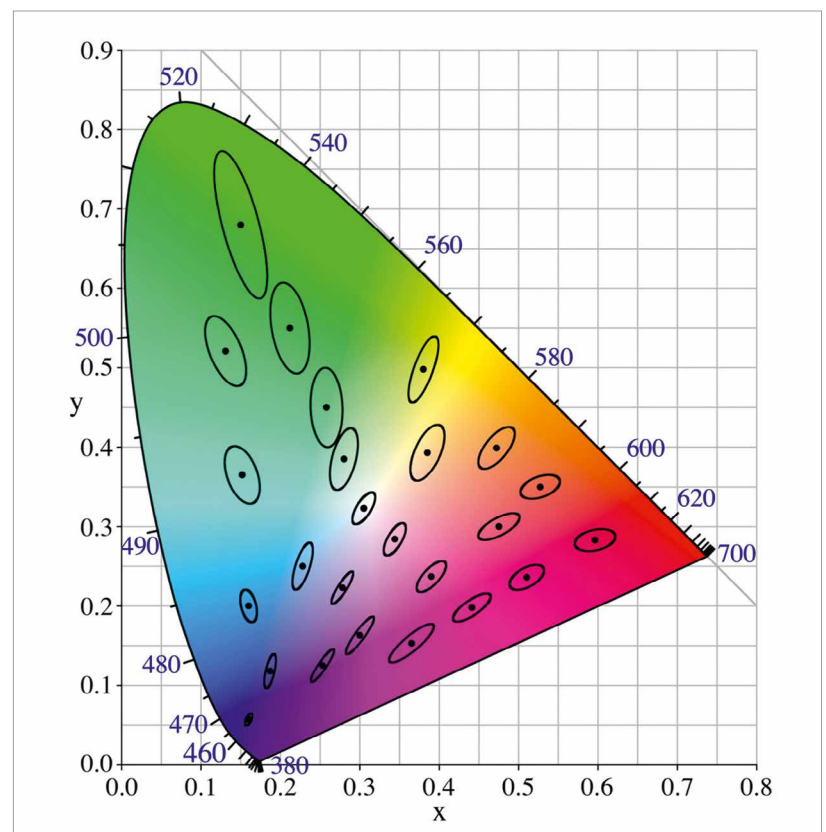

RGB LEDs tend to be more expensive, need a more complex driver, have only moderate color rendering properties and can leave colored shadows behind objects. However, manufacturers are beginning to overcome these problems, to give better control over color temperature and CRI. Color stability issues (red, blue and green LEDs have different aging characteristics) are also being successfully tackled with color sensors and feedback loop systems.

Phosphor for Color Stability

Phosphor conversion is the traditional and prevalent way to produce white light for most lighting applications. Shuji Nakamura is recognized as a leading developer of blue LEDs and lasers, and the method of growing GaN layers on sapphire substrates back in the 1990s. Blue diodes tend to be very stable with temperature variations, giving inherently better color stability. Thus with phosphor-converted LEDs, efficacy in terms of lumens/watt is better, and color temperature can be tuned by varying the phosphor/wavelength composition.

Within the gamut of phosphor-converted LEDs, there is a range of production methods. In addition to GaN on sapphire and GaN on silicon carbide substrates, GaN on GaN devices are emerging for ultra-high quality lighting applications. Although prices are falling, there remains a price premium on this technology.

LED manufacturers are continuing to develop phosphor processes to improve LED efficiency while optimizing light quality. A key production challenge has been to avoid variations in the thickness of phosphor layers, which can cause variations in both color temperature and hue. In terms of the phosphor recipe, the wavelength of the base LED die will make a difference to the end product, as does the number of layers, thickness of the layers, and colors of the phosphors.

Some manufacturers use UV as well as blue pumps, and three different color phosphors. By using multiple phosphor

layers of different colors, the emitted spectrum is broadened, effectively raising CRI. There is a risk that such devices may not be as energy efficient as conventional LEDs, however.

The method of applying the phosphors varies too. Early methods, still in use by some manufacturers, drop the phosphor paste into a cup-type blue LED. However, natural variations in materials and processes means the resulting devices cannot be closely matched to a color space, typically 2.0 ANSI bin distribution. The cup structure also gives rise to color over angle issues.

An evolution of this approach gives some marginal improvement. A phosphor layer is applied directly onto the blue die. Color uniformity is improved to around 1.5 ANSI bin distribution, color point over temperature is improved and the color over angle is better.

Remote phosphor is a new process, whereby the phosphor is not in direct contact with the die. The phosphor is formed with a substrate or secondary optic, typically incorporating a mixing chamber, and physically separating from the LED die or package. Advantages of this approach include reduced thermal impact, improved efficiency and efficacy, more uniform luminous intensity distribution, and spatial color uniformity. On the downside, the products tend to be more expensive, as patent licensing is an issue, and they have larger light emitting surfaces.

Meanwhile, developments with applying the phosphor layers onto die assembled in a chip on board (CoB) array has resulted in much tighter color uniformity, as high as 1/8 ANSI bin distribution. The method is also said to simplify the manufacturing process as a flip-chip assembly allows the die to be soldered directly to a substrate such as a metal core PCB. However, assembling these die into a CoB package can create larger light emitting surfaces.

Multi-Die Emitters

Alternatively, the phosphor can be printed directly onto the die, which are then assembled into multi-die emitters. This allows a direct thermal path to be created, helping the phosphor run cooler, and producing more consistent phosphor characteristics. Color consistency is better than 1/8 ANSI bin distribution (less than 3 MacAdams). Color over angle and color point stability over temperature characteristics are also superior.

Importantly, the bare die approach allows LEDs with different color points to be closely packed in arrays. This gives two major advantages. The first is that high-density packaging is essential for high flux output and a more compact end product, particularly if thermal management is effective. The second is that the ability to mix die from different color spaces is critical for color mixing and tuning applications. The latest, most advanced multi-die emitters and light engines use this method.

With the phosphor-on-die construction, thermal management is intrinsic to the design. A gold eutectic die-attach process, in place of using conventional adhesives, provides better thermal conductivity. A multilayer metal into ceramic substrate is the preferred solution to best match the device's coefficient of thermal expansion (CTE) and further reduce thermal stress. The device is mounted on an appropriately sized heat sink with superior surface flatness to minimize voids.

Light engines targeted at downlighting and accenting applications in the hospitality sector, require precise tuning in terms of lumen output and color temperature, to create the desired halogen-like dimming and ambience. Luminaires using LEDs need to be tuned to create this effect. With the phosphor-on-die multi-emitter approach, color mixing is best achieved using carefully matched secondary optics to optimize the lumens-on-target, and produce a smooth beam edge

Figure 2:
Exemplary cross-section of a high quality multi-die emitter (in this case a UV emitter)

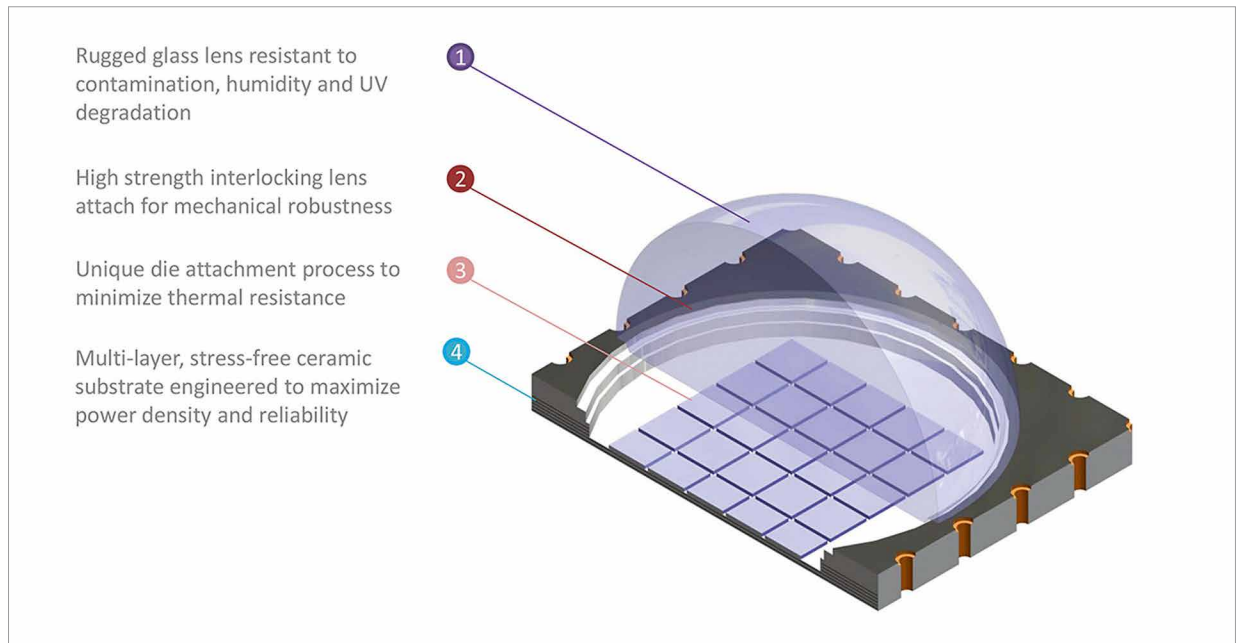

to minimize unwanted glare. A total internal reflection (TIR) design ensures consistent quality of light across the beam, irrespective of beam width, which can be from 24° to 45°.

The ability to mix LEDs with different CCTs in one package is fundamental to the color and hue tuning functions. With a multi-channel, multi-emitter design (12 die grouped into three channels, for example), the light can be triangulated using a sophisticated microcontroller running proprietary algorithms, to allow the color temperature to be varied. For halogen-style dimming, 3000 K down to 1800 K along the black body curve is required.

Tunable LED luminaires are increasingly in demand for 'human-centric' and 'wellness' lighting applications. Therefore a tuning

function that can be separately adjustable for CCTs between 4300 K and 2100 K is likely to be popular.

Importantly, the manufacturing processes and control electronics combine to ensure that the emitters produce a consistent color temperature within 3SDCM (standard deviation color matching) or MacAdam ellipses, meaning that fixtures throughout an installation will deliver the same performance.

A glass rather than silicone primary lens over a low index silicone layer has been shown to demonstrate high color stability at various temperatures. Look for a typical performance of a CRI of 90, at 3000K, and the red component, R9 of 80 CRI. Then, when the module is dimmed, average CRI should be in the region of 85, and R9 averaging 70, in order to accurately render warm colors.

Summary

In hospitality applications, the ability to replicate the light quality and dimming characteristics of halogen bulbs is an essential consideration in the replacement market. The key is a tunable solid-state lighting system that produces familiar warm white tones as lamps are dimmed, while retaining color-rendering qualities. Just as important is a system that maintains color stability and light output as temperature changes, and over the lifetime of the product. And it has to be delivered in a compact package.

This level of performance is a direct result of careful design and overcoming the challenges of process variations and thermal management. CCT tuning in a compact package gives lighting designers greater creative freedom in a wide range of hospitality applications. ■



The World Leading Spectroradiometer HAAS-2000/3000 HIGH ACCURACY ARRAY SPECTRORADIOMETER

Spectroradiometer is one of the basic and most important instruments for light measurement. EVERFINE HAAS-2000/3000 adopts the scientific-grade TE-cooling array detector and precise grating, as well as patent technologies, so as to realize the world leading specifications, and has been widely applied worldwide.

EVERFINE

www.everfine.net

ILLUMINOTRONICA 2014

The unique Italian event trade fair
dedicated to the world
of Solid State Lighting

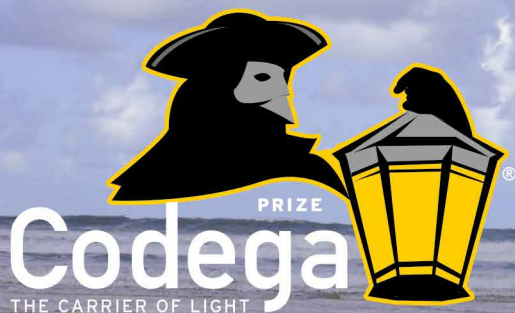

Save the date
9th/11th October
Padua - Italy

info:

www.illuminotronica.it



LED professional Review (LpR) - Annual Subscriptions

LpR Digital Magazine

- 6 issues
- pdf download
- high resolution pictures and graphs
- printable
- commercial use
- access to all previous issues
- Euro 78.80

LpR Printed Magazine

- 6 issues
- Euro 158.40

<http://www.led-professional.com/subscription>

Cover-page

Artwork: Thomas Klobassa,
©LED professional 2014

Main Image: Arno Grabher-Meyer,
LED professional

Product: GaN-on-Si technology

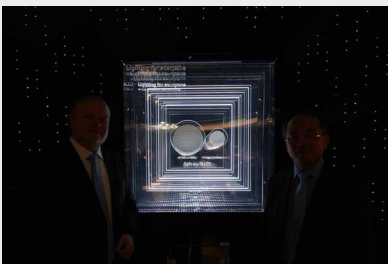

The "Technology Corner" at the Samsung booth at the Light + Building 2014 showed some future technologies like the transition from 4 inch to 8 inch silicon wafers for the GaN-on-Si LED production

Next LpR

Costs & Processes
Issue 46 - Nov/Dec 2014 -
Short Overview

LED Technology:

LED professional Scientific Award Winner Article

This year Luger Research will bestow the first Scientific Award to a University or Research Organization for the best submitted paper for the LED professional Symposium. The full paper will be published in this issue. ■

Events:

LED professional Symposium +Expo Post Show Report

An overview of newly released products launched at the LpS as well as other product highlights. Furthermore, there will be a summary of the best lectures. ■

Optics:

Development of a Workflow for Colored Ray Data

The importance of white LEDs has risen continuously over the past years. In many cases, disturbing color fringes appear on white LEDs with a blue chip and a yellow phosphor. To avoid this, different distribution of the blue and the yellow light has to be described for simulation. This means that colored ray files are necessary. A workflow and method for creating colored ray files is proposed and examined. ■

Manufacturing:

Managing Manufacturing and Supply Chain Challenges in LED Luminaire Design

Today's luminaires are complicated lighting systems that cause several common challenges that arise in LED manufacturing. The preferable way of mastering these challenges is to partner design and manufacturing firms to leverage technology and improve time to market. The article explains how to manage these design, manufacturing and supply chain challenges and gives a thermal management example. ■

Cost Saving Potential with Automation and Well Designed Processes

The manufacturing of modern LED luminaires and conventional fixtures has some similarities as well as some distinct differences that result in added challenges. Automation, in combination with a well-conceived product design and process and well-matched components, allows for economical manufacturing without compromising production quality. The technical challenges, successful concepts and solutions will be presented, explained and discussed. ■

subject to change

Imprint

LED professional Review (LpR), ISSN 1993-890X

Publishing Company

Luger Research e.U.

Institute for Innovation & Technology
Moosmahnstrasse 30
A 6850 Dornbirn, Austria / Europe
phone +43 5572 39 44 89
fax +43 5572 20 60 70
info@lugerresearch.com
www.lugerresearch.com

Publisher

Siegfried Luger +43 5572 39 44 89-70
s.luger@led-professional.com

Editor-in-Chief

Arno Grabher-Meyer +43 5572 39 44 89-18
a.g-m@led-professional.com

Research & Innovation Manager

Dr. Amrita Prasad +43 5572 39 44 89-19
amrita.prasad@led-professional.com

Int. Account Manager

Theresa Koenig +43 5572 39 44 89-20
theresa.koenig@led-professional.com

Marketing & Sales Manager

Katharina Fink +43 5572 39 44 89-43
katharina.fink@led-professional.com

Your Local Contacts

China, Hong-Kong

Iris Yuen +86 1380 27 01 367
irisyuen88@gmail.com

Germany

Armin Wezel +49 30 526 891 92
armin@eurokom-media.de

Japan

Eiji Yoshikawa +81 3 6751 0090
scala@s3.dion.ne.jp

South Korea

Jung Won Suh +82 2 78 58 222
sinsegi-2@sinsegimedia.info

Switzerland

Monika B. Ailinger +41 41 850 44 24
m.ailinger@marcomedia.ch

Taiwan

Leon Chen +886 2 256 81 786-10
leon@jkmmedia.com.tw

United Kingdom & France

Zena Coupé +44 1923 85 25 37
zena@expomedia.biz

US East

Karen C Smith-Kernc +1 717 397 7100
KarenKCS@aol.com

US West & Canada

Alan A. Kernc +1 717 397 7100
AlanKCS@aol.com

Copyrights - Luger Research e.U.

The editors make every reasonable effort to verify the information published, but Luger Research e.U. assumes no responsibility for the validity of any manufacturers, non profit organisations or individuals claims or statements.

Luger Research e.U. does not assume and hereby disclaims any liability to any person for any loss or damage caused by errors or omissions in the material contained herein, regardless of whether such errors result from negligence, accident or any other cause whatsoever. You may not copy, reproduce, republish, download, post, broadcast, transmit, make available to the public, or otherwise use LED professional Review (LpR) content without prior written consent from Luger Research e.U. – Institute for Innovation & Technology, Austria. ■



 **GET YOUR FREE E-MAGAZINE**
www.led-professional.com/free



The leading worldwide authority for
LED & OLED lighting technology information.

LEDs • OLEDs • Light Engines • Lighting Modules • Optics • Drivers • Thermal Management • Lamps • Fixtures • Production & Measurement Equipment Project Reports • Patent Reports • Research Reports • Event Reports

LED
professional

MORE THAN
21,500
READERS

www.led-professional.com

powered by Luger Research e.U.

Submit your article. Please contact Arno Grabher-Meyer, Editor in Chief, at a.g-m@led-professional.com

Small is Big



For Manual and
Automated Wiring Systems
2060



For Direct
Power System Feed-In
2061



For the
Smallest Sizes
2059

The Range of SMD Terminal Blocks

www.wago.com/SMD

The WAGO logo consists of the word "WAGO" in a bold, green, sans-serif font. The letter "W" is stylized with a green arrow pointing upwards and to the right, passing through the top of the letter. A registered trademark symbol (®) is located to the upper right of the "O".