



Research: Hybrid LEDs

Trends: Embedded Lighting

Technology: Light Flicker

Tech-Talks BREGENZ: Wolfgang Nemitz

Enabling Your Innovation™

From Concept to Production™

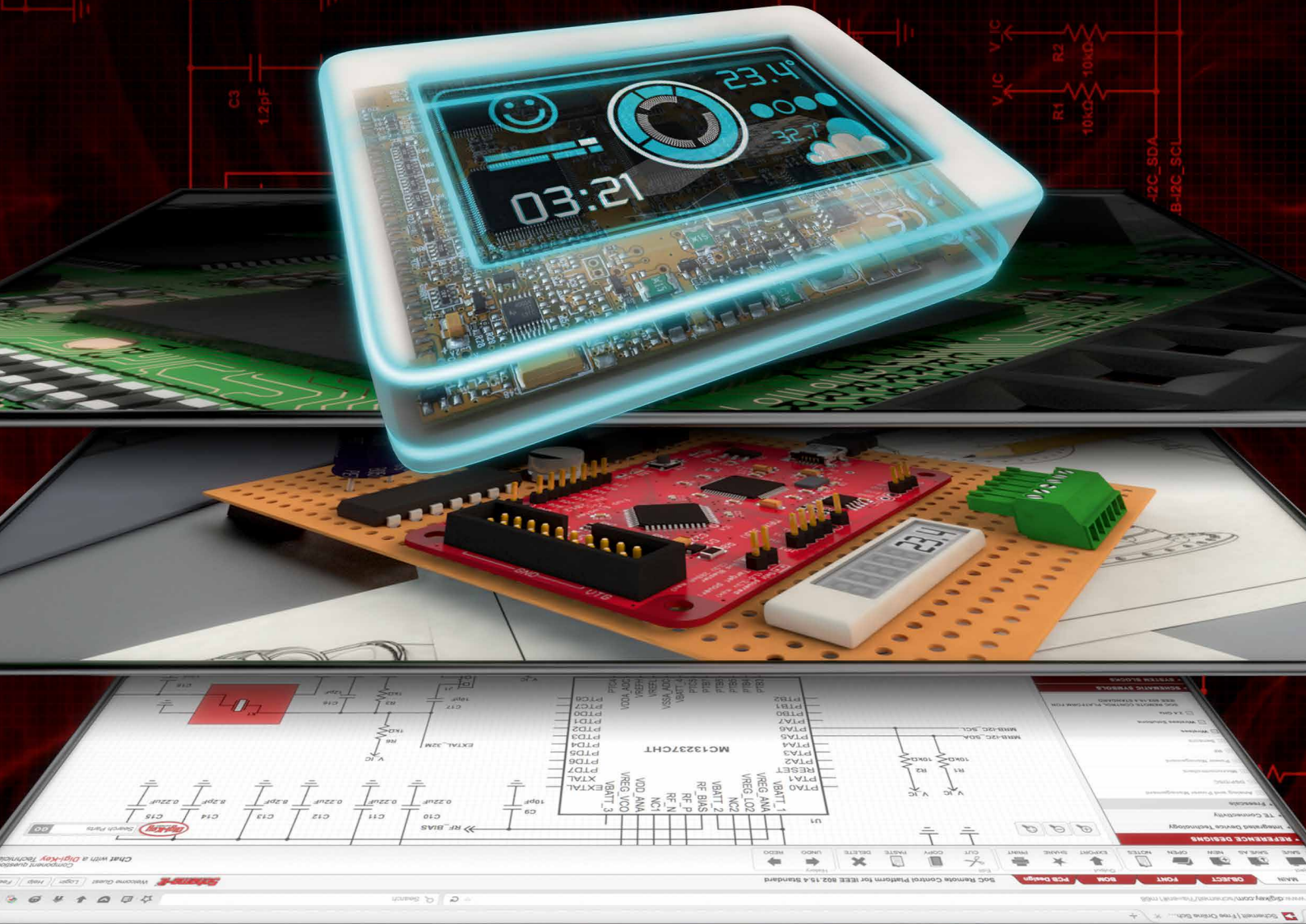

FREE SHIPPING
ON ORDERS OVER €65*

FIND CONTACT AND ORDERING
INFORMATION FOR YOUR REGION AT
DIGIKEY.COM/EUROPE



1,200,000+ PRODUCTS IN STOCK | 650+ INDUSTRY-LEADING SUPPLIERS | 100% AUTHORIZED DISTRIBUTOR

*A shipping charge of €18.00 (£12.00) will be billed on all orders of less than €65.00 (£50.00). All orders are shipped via UPS for delivery within 1-3 days (dependent on final destination). No handling fees. All prices are in euro and British pound sterling. If excessive weight or unique circumstances require deviation from this charge, customers will be contacted prior to shipping order. Digi-Key is an authorized distributor for all supplier partners. New product added daily. © 2016 Digi-Key Electronics, 701 Brooks Ave. South, Thief River Falls, MN 56701, USA



NEW CREE® XLAMP® LEDs CAN:

IMPROVE RELIABILITY::

REDUCE SYSTEM COST::

REDEFINE LED LIGHTING::

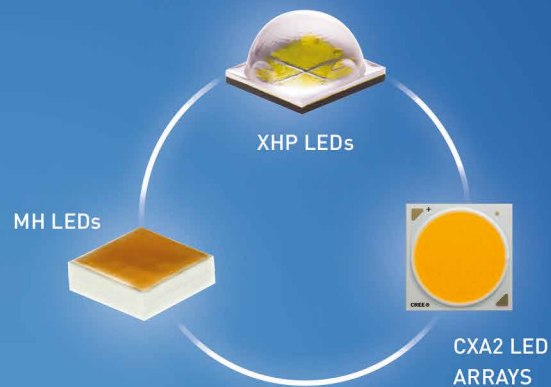

GAME CHANGING IS GREAT. BOTTOM LINE CHANGING IS BETTER.

You can't change your bottom line by using the same LEDs that everyone else is using. Cree's Extreme High Power (XHP) LEDs deliver double the lumen output at high operating temperatures, while our MH LEDs combine the system advantages of our best arrays with the manufacturing ease of a discrete. And our CXA2 LED arrays are packed with lumens to offer system cost savings up to 60%.

CREE 

See how higher power equals lower cost.
cree.com/xhp

The new way to a better LED array.
cree.com/mh

Even more lumens for savings up to 60%.
cree.com/cxa2

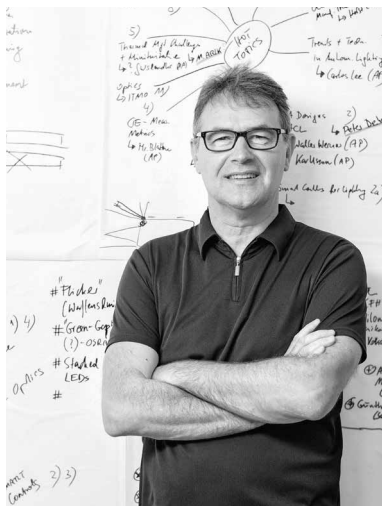

Re-Invented Lighting

Today, many business areas are influenced by our digital and internet-based world. Lighting seems to be triggered and affected the most because it reflects social changes, new ways of living and working, new views on architecture and design, the world of internetization, digitalization, sensing, control and wireless communication, the latest technologies, new power transmission opportunities, new business and has to reflect the needs of stakeholders, market players and organizations. But do we really need to re-invent light? The simple answer is YES. The more difficult question to answer is how to cope with all of these factors to transform a business into a success model. It is a challenging, fascinating and exciting task. We have to think completely OUTSIDE THE BOX and re-invent lighting - a great intention for 2016!

This year's first LpR issue is dedicated to light quality, human centric lighting and environmental issues in solid-state lighting. It will be distributed at the LED Tech Expo (Moscow, RU), the LED Taiwan, TILS (Taipei, TW), and at the Light + Building (Frankfurt, DE) in March 2016, where the LED professional team will be present at their own booth in hall 4 for the whole week.

Ed van den Kieboom covers the commentary with thoughts around the traditional Form Follows Function design cliché and how design and controls have to be seen under a "new light".

LED professional had the chance to interview DI Wolfgang Nemitz, the winner of the LED professional Scientific Award, during his visit to the LpS 2015. He talked about his findings the fact that the temperature of the LED surface is just a part of a set of thermal parameters that are required to analyze an LED, and which parameters are more critical for the design and for the prediction of the quality of an LED system.

Dr. Pranciškus Vitta from Vilnius University presents a human-centric lighting study to find the best lighting conditions for outdoor lighting, by a qualitative validation of the Kruithof hypothesis.

Researchers from the University of Erlangen-Nuremberg, led by Dr. Rubén D. Costa, propose White Hybrid LEDs as an alternative solution to eliminate the drawbacks of LEDs with inorganic phosphors that are costly, not optimized for all bandwidths and show problems with recycling.

Brad Koerner from Philips Lighting presents their view of embedded lighting for modern architectural projects. The integration of LEDs and OLEDs into objects is one of the really important trends for the next years. What are the challenges and opportunities when ceilings and objects light up rooms and environments?

Prof. Georges Zissis and his team at the Laplace University of Toulouse investigated the fundamentals for flicker in lighting. They explained how to measure flicker and their results according to valid standards. Finally, a study from Luminitt LLC presents the role of special optics in human centric lighting and for architectural applications.

With these articles in our first 2016 issue we want to start triggering the re-thinking process of lighting systems. A lot of new ideas and concepts can be found in this LED professional Review issue. Please let us know if you have any other ideas, concepts, technologies, products or projects that will help us to transfer light into another dimension.

Yours Sincerely,

Siegfried Luger
CEO, Luger Research e.U.
Publisher, LED professional
Event Director, LpS 2015

PS: Don't forget to submit your paper or workshop idea for the LpS 2016 on or before February 19th. Please submit your paper at: www.LpS2016.com/cfp

Q: LED lamps' flicker problem?

A: Lifud LF-GIRxxxYS series provides you the best flicker-free LED driver solution!

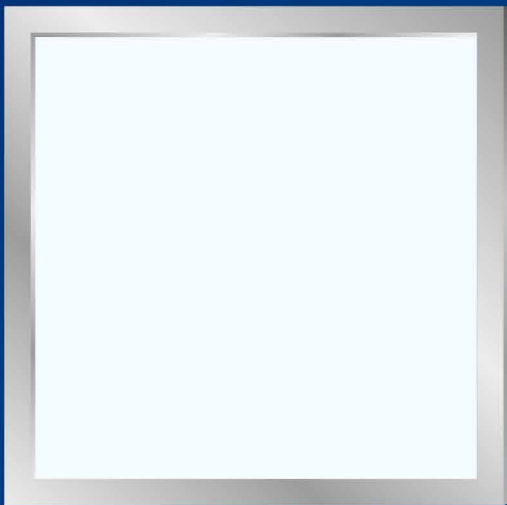

flicker-free

VS

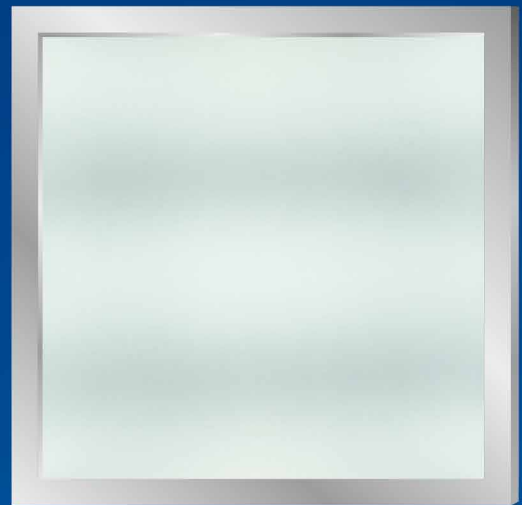

flicker



Features:

- * efficiency up to 91%.
- * THD as low as 6%.
- * flicker-free coefficient as low as 0.4%.
- * rated input voltage AC220-240V for European, South-east Asia and China markets.
- * output power 7W-60W for LED panel lights, down lights and ceiling lights.
- * 5 years warranty (24 hours working).



COMMENTARY

08 Design Beyond FFF
by Ed van den Kieboom, InnovationFab Events

TECH-TALKS BREGENZ

24 Wolfgang Nemitz, Scientist, Joanneum Research
compiled by Siegfried Luger, LED professional

RESEARCH

30 Human-Focused Outdoor Illumination:
Trade-Off Between Pleasing Color and Circadian Action
by Dr. Pranciškus Vitta, Vilnius University

36 White Hybrid Light-Emitting Diodes:
A Plausible Solution for Commercialization and Health Issues
by Rubén D. Costa et al., University of Erlangen-Nuremberg (FAU)

TRENDS

44 Embedded Lighting - Developing New Lighting Applications
for Modern Architectural Projects
by Brad Koerner, Philips Lighting

TECHNOLOGIES

50 Light Flicker from LED Lighting Systems - An Urgent Problem to Solve
by Prof. Georges Zissis, LAPLACE Université de Toulouse

APPLICATION

60 The Role of Special Optics in Human Centric Lighting and Architecture
by Anthony Ang, Suleyman Turgut & Mary Ann Giorgio, Luminitt LLC

REGULARS

04 EDITORIAL
08 COMMENTARY
10 PRODUCT NEWS
20 RESEARCH NEWS

66 ABOUT | IMPRINT

LEADING ARTICLE

44 Embedded Lighting - Developing New
Lighting Applications
by Brad Koerner, Philips Lighting



ADVERTISING INDEX

FUTURE LIGHTING SOLUTIONS	1	BARTHELME	18	FUTURE LIGHTING SOLUTIONS	35
DIGI-KEY	2	ELLSWORTH ADHESIVES	19	RECOM	37
CREE	3	PHOTOPTICS	19	REFOND	39
LEDFRIEND	5	HONGLITRONIC	20	GUANGZHOU INT. LIGHTING EXHIBITION	41
OSRAM	7	SEOUL SEMICONDUCTOR	21	INTERLUMI PANAMA 2016	43
OSRAM	9	LAMBDA RESEARCH	22	ELT	53
LEDLINK	11	INFINEON	22	CREE	58
EPISTAR	13	LEDIL	23	LED LIGHTING TAIWAN	63
FUHUA	14	LPS 2016	27	LEDTECHEXPO MOSCOW	64
VIAPAQ	15	EDISON	28	LED & OLED EXPO 2016	65
GLOBAL LIGHTING TECHNOLOGIES	16	INSTRUMENT SYSTEMS	29	LED PROFESSIONAL REVIEW	67
AMPHENOL LTW	17	LED LIGHT FOR YOU	33	WAGO	68



Light is brilliant Solid State Lighting Solutions

Light is OSRAM

OSRAM
Opto Semiconductors



Ed van den Kieboom

Mr. van den Kieboom has over 25 years of hands-on management experience in founding, launching, developing and managing public and private technology companies. He established his own company in 1992. As a consultant, he assisted Philips Electronics, Mitsubishi Electronics, and 7 other companies in the technology areas of optical storage, microelectronics, and information and communication technology to expand their businesses.

In 2005 he founded and managed the Plastic Electronics Foundation, a worldwide technology platform for printable organic electronics, with stakeholders from academia, research institutes and industry. In 2005 he also founded the Smart Lighting and Smart Sensing technology and business platforms that he manages today.

DESIGN BEYOND TRADITIONAL FORM FOLLOWS FUNCTION

Today design is omnipresent. But what is design? "Design" was first coined by the American architect, Louis Sullivan, to mean that the style of architecture should reflect its purpose; applicable for buildings and constructions and later on attributable to products and objects.

For several decades the sayings "form follows function" (FFF), followed by "less is more", became the most used and misused design clichés. World-renowned architects such as Le Corbusier and Mies van der Rohe took design to unprecedented levels providing a minimum of form and a maximum of functionality.

In the design of FFF products, these principles became common practice. Later, the FFF paradigm started to reverse. Designs and brands became the expression of specific lifestyles and the styling of products appeared to dominate its functions and user benefits.

Through the introduction of digital technology followed by several waves of electronic component miniaturization and the integration of these elements in single packages (SOC), electronic designers squeezed many functions into tiny form factors. Moreover, the integration of those functions in "single design architecture" allowed for an enormous surge in mass production. Industrial design and process automation walked hand-in-hand with mass manufacturing.

These revolutions in design and manufacturing have left the lighting industry untouched for more than a century. Electric lighting has contributed to higher levels of efficiency in working environments and added comfort and convenience to family dwellings.

Except for the development of new light sources like CFL and halogen, form and esthetics are still the dominating principles used for designing luminaires.

Lighting functions were restricted to being switched on and off, and later - dimmed. The bi-annual Light+Building tradeshow held in Frankfurt is an expression of the dominance of form over function.

Hit by LEDification and DIGitalization in less than a decade, the industry is challenged to stay on top of developments that are completely changing the way we work, live and play! The lighting industry must now re-invent itself! Major lighting companies are moving away from the component or lighting node business and becoming providers of more complex digital systems and solutions that control and manage light.

These tasks are largely determined by the design quality of the software like the user interface. If the UI is well designed, one should be able to use the device intuitively. Traditionally; software is not the domain of the lighting industry, so collaboration and alliances with non-traditional players from the semiconductor industry (MCU, Drivers, etc.) and from the ICT (API and PaaS) is a means towards survival.

On the other hand, over the last 150 years, the lighting industry has built an infrastructure that is available in constructions. Lighting provides the dominant infrastructure to the Internet of Things (IoT), which enables new IT solutions and services. As spatial design becomes the common battlefield of new entrants, the lighting industry dominates newcomers like telecoms and ISP's.

Smart Lighting Design enables UI friendly designs, where the room or space defines the conditions for the quality level of conditions (light, air, security, etc.) of the users. This brings back functionality and raises the question of how to avoid dullness and keep our work, play and living spaces attractive. ■

E.v.d.K.



Light is versatile
The new DURIS[®] S 5 portfolio

Light is OSRAM

OSRAM
Opto Semiconductors

2400 W Flip Chip CoB LED Using Patented 3-Pad Pillar Structure

Flip Chip Opto releases a first-in-class 2400 W high-power LED Flip Chip COB. This new Flip Chip COB is part of their flagship Apollo series based on the company's patented 3-Pad Pillar Metal Core Printed Circuit Board technology. This technology allows a breakthrough in high powered flip chip LEDs, reducing the junction temperatures to $0.003^{\circ}\text{C}/\text{W}$ on Apollo 2400.



FCO's Apollo 2400's very low thermal resistance is the basis for allowing its maximum power of 2433.6 watts

The Apollo series represents Flip Chip Opto's high powered Flip Chip COB lineup. The Apollo 2400 reaches a maximum power of 2433.6 watts, achieving a thermal resistance of $0.003^{\circ}\text{C}/\text{W}$ and a luminous flux of $> 230,000$ (lumens based on 80CRI and 5K CCT); it is ideal for extreme applications such as stadium lighting, nautical spotlighting, outdoor industrial needs, underground operations and many more. The Apollo 2400 is unique due to its thermal properties; allowing designers to maximize lumens-per-dollar by reducing the form factor of the light fixture, fixture optics, and the number of fixtures needed. ■

New Osram Duris S5 Color LEDs for Color Mixing Applications

For smart lighting solutions and all kinds of colored lighting applications, customers now can rely on the new Duris S 5 Color LEDs from Osram Opto Semiconductors. There are four color versions - Red, Amber, Green and Deep Blue - offering high efficacy and excellent temperature stability. The footprint of $3.0\text{ mm} \times 3.0\text{ mm}$ complies with industrial standards.



Osram's new Duris S5 Color LEDs are PC converted solutions and therefore have similar electrical and optical behaviors to the Duris S5 white pendants

Technical Data:

- Footprint (industry standard): $3.0 \times 3.0\text{ mm}$
- Forward voltage Vf at If=150 mA: typ. 6.2 V
- Colors:
 - red: 620 nm
 - amber: 610 nm
 - green: 545 nm
 - deep blue: 450 nm
- Brightness:
 - red: 28 lm
 - amber: 45 lm
 - green: 170 lm
 - deep blue: 420 mW
- Emission angle: 120°

All red, amber, green and deep blue Duris S 5 Color versions can be used in color mixing systems, as well as in combination with white LEDs. They are all based on the same chip technology using phosphor conversion to generate the saturated red, amber and green colors. Therefore they all feature the same electrical behavior and are compatible with the Duris S 5 White, which greatly simplifies driver design. In addition, the red and amber Duris S 5 versions are best in their class for lumen maintenance and temperature stability between 25° and 85° Celsius, reducing the complexity of color management in different conditions.

The use of red and amber in combination with white LEDs can compensate for missing colors in the white spectrum, thereby increasing the color rendering index (CRI) with rich Ra values. Further characteristics include an epoxy-based package and a footprint of $3.0\text{ mm} \times 3.0\text{ mm}$ that complies with industrial standards.

The green color versions offer an extremely high efficacy of 170 lm/W - a value which is three times higher than that of comparable standard green color LEDs. This reduces assembly costs as customers need fewer

Duris S 5 Color LEDs to achieve the same brightness level for their applications and can be more flexible in their PCB design. Brightness levels are high: 28 lm for red, 45 lm for amber, 170 lm for green and 420 mW for deep blue. ■

Everlight's 5630KK6D Series with up to 205 lm/W Efficiency

With the rise of energy-saving efforts worldwide and improvement of applications using LEDs as next-generation light sources, more emphasis is put on the performance of LED lighting components more than ever before. With Everlight's advanced 5630KK5D and 5630KK6D series (0.2 W), the luminous efficiency can be improved to over 205 lm/W (5000 K) to meet the demands for high luminous performance of commercial lighting lamps and fixtures.

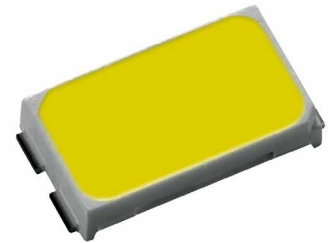

Everlight claims industry's highest optical efficiency of 205 lm/W for their new 5000 K mid-power 5630KK6D LEDs

Using plastic materials with high reflection/lifetime and improved optical structures, Everlight's 5630KK5D and 5630KK6D series are optimized to obtain the industry's highest optical efficiency of 205 lm/W (5000 K). Without modifying the circuit and PCB layout, the LED's brightness is efficiently increased. Therefore, the amount of necessary LEDs or power used is reduced to save more energy for the whole lighting application. Both LEDs allow less than 11 W power consumption when used to design a 2000lm finished product, which greatly reduces power consumption in a broad range of commercial lighting applications like office lighting.

Everlight's 5630KK5D series (0.2 W) with luminous efficiency 195 lm/W is mass produced already; the 5630KK6D series (0.2 W) with luminous efficiency up to 205 lm/W was scheduled for mass production in December 2015. Samples of both products are available for reference. ■

NEW PRODUCT



Medium Power Street Lens (In development)



TYPE II-M



TYPE II-S



TYPE III-M



TYPE III-S



DxWxH(mm) 50x50x5.3
Lumileds Luxeon 3030
Nichia 757D

Ultra-Thin Hybrid Lens



LL01ZZ-CPRxxL46

DxH(mm) 47x8.5
FWHM 24° 38°
CREE CXA13xx/ MHB
Citizen CLL010
Seoul ZC4/ZC6



LL01CR-CENxxL02

DxH(mm) 70x17.5
FWHM 12° 24° 38°
CREE CXA 15xx
Citizen CLL020/CLL030
Sharp Mini/ Mega Zenigata
Xicato XTM-9 / 19mmLES

Connector: LL01A00CZMB2-M2
(For: CREE CXA15xx)



LL01ZZ-CPQxxL46

DxH(mm) 74.4x13
FWHM 24° 38°
CREE MHD/CXA15xx
Citizen CLL020
Seoul ZC12/ZC18



LL01CR-CHQxxL02

DxH(mm) 35x10.5
FWHM 24° 38°
CREE CXA 13xx/ MKR2
Lumileds L2C1-1202

Connector: LL01A00CZNB2-M2
(For: CREE CXA13xx)



LL01CR-CEWxxL02

DxH(mm) 50x15
FWHM 12° 24° 38°
CREE CXA 13xx/15xx
Citizen CLL020/CLU700
Sharp Mini Zenigata
Xicato XTM-9mmLES

Connector: LL01A00CZNB2-M2
(For: CREE CXA13xx)



LL01CR-CEOxxL02

DxH(mm) 90x19.5
FWHM 12° 24° 38°
CREE CXA 15xx/18xx/25xx
Citizen CLL030
Sharp Mega Zenigata
Xicato XTM-9 / 19mmLES

Lumileds Introduces LUXEON XR-M to Accelerate Outdoor Fixture Design

Designed specifically as a turnkey solution for outdoor LED fixtures, today Lumileds introduces the LUXEON XR-M line of Matrix Platform solutions. These versatile building blocks integrate 3, 4 or 5 LUXEON M LEDs on a metal core PCB, providing a platform that enables fixture manufacturers to accelerate their design of streetlights, high bay and low bay luminaires. For instance, the 4 LED square version, in combination with industry standard optics and driver, yields a complete IP66 solution.

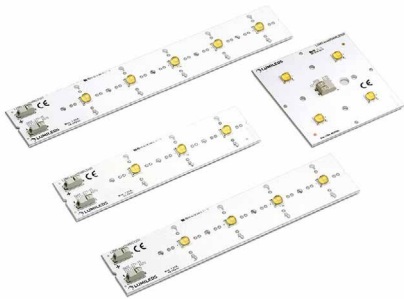

Using the industry-leading LUXEON M, LUXEON XR-M can be combined with standard lenses, lens plates and easily-mounted drivers to provide the industry's simplest LED solution for streetlights, etc.

"LUXEON XR-M incorporates LUXEON M, one of our most efficient and top selling, high power LEDs. The boards can be connected in parallel or series for driver design flexibility, and the wide variety of lens options means designers have multiple turnkey options to release a full range of luminaires much faster to market," said Andrew Cohen, Product Manager of the Matrix Platform at Lumileds.

The LUXEON XR-M achieves excellent efficacy at the board level of 140 lm/W at 4000 K, 70 CRI, $T_c=85^\circ\text{C}$ and 700 mA drive current. Using constant pitch between the LEDs and PCBs, combining multiple LUXEON XR-M modules achieves the most uniform, distributed light patterns.

Each LUXEON XR-M module provides 3,300 to 5,500 lumens and is available in color temperatures of 4000 K, 5000 K and 5700 K with a minimum CRI of 70. This new product is part of the Lumileds Matrix Platform of infinitely configurable LED boards, linear flex and modules featuring LUXEON LEDs. The Matrix Platform comes

in both off-the-shelf and built-to-spec options, offering a virtually limitless range of solutions for any application. ■

LEDiL Introduces Angelette Family for Uniform Indoor Architectural Lighting

LEDiL introduces six new Angelette family members with the following symmetrical light distributions: narrow spot, medium flood and wide flood. All the Angelette's share a smooth, glare-free and uniform light pattern, and are optimized for high quality office spaces, hospitality and museum lighting purposes.



Light distribution examples for an Angelette reflector for different LED types

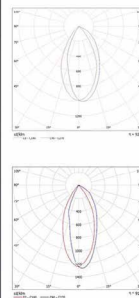

Light distribution example for one of LEDiL's Angelette reflectors for different LED types

Features:

- Part of LEDiL's System Reflector philosophy; future-proof and versatile solution sharing the same interface with LEDiL's Angela and Aangelina reflector families
- Works with TE, Molex an Ideal solderless 50 mm Zhaga book 3 compliant connectors
- Industry standard 110 mm diameter
- Angelette-Plain versions come without additional optical attachment interface for cleaner appearance

Typical Applications:

- Office lighting
- Hospitality lighting
- Museum lighting

Angelette reflectors have standard 110 mm diameter and are based on LEDiL's existing Angela-interface offering unsurpassed compatibility and ease of installation with a range of third party connectors. ■

Cost-Effective Dimmable LED Driver with Wide Triac Compatibility from Diodes

The AL1696 LED driver introduced by Diodes Incorporated is designed to fit a wide range of triac-dimmable lighting applications, especially retrofit lamps. An integrated MOSFET, which also eliminates the need for an auxiliary winding, reduces BOM cost and component count while the option of three MOSFET voltage/current ratings provides design flexibility for meeting manufacturing requirements for residential lighting.



Diodes' AL1696 LED driver offers MOSFET options for 3 A at 300 V, 2 A at 500 V and 2 A at 600 V

The AL1696 is based on buck or buck-boost topology and implements constant current conversion with a high power factor by operating in boundary conduction mode. This also reduces switching noise, easing EMI/EMC testing and qualification. The design only requires a single winding inductor and achieves a tight current sense tolerance of $\pm 3\%$. The device features a low operating current of 120 μA , with a 150 μA startup current, and is compatible with a wide of leading-edge and trailing-edge dimmers, providing compliance with the NEMA SSL6 dimming curve.

MOSFET options for 3 A at 300 V, 2 A at 500 V and 2 A at 600 V enable the AL1696 to be matched to end-market line-input voltage requirements and allow it to be used in LED lamps up to 12 W. The AL1696 is offered in a small outline SO-7 package that is configured with an extra pin space between the high-voltage MOSFET drain and its low-voltage pins to increase electrical isolation. The device also features internal protection for output short circuit, over-temperature, under-voltage lockout, leading-edge blanking and cycle-by-cycle over-current protection. ■

New 96 W Line Voltage Dimming LED Driver from TRP

Thomas Research Products has introduced a new high performance 96W LED driver with line voltage dimming. The driver features universal input and works with both leading edge and trailing edge dimmers. Thomas Research Products manufactures SSL power solutions.



TRP's latest LED drivers from the LED96W-LT series are flicker-free dimmable constant current drivers

The LED96W-LT series accepts universal 120-277V AC input. The new constant current design provides flicker-free output. It is compatible with both high-quality standard incandescent (leading edge) and electronic low voltage (ELV, or trailing edge) phase cut dimmers.

TRP's new driver is Type HL Recognized by UL for use in hazardous locations. The new IP66 rated Black Magic™ thermal advantage plastic housing is intended for damp location use. It comes with the company's standard 5 year warranty.

All LED Drivers from TRP offer high quality, long life, high efficiency and are cost-competitive. Information is available on the company's website now. Availability of LED96W-LT series driver begins in the first quarter of 2016 ■

Adjustable Current Regulators from Diodes for LED Strips

The BCR420U and BCR421U constant-current regulators (CCR) introduced by Diodes Incorporated provide a simple means of driving low-power linear LED strips. Target applications are those that benefit from the improved efficiency, flexibility and longer life offered by LEDs as an emerging lighting source. These include LED strips for mood lighting, emergency and advertising signage, and decorative lighting for retail refrigeration and vending machines.

The BCR420U and BCR421U allow an optimized LED current to be set giving a uniform brightness and extend the LED longevity. Supporting adjustable currents from 10 mA to 350 mA allows for platform designs based on a single device to be used across multiple

EPISTAR

1996 - **20th**
ANNIVERSARY



light+building 2016

Date

13. - 18.03.2016

Location

Messe Frankfurt Fairground

Booth

6.2 C71



EPISTAR Corporation
5 Li-hsin 5th Road, Hsinchu Science Park,
Hsinchu 300, Taiwan
T: +886 3-567-8000 F: +886 3-579-0801
sales@epistar.com.tw www.epistar.com



Website Facebook



UE Electronic
Since 1989

320W outdoor LED driver
(UEL320-A1Z)
24-48V DC 6.66-8.88A

36W indoor LED driver
(UE36LCPI-SPA)
12-24V DC 0.1-3.0A
UL, TUV, CE, CCC, CB, RCM

PSB BSMI SABS WEEE ISO 14001:2004
ISO 9001:2008 CEC OHSAS 18001:2007

CB CCC CQC UL US C-UL US FC
CE JET TSC ENEC GS

Fuhua Electronic Co., Ltd
Fuhua Electronic Industrial Park, Xianglong Rd.,
Huangzhou New Town, Shilong, Dongguan,
Guangdong, China
Tel: (86) 769-8602 2222 Fax: (86) 769-8602 3333
www.fuhua-cn.com E-mail: fuhua@fuhua-cn.com

LED string applications, considerably easing a manufacturer's overall qualification process. These LED drivers also enhance system reliability as the monolithic integration of a transistor, diodes and resistors both simplifies system design and reduces component count.



Diodes' new constant-current regulators can be adjusted to currents from 10 mA to 350 mA and offer an input rating of 40 V

A negative temperature coefficient, which reduces the output current as the temperature increases, allows current sharing between two or more of these CCR devices. This enables them to be connected in parallel to create a higher current output

without risk of thermal runaway. The 40 V maximum input rating provides sufficient headroom for transient supply voltages and allows for LED short failures on long strings. With its low-side driver configuration, the BCR421U has the added feature of an enable function that can adjust the light output level using a PWM input signal. Both devices are supplied in SOT26 packages, providing pin-compatibility with other sources. ■

Goeee Announces the World's First Enterprise IoT Gateway for Lighting and Sensing

Goeee, the smart lighting ecosystem provider that connects OEMs to the Internet of Things, has developed, out of Silicon Valley, a multi-protocol enterprise IoT gateway that connects lighting and sensing devices to its cloud platform.

Developed to include features such as a cloud-integrated OS, the gateway supports multiple communication protocols including Bluetooth, Zigbee and WiFi (for commissioning) chips for wireless communication, along with both an Ethernet and Serial port. This enables the gateway to provide maximum interoperability options with other on-premise or cloud-based services.

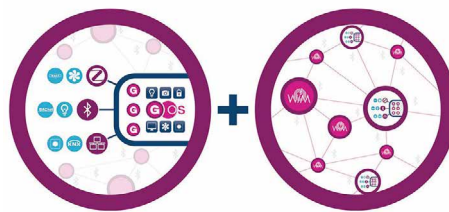

Schematic mesh structure of Goeee's multi-protocol enterprise IoT gateway that connects lighting and sensing devices to its cloud platform

Recognising that no existing IoT hub or 'gateway' has the capability to deliver the connectivity necessary for its lighting ecosystem to reach full potential, Goeee designed and engineered the gateway to offer increased reliability, connectivity and interoperability. As Chief Technology Officer Simon Coombes explains:

"In the early stages of our eco-system's development we planned to work with existing gateway devices, but were unable to

find anything that offered the adequate support for our platform to run efficiently and reliably."

Also featured is an ARM based processor, the ability for offline capability through a local and secure RESTful API and MQTT over WebSockets, and a localised secure app-container to allow third-party service integrations. Furthermore, the gateway will run Goeee's Bluetooth Mesh, which has been purpose-engineered for its lighting and sensing end-points and is capable of handling the bandwidth needed for the volume of sensing data created through Goeee's recently announced Sensing ASIC.

To complement the new technology, Goeee created and built a separate device to extend the range and end-point count that the gateway can support. Named the "Puck", it is a Power-over-Ethernet to Bluetooth extender device that runs the Mesh protocol and works with the gateway to extend the device's range and increase the number of end-point 'hubs' that are managed by the technology.

"Ensuring we can handle the wide range of environments is critical, so having offline capabilities with a local, security conscious API, and a distributed multi-gateway environment means we offer our customers better performance levels found within costly on-premise hardware," said Simon.

"Many hub and gateway manufacturers claim their devices support thousands of end-points, in some cases tens of thousands. That might be possible if you need a limited amount of control and are just turning groups of lights on and off. At Goeee, we are dealing with individual end-point control and a vast sensory network generating large quantities of environmental and energy data - put simply, our gateway is designed for this kind of enterprise scale," Simon concluded. ■

Exclusive Deal Leads to World's Smallest Sensor for LED Lighting & IoT

Goeee, the original "Full-Stack", smart lighting ecosystem provider, has created the world's smallest sensor for LED lighting and the Internet of Things (IoT) that now includes the latest Artificial Eye technology following an exclusive agreement with DELTA

Microelectronics, a European leader in fabless ASIC design, sensor systems, lighting and optics.

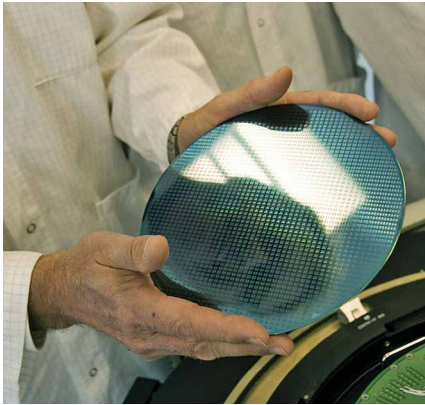

Gocee's advanced ASIC will be able to detect different parameters - all packaged in a 5x5 mm chip

The agreement, announced at the Hong Kong Lighting Fair, in effect creates a new "standard" in sensing, data and control for the LED lighting industry, and sees Gocee becoming the sole provider of this new, innovative Opto-ASIC technology to luminaire manufacturers. It also follows Gocee's announcement of the exclusive partnership with EVERYTHING's IoT cloud platform, enabling Gocee to operate tens of millions of intelligent light endpoints in a global network.

Boasting multiple environmental, human and LED performance sensing capabilities, the advanced ASIC will be able to detect motion, direction, ambient light, LED colour temperature (CCT) variance, LED lux variance and ASIC operating temperature - all packaged in a 5x5 mm chip.

A step closer to connecting LED lighting manufacturers to the IoT with its unique "Full-Stack" operating platform, Gocee has partnered with DELTA to focus on co-engineering and further developing more advanced sensing capabilities: "At present we are only scratching the surface in terms of what this chip can do," said Gocee CTO Simon Coombes. "We are working on some really incredible functionality that will give Gocee and its customers a significant competitive advantage in sensing for the IoT."

Gert Jørgensen, DELTA's VP of Sales & Marketing is delighted to be partnering with Gocee on such an exciting venture: "We have invested significant time and

money in R&D into our Artificial Eye technology, and have found a perfect application in the lighting and IoT world," he added.

Founded in March, 2014 by successful entrepreneur Andrew Johnson, Gocee has been in development for two years. DELTA has a track record of more than 70 years, and can boast a 35-year history in module manufacturing with companies like Nordic Semiconductor and IBM. "DELTA has a successful history of developing technology-driven products, and specialises in the core competencies that we need to make our ASIC work, so we are really excited about this project," Coombes continued. "We are the only global company with exclusive access to this technology in the lighting sector."

Gocee is also co-developing a new Bluetooth meshing protocol with a major Wireless IC provider. This technology, along with the other on-premise components of Gocee's ecosystem, will allow light fixtures to communicate two-way, enabling control, sensing, human engagement and asset tracking - all fully integrated into its enterprise cloud platform. ■

MEGAMAN Unveiled New INGENIUM Product Line Products

MEGAMAN®, an innovative developer and manufacturer of LED lighting, debuted an upgraded version of INGENIUM® BLU and a brand new member of the INGENIUM® Smart Lighting family - INGENIUM® ZB - at the Hong Kong Lighting Fair 2015 (Autumn Edition).



Megaman joins the ZigBee LightLink community with its INGENIUM® ZB line

VIAPAQ

LIGHTING

'Innovative luminaires deserve breakthrough LED modules'

Introducing ActivePAQ

1200mm and 1500mm linear LED modules with integrated mains powered driver.



Uniquely enabling cost effective luminaire designs.

20mm or 33mm wide, 4000lm and 6000lm, state-of-the-art LED's, All electronics integrated.

Visit us at Light&Building
Hall 4.0, Booth C25

www.viapaqlighting.com

ULTIMATE PERFORMANCE IN AN LED LIGHTGUIDE.

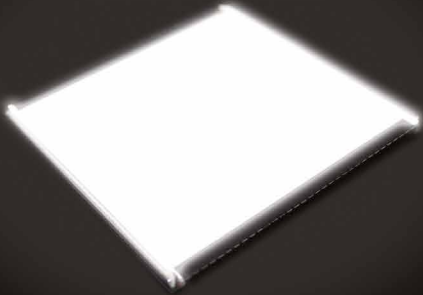

low cost
thin
durable
long life

excellent uniformity
large range of sizes



www.glthome.com

See Us at Strategies In Light
in Booth 615

INGENIUM® BLU:

Making its debut at the Lighting Fair, MEGAMAN®'s upgraded version of INGENIUM® BLU is packed with new features and enhancements. Giving users simultaneous control of up to 8 times more lamps or devices (64) than with its first generation products, the upgraded INGENIUM® BLU system also boasts improved dimming performance with a range of 100%-5%.

The upgraded INGENIUM® BLU Generation 2 system uses a mesh network topology - a key network architecture that extends the coverage area several times wider than before and allows for the control of substantially more lamps - all while using less of your smart device's battery power.

By using smart devices and the new and improved INGENIUM® BLU app, users can control INGENIUM® BLU lamps directly, and without any need for additional wiring. Alternatively, if your users don't have an INGENIUM® BLU lamp, they can install the brand new INGENIUM® BLU dimming module giving them smart control of all MEGAMAN® LED products. Providing easy integration and outstanding value, the INGENIUM® BLU range has also been extended to include the SIENA LED Downlight, as well as the much-loved LED Classic and PAR16 GU10 providing a variety of options for all applications.

INGENIUM® ZB:

Also launched at this year's fair INGENIUM® ZB - a brand new range based on a common standard that acts as a bridge between general lighting and full smart home solutions.

Using the ZigBee® protocol, INGENIUM® ZB allows users to gain wireless control over all of their INGENIUM® ZB lighting products. Compatible with many other ZigBee® smart home solutions, INGENIUM® ZB works with its very own gateway, or popular third-party ZigBee® compatible super-gateways to add quality lighting to modern smart home solutions.

Another big advantage of INGENIUM® ZB is that it is scalable, providing a wider wireless coverage utilizing mesh network technology to allow control of over 200 lamps simultaneously. Similar to

INGENIUM® BLU, INGENIUM® ZB lamps are controlled through users' smart devices via corresponding apps. In addition, you can add the INGENIUM® ZB dimming module into your network to control all standard MEGAMAN® LED products. Ideal for the professional and high-end consumer market, INGENIUM® ZB is available in LED Classic lamps and INGENIUM® ZB luminaires. ■

Aurora Introduced Their First Smart Product - AOne™ Control Module

First presented 2013 Hong Kong International Lighting Fair and updated at Light+Building in Frankfurt, Aurora's first smart product, the AOne Control Solution, is now available after being launched at the Hong Kong Lighting Fair 2015.

The AOne control app communicates with the LED luminaires via the AOne hub. Partnering with Zigbee, the hub transmits the signal from the app into a message enabling the lamps to react to the instructions given.



Aurora Lighting's AOne is a ZigBee LightLink based controls system

ZigBee is the only open, global wireless standard to provide the foundation for the Internet of Things by enabling simple and smart objects to work together, improving comfort and efficiency in everyday life.

The ZigBee Alliance is an open, non-profit association of approximately 450 members driving development of innovative, reliable and easy-to-use ZigBee standards. The Alliance promotes worldwide adoption of ZigBee as the leading wirelessly networked, sensing and control standard for use in consumer, commercial and industrial areas. ■

STMicroelectronics' New VIPer0P IC to Slay Vampire Power

The reign of dreaded “vampire power” could be about to end thanks to the latest power-supply chip from STMicroelectronics, a global semiconductor leader. The new IC meets the international specification for zero standby power, and is the first in the world to provide a smart way of managing the wake-up function in appliances such as white goods, in lighting and in industrial equipment.

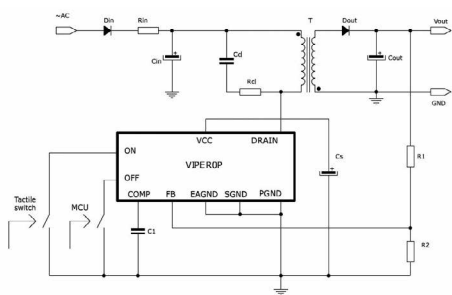

The VIPer0P offers a unique zero-power mode reducing standby losses to below 5 mW

Key Features:

- Smart stand-by architecture using the Zero Power Mode (ZPM)
- ZPM management by MCU easily realizable
- 800 V avalanche-rugged power MOSFET allowing ultra wide VAC input range to be covered
- Embedded HV startup and sense-FET
- Current mode PWM controller
- Drain current limit protection (OCP)
- Self-supply option allows to remove the auxiliary winding or bias components
- Jittered switching frequency reduces the EMI filter cost
 - 60 kHz $\pm 7\%$ (type L)
 - 120 kHz $\pm 7\%$ (type H)
- Embedded E/A with 1.2 V reference and separate ground for easy negative voltage setting
- Protections with automatic restart: overload/short circuit (OLP), max. duty cycle counter, VCC clamp
- Pulse-skip protection to prevent flux-runaway
- Embedded thermal shutdown
- Built in soft start for improved system reliability

Key Data:

- Wide supply voltage range: 4.5 V to 30 V
- Minimized system input power consumption:
 - Less than 4 mW @ 230 VAC in ZPM
 - Less than 10 mW @ 230 VAC in no-load condition
 - Less than 400 mW @ 230 VAC with 250 mW load

The long-running battle to minimize power sucked in by equipment in standby mode (vampire power) has driven worldwide adoption of proposals such as the IEA1 initiatives to reduce standby power used by appliances to less than 1 W in 2010 and 0.5 W in 2013. Today, the most advanced power-supply technologies are capable of driving down standby power consumption below 5 mW, which is rounded to zero according to the IEC standard for household and office appliances.

Although regulations are driving down standby power per appliance, the number of appliances in use globally is increasing. ST's new VIPer0P IC helps reduce wasted

Simple Topology and Limitless Possibilities

Amphenol LTW's "Intelligent Pre-Cabling System" (IPCS) is the sensible choice and solution for your LED lighting infrastructure requirements; for both indoor and outdoor applications. Available utilizing a wide selection of Amphenol LTW's interconnect products, IPCS provides architects and designers with peace of mind allowing them the freedom to create and innovate lighting wonders.

- Easy Maintenance
- Virtually Zero Waste
- Fool-proof Plug & Play
- Low Maintenance Cost
- Low Cost of Ownership
- No Prior Training Required
- Effective Schedule Control Tool
- Simplistic and Minimalistic Design
- Reduced Labor Force Required for Installation
- Significant Installation Time and Cost Reduction
- Available for AC, DC, or Hybrid Solutions
- Compliant to Various Fire & Safety Regulations

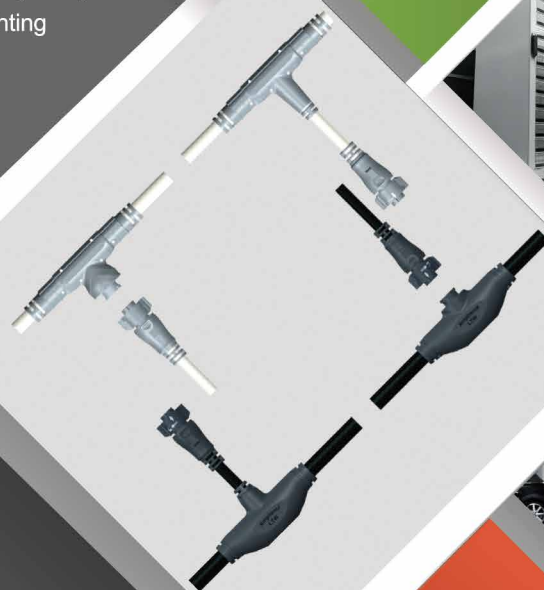

13th ~ 18th March 2016
light+building
 Hall 9.0 Booth E85

sales@ltw-tech.com
 www.amphenolltw.com

Amphenol LTW

AQUALUC® C:URVE MINI BRAVING ALL ELEMENTS

Flexible and absolutely homogeneous
LED luminaire

6mm slim with a bending radius of only 5cm

Resistant against water, UV radiation,
abrasion and chemicals (IP 67/68)

Optimised heat dissipation
thanks to special coating

Barthelme
LED Solutions

www.barthelme.de

power and CO₂ emissions by enabling effective zero-power standby in appliances such as clothes dryers, washing machines, dishwashers, coffee makers, and microwaves. The chip can also be used in lighting controls, industrial appliances, and air conditioners. By introducing a unique, patented smart-management capability not offered by any other converter in the market, VIPer0P allows the appliance to be woken from standby via a touchscreen or remote control thereby enhancing convenience for users.

“Designers at the world’s leading appliance brands rely on our VIPer® avalanche-rugged integrated power ICs to meet the toughest eco-design specifications,” said Matteo Lo Presti, Group Vice President, Industrial & Power Conversion Division, STMicroelectronics. “VIPer0P now adds advanced zero-power technology to the superior ease of design, energy efficiency, and ruggedness that characterize the VIPer family.”

Further Technical Information:

Thanks to its unique smart architecture, VIPer0P is able to provide standby power for the system host microcontroller while in idle mode. This allows the system to be woken via the main-appliance user interface, such as the touchscreen or a remote controller. There is no need for a dedicated high-voltage mechanical switch to take the appliance out of standby. VIPer0P consumes less than 5 mW in idle mode (at 230Vac supply). This best-in-class performance is rounded to zero power according to Clause 4.5 of the IEC 62301 standard for household and office appliances.

If a switch is used to control standby, idle power can be further reduced to 4 mW. Switching can be done at Safety Extra-Low Voltage (SELV), hence eliminating bulky high-voltage components.

VIPer0P is an off-line power-converter IC that can be configured as a flyback, buck, or buck-boost switched-mode power supply (SMPS). As the latest member of ST’s high-voltage VIPerPlus series, it integrates an avalanche-rugged Power MOSFET with class-leading

breakdown voltage of 800 V thereby giving designers greater safety margin to ensure superior reliability. VIPer0P also has comprehensive protection features including short-circuit protection, V_{cc} clamping, thermal shutdown, and soft-start. The oscillator controlling the switching frequency is jittered to minimize electromagnetic interference.

Additional features include integrated high-voltage startup circuitry, error amplifier with 1.2 V reference and separate ground for direct feedback connection, and a sense-FET for energy-efficient current sensing. These simplify design and minimize external components thereby saving bill-of-materials costs and board space. In addition, VIPer0P’s self-supply design simplifies transformer selection by eliminating any need for an auxiliary winding. ■

MechaTronix Expands LED High Bay Cooler Program

Many tier A LED brands like Cree, Citizen and Tridonic have recently boosted their offerings in COB LED packages with new models performing lumen outputs from 10,000 all the way up to 20,000 lumens. As ECO partner of most A LED brands MechaTronix took up the glove to develop a range of high power passive LED coolers.



The MechaTronix ModuLED Giga is a highly efficient passive high bay LED cooler

Five months ago MechaTronix announced their first off-the-shelf high bay LED cooler for designs up to 10,000 lumens with the ModuLED Mega LED heat sink design.

Now a second platform of standard LED coolers launches for high bay and industrial LED designs up to 15,000 lumens.

The ModuLED Giga is a passive high bay LED cooler in a diameter of 152 mm and height 150 mm with an optimal thermal performance of 0.46°C/W. In these compact dimensions 100 W of dissipated power, equivalent to 150 W electrical power, would lead to a temperature rise of 40°C over the ambient temperature.

The modular design of the ModuLED Giga allows direct mounting of a wide variety of LED modules directly on the LED cooler without the need of extra drilling and tapping. Most suitable LED engines for high bay designs over 10,000 lumen like the Cree CXA3070 or CXA3590, Citizen Citiled CLU56 third generation, Edison Edipower III HM high power or Tridonic Talexx Stark FLE can be fixed immediately to the ModuLED Giga. Besides modularity when using LED modules as well as driver and optics flexibility the ModuLED Giga is one-of-a-kind. Creating a flush-look with the Mean Well HBG-160 high bay led driver on the top, or adding an external driver box for your other driver of choice, it is all standard.

Optics wise MechaTronix has developed standard optic adaptors which allow immediate implementation of a variety of lenses and reflectors. On the same optic adaptor a wide score of lenses as well as reflectors in aluminium and polycarbonate can be mounted. Design wise MechaTronix has followed the most common industrial standards on available optics for high bays.

Since thermal validation in this extreme high power range is primordial, MechaTronix performs extended lab tests with a combination of each high power COB package and the LED cooler and publishes these results per brand in a thermal compatibility matrix. Small variations like the size of the board, pressure of the fixation from the board to the LED cooler, internal junction to case thermal resistance and the use of perfect thermal interface material have such a big thermal impact in these extreme power designs, that MechaTronix advises asking for a consultation in case of new designs. ■

Amendment and Rectification for LpR52

LED professional apologizes for incorrectly citing the authors of Infineon's article "Software Design in LED Lighting Applications".

The introduction should read as follows:

Creating light with LEDs is a fairly complicated task. A lot of small problems need to be solved before AC or DC voltage is converted to the desired visible light. This conversion is done by electronic control gears (ECG), often called LED ballasts or LED drivers (although this naming is sometimes considered to be a bit incomplete). Attila Tomasovics, application engineer, and Ivan Dobes, Product Marketing Manager XMC Industrial Microcontrollers at Infineon Technologies, discuss a new emerging trend whereby, instead of dedicated ASICs or general-purpose microcontrollers, hybrid digital controllers control these LED drivers. ■

From Lighting to Electronics...

e ELLSWORTH
ADHESIVES

Specialty Chemicals for Your Complete Lighting Assembly
Adhesives | Sealants | Potting Material | Thermal Management

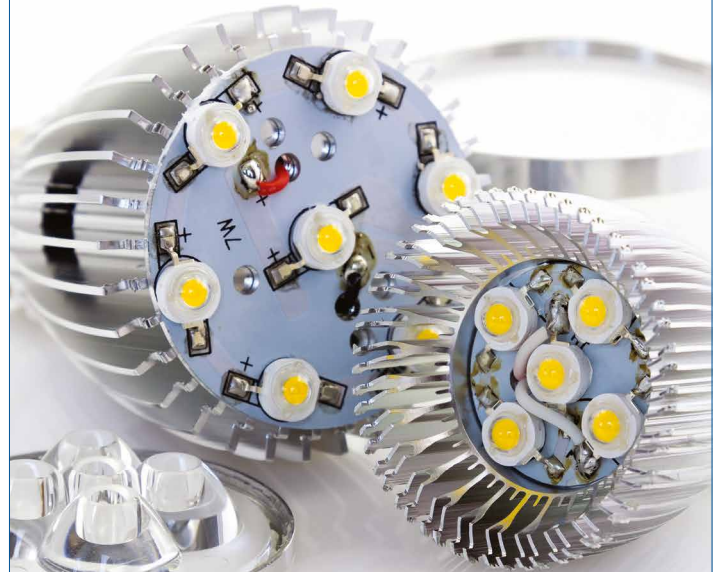

Ask the
Glue Doctor®
1.800.888.0698
ellsworth.com

Products from
DOW CORNING
Henkel
FISNAR & more!

PHOTOPTICS 2016

4th International Conference on
Photonics, Optics and Laser Technology

ROME, ITALY | 27 - 29 FEBRUARY, 2016

CALL FOR PARTICIPATION



MORE INFORMATION AT: WWW.PHOTOPTICS.ORG

Research Publications in the Journal of Solid State Lighting

On December 24th and 29th, 2015, three new articles have been published in the SpringerOpen Journal of Solid State Lighting. The three articles are titled “Optical Role of Die Attach Adhesive for White LED Emitters: Light Output Enhancement without Chip-Level Reflectors”, “The Importance of Intrinsically Photosensitive Retinal Ganglion Cells and Implications for Lighting Design”, and “Towards Perceptual Accuracy in 3D Visualizations of Illuminated Indoor Environments”.

Optical Role of Die Attach Adhesive for White LED Emitters: Light Output Enhancement without Chip-Level Reflectors

A thin optical reflector is often introduced to the backside of the standard mesa type light emitting diode (LED) chip with the aim to enhance its light output. However, most of the reported light output enhancements because of backside reflector (BR)

introduction might not be relevant. This is because the reported measurement is often from a naked LED chip instead of a packaged LED emitter, and those based on the packaged emitters employing conventional silver based die attach adhesive (DAA). The actual role of BR, which is expected to be greatly influenced by the packaging materials and processes, is investigated for the monotonic blue color

and white LED emitters using Monte-Carlo simulations. Contrary to prior reports, it is demonstrated for the first time that the role of BR can be diminished when the optically transparent DAA is used and other key packaging materials and processes are optimized, i.e., the light output for a packaged emitter with a BR-free chip can be as high as that of the packaged emitter using the same chip but with an added BR.

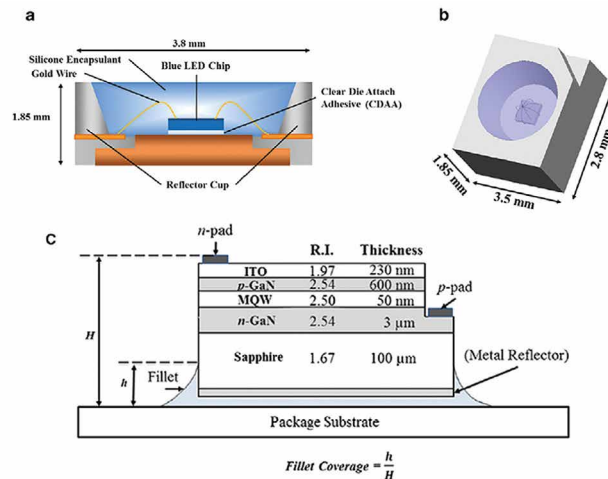

Leadframe based LED emitter:
 (a) Schematic cross section of a packaged LED emitter by using optically clear die attach adhesive (CDAA), (b) optical model used in Monte-Carlo simulations and (c) microscopic enlargement of the blue LED chip attached on the leadframe substrate by using CDAA. Layers are not plotted in their relative thickness in order to present illustration. The size of the chip is 24×24 mil (0.61×0.61 mm) and the thickness is about 100 μm



HONGLITRONIC
 鸿利光电
 Stock Code: 300219

We are Leading the White Light LEDs



CSP



SMD



COB



AC



UV

light+building

Welcome to Light + Building 2016
 Booth: Hall 10.1, D30
 March 13-18th, 2016



Official website

Guangzhou Hongli Opto-Electronic Co., Ltd

Tel: +86-20-8673 3333 ext 3033

Fax: +86-20-8673 3883

E-mail: sales@honglitrionic.com

www.honglitrionic.com

About Authors & Authors' contributions:

Gunwoo Kim (GK), Yu-Chou Shih (YCS), Jiun-Pyng You (JPY), and Frank G. Shi (FGS) GK proposed the topic, established simulation models and carried out simulations.

YCS carried out experimental study and analyzed the results.

JPY analyzed the simulation and experimental results and helped in their interpretation.

FGS collaborated with the corresponding author in the construction of manuscript. All authors read and approved the final manuscript.

The Importance of Intrinsically Photosensitive Retinal Ganglion Cells and Implications for Lighting Design

The article is a summary of research results and gives a good overview on a topic with many still unanswered questions which is currently often discussed very controversially. The authors reviewed the role of melanopsin-containing intrinsically photosensitive retinal ganglion cells (ipRGCs) in light-dependent

functions, including circadian rhythm that is important for health and visual perception.

They finally discussed the implications for lighting design.

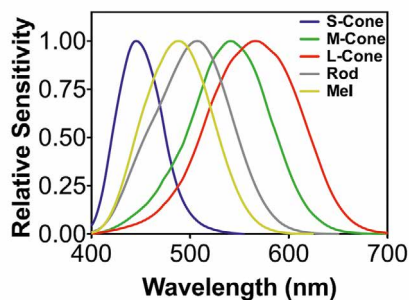

Human photoreceptor spectral sensitivity functions

About Authors & Authors' contributions:

Dingcai Cao (DC), & Pablo A. Barrionuevo (PAB) DC conducted literature search, graphic preparation and data analysis and wrote the manuscript.

PAB assisted in literature search, graphic preparation, data analysis and manuscript preparation.

Both authors approved the final manuscript.

Towards Perceptual Accuracy in 3D Visualizations of Illuminated Indoor Environments

Through a series of experiments, the authors have measured the extent to which 3D visualizations of a variety of lighting conditions in an indoor environment can accurately convey primary perceptual attributes. The goal was to build and rigorously test perceptually accurate visual simulation tooling, which can be valuable in the design, development, and control of complex digital solid-state lighting systems. The experiments included assessments of lighting-related perceptual attributes in a real-world environment and a variety of virtual presentations. Iteratively improving choices in modeling, light simulation, tonemapping, and display led to a robust and honest visualization pipeline that provides a perceptual match of the real world for most perceptual attributes and that is nearly equivalent in perceptual performance to photography.



light+building

13 – 18. 3. 2016

You will find us here:
Hall 6.2, Stand A04

Good bye packaging!
Hello WICOP!

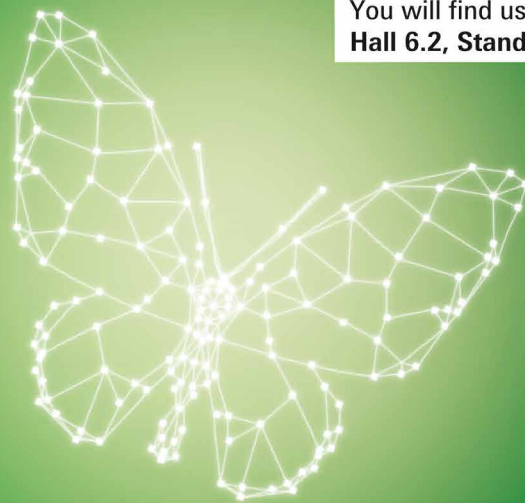

World's First Package-free LED for General Lighting, *Wicop2!*
Excellent cost savings with high lumen density and design flexibility



SEoul SEMICONDUCTOR
www.seoulsemicon.com

One persistently difficult attribute is scene brightness, as observers consistently overestimate the brightness of dimmed scenes in virtual presentations. In this paper the authors explain the experimental 3D visualization pipeline variables that were addressed, the perceptual attributes that were measured, and the statistical methods that were applied to evaluate the success.

About Authors & Authors' contributions:

Michael J. Murdoch (MM), Mariska G. M. Stokkermans (MS), and Marc Lambooi (ML) MM led the project that included this research; [co-] designed all experimental variations, and drafted much of this paper. MS co-designed and executed several experiments, performed the statistical analyses, and drafted the results section. ML co-designed and executed one experiment and assisted with analyses and paper draft. All authors edited and approved the final manuscript.



Low-intensity image:
Is this an underexposed image of a normally-lit room or a properly exposed image of a dim room?

Additional information about the articles and authors is available at the Journal of Solid State Lighting SpringerOpen website. The article can also be directly downloaded from the LED professional website. ■

WEBINARS



Lambda
Color Effects Webinar

Modeling Color Effects in Modern Optical Analysis Software - by Lambda Research

Lambda Research Corporation will present a comprehensive webinar on smart designs to model color effects in LED lighting systems using modern optical analysis software.

Register to view the webinar and to download the presentation!

www.led-professional.com/lambda-color-effects



Infineon
LED Lighting Webinar

CoolMOS™ CE and LED Driver ICs - The Ideal Combination from LED Tubes to LED Drivers

Learn more about CoolMOS™ CE, the proven benefits of superjunction technology, and the powerful combination of CoolMOS™ CE and the suitable LED Driver ICs.

Watch our webinar!

www.led-professional.com//Infineon-Webinar-0915



LEDiL

From Light to Lighting

LEDiL, with design expertise in Finland and production facilities in Europe and China, is the leading optics supplier to the world's premier lighting manufacturers. Providing a wide range of optical solutions that combine innovative designs with excellent performance makes LEDiL the first choice for demanding applications. Close connections with the top LED manufacturers allow LEDiL to release products alongside the newest LEDs; and their customers to enjoy rapid development and deployment of new fixtures with the latest technology. A selection of over 3000 standard and 1500 custom products combined with a "can do, will do" attitude ensure you find the product you need for your application. With a global network of distributors and free of charge technical support to all customers LEDiL guarantees you the most competitive solutions available today. For more information, please visit www.ledil.com



World leading optics

Shaping light the way you have always dreamed of

Visit us at **Light+Building**
Frankfurt am Main
13.3. - 18.3.2016

Our location:
Hall 4.0, Booth E20



www.ledil.com

Tech-Talks BREGENZ - Wolfgang Nemitz, Scientist Joanneum Research



Wolfgang Nemitz

Wolfgang Nemitz studied Electrical Engineering and Audio Engineering at the Graz University of Technology and the University of Music and Performing Arts in Graz, Austria. His thesis on the acoustic behavior of measurement tubes concluded his studies at the Institute of Electronic Music and Acoustics in 2010. Later he joined the Institute for Surface Technologies and Photonics at the Joanneum Research Forschungsgesellschaft in Weiz, Austria where he now works on optical simulations in the fields of solid-state lighting and white light engineering.

Wolfgang Nemitz, scientist at the Joanneum Research Forschungsgesellschaft, won the LED professional Scientific Paper Award at the LpS 2015 in Bregenz with his paper entitled “Iterative Optical and Thermal Simulation Method for Proper Simulation of PC LEDs” (published in the LpS 2016 Proceedings / p. 122 and LpR 52 / p. 48). Siegfried Luger and Arno Grabher-Meyer took this opportunity to discuss his research, the practical value of the findings and general solid-state lighting issues with him.

LED professional: Congratulations Mr. Nemitz, on the LED professional Scientific Award handed to you here at the LpS 2015. In your excellent paper you talk about simulating phosphors to generate white light. Can you tell us how you got started?

Wolfgang Nemitz: My work mainly concerned the incorporation of temperature dependent optical parameters into an existing simulation model. The important thing for the optical simulation of color converters that are made from phosphor particles embedded in silicone is to have valid scatter models for the blue light as well as the yellow light. Based on this, we can simulate in which part of the converter the blue light is absorbed and where the yellow light is reemitted.

LED professional: How is the basic architecture of the simulation model constructed?

Wolfgang Nemitz: We can consider the color conversion layer to be a block or volume. This volume has the characteristic of a material like silicone with embedded phosphor particles. There are scattering models for the phosphor particles based on parameters like a minimum, maximum and average size and a standard deviation for each size. In addition, the concentration, the refraction index and the quantum efficiency of the phosphor are defined.

LED professional: Are these parameters adequately known for the phosphors that are used?

Wolfgang Nemitz: You have to determine the optical parameters - mostly experimentally - but afterwards you can adapt the model. For instance, in experiments with fabricated color conversion layers we determined the refractive indexes with ellipsometry. Furthermore, we determined the temperature dependent luminescence intensity of the phosphor in the laboratory. We were also able to measure the thermal conductivity



Wolfgang Nemitz proudly receives the LpS 2015 Scientific Award

of very thin phosphor layers and apply the results to the entire simulation model. In the model we assume certain statistic scattering within the conversion layer.

LED professional: The wavelength in which the phosphor particle reacts should be relatively precise. The primary emission of the blue LED scatters relatively wide. Does that mean that the entire system of LED and phosphor always has to be known for the system simulation?

Wolfgang Nemitz: That is absolutely right. We use an LED chip for blue light as the basis for the simulations of the white light. We checked the measurements and simulations for a specific LED and examined that type of LED very carefully. If we take a different LED as a basis or maybe a different color converter, then the examinations have to be done again.

LED professional: How precisely do the measurement results correspond to the simulation results on the basis of your model?

Wolfgang Nemitz: The better you know the basic data (the optical parameters, the characteristics of the LED chips, the shape of the color converter, the shape of the optics and the thermal properties), the more precise the results will be.

LED professional: Can you stay within two MacAdams ellipses if you take all requirements, like a 45°-80° angle into account?

Wolfgang Nemitz: All the silicones used have temperature dependent characteristics, whereby the color conversion layers can be arranged neatly. An optimal arrangement can be found for the phosphor material as well as additional silicone layers in order to keep the color coordinates within two MacAdams ellipses.

LED professional: What key findings have your studies shown over the years?

Wolfgang Nemitz: We actually just recently made a crucial discovery. The color conversion layer doesn't have

To verify the simulation, practical measurements were made: The Steady-state temperature distribution at a forward current of 350 mA was measured by emission-corrected high-resolution IR-thermography with a microscope lens

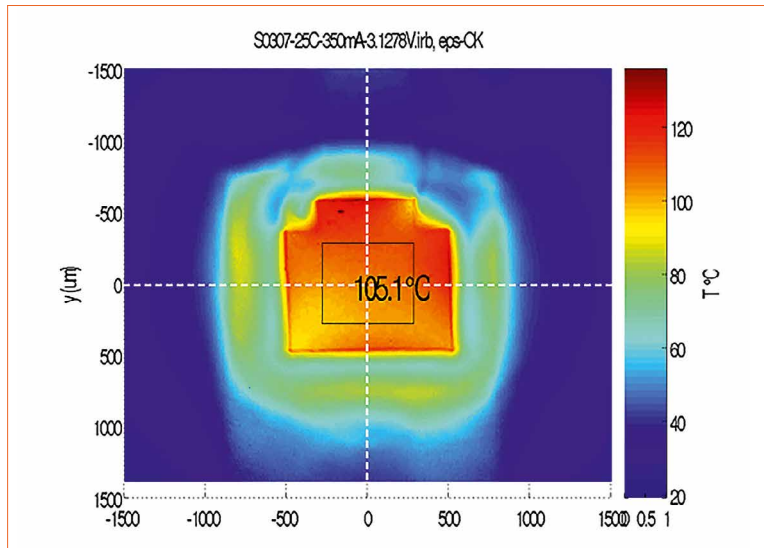

the same temperature throughout. The temperature in the lower areas (close to the chip surface) is lower, whereas the temperature of the upper surface is much higher. That was well known up until now. What we discovered is that there is a connection between the different temperatures and the various aspects or parameters of white light emission from an LED. When, for example, the maximum temperature is examined in order to determine the risk for materials degradation, one has to consider the temperature at the upper surface of the color conversion layer. This surface temperature can be determined with simulations or infrared thermography. In order to make prognoses on the color coordinates, one has to know the temperatures of those regions of the color conversion layer that are near the LED chip. We showed that these are the areas of the color converter for which the phosphor particles mainly contribute to the emission. When running an LED on 1 A we measured a surface temperature of about 300°C and a temperature of only 140°C close to the LED chip. The conversion layer was about 250 µm thick in this set-up.

LED professional: Why is the outside layer so much hotter than the inner zone?

Wolfgang Nemitz: The heat generated by the blue LED can be dissipated easily to the PCB

(and a cooling plate beneath). Unfortunately, the Stoke's shift losses which occur upon color conversion produces heat in the color conversion layer. When the quantum efficiency of phosphor is less than 1, additional heat is produced and this heat can't be dissipated because of the poor thermal conductivity of silicone. Of course there are approaches trying to improve heat dissipation from the color conversion layer. In this regard phosphor ceramics or crystal phosphors play an important role because they have fundamentally better thermal characteristics.

LED professional: At the LpS we heard that in the future LEDs will be built into materials, ceilings and other things. Could simulations for embedded lighting also be carried out?

Wolfgang Nemitz: We have already worked together with partners to integrate light into ceilings using appropriate materials in the model. In any case, it is crucial to understand the thermal and optical characteristics of the materials.

LED professional: When evaluating the papers for the LED professional Scientific Award, the advisory board paid special attention to the practical relevance of the papers. Why do you think your paper received such high marks for this point?

Wolfgang Nemitz: The practical relevance is that we can now differentiate between the various temperatures that have to be taken into account for the observation of various effects of Phosphor Coated (PC) LEDs like surface temperature in case you want to make estimates of the risk of material degradation. There is now a simulation model available that runs optical and thermal simulations iteratively. For example, if we start with the optical simulation at room temperature this will be based on certain scatter characteristics of the color converter and this results in a distribution of blue light absorption. In turn, this is the basis for the thermal simulation because blue light absorption determines where, taking into account the quantum efficiency and the Stoke's shift losses, the heat is produced inside the color converter. And the temperature distribution from the thermal simulation is used for a new optical simulation because the blue light absorption distribution changes with different temperatures and therefore, in turn, has to be calculated again on the base of the temperature distribution. The result can be repeatedly entered in a new thermal simulation.

LED professional: Is this research result unprecedented?

Wolfgang Nemitz: As a rule, in the LED community one mainly talks about thermographic measurements of maximum temperatures or outside temperatures. Lower temperatures near the LED chip are not taken into account or are not known because they can't be determined by infrared thermography. In addition to being able to determine the risk of material degradation, now the color coordinates can be predicted. These are unprecedented results.

LED professional: Can you tell us about the research team at Joanneum Research?

LpS 2016

LED SYMPOSIUM
professional +EXPO

Call for Papers

ENDS FEB 19th

www.lps2016.com/cfp

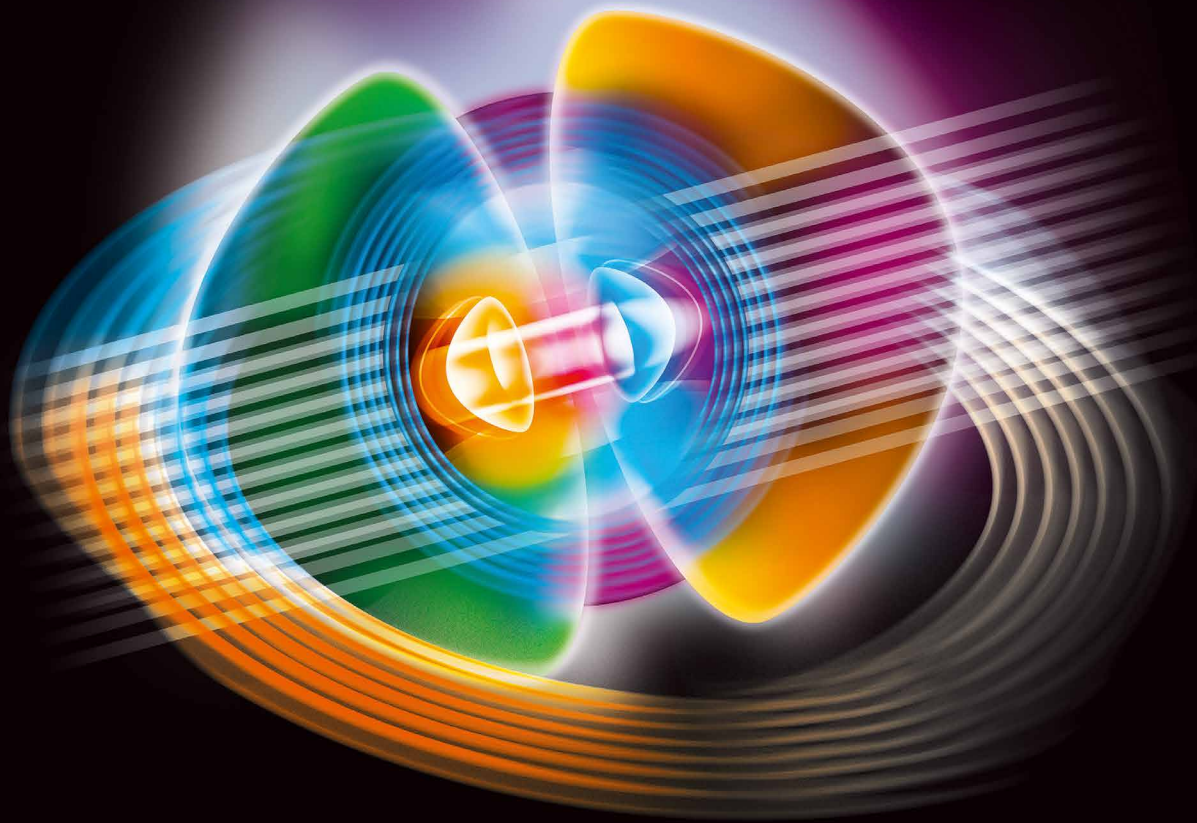

6TH LED professional Symposium +Expo

Smart Technologies for Lighting Innovations

Sept 20th - 22nd 2016 | Bregenz | Austria

www.lps2016.com

Organized by Luger Research e.U.

Wolfgang Nemitz: Our team is made up of ten to twelve researchers. In the area of thermal simulations we work together with Professor Johann Nocolics' group from the Institute for Sensor and Actuator Systems at the Vienna University of Technology.

LED professional: What do your future research plans look like?

Wolfgang Nemitz: There is still a lot to examine. For high temperatures we still need additional methods for characterization. In this high temperature regime the measurements are a bit more difficult because we have to eliminate several effects.

LED professional: This is your fourth year at the LpS in Bregenz. What is your opinion of the fifth anniversary conference and expo?

Wolfgang Nemitz: The LpS event is continually improving. The program is very appealing and compact. I find it very positive that new aspects of lighting are taken up every year. This year I found the design exhibition very interesting. Here you can see how the focus has changed over the years. New aspects are coming to the forefront and are presented very nicely. All in all, a great development for the LpS event in Bregenz.

LED professional: What do you say about the exhibition?

Wolfgang Nemitz: What I noticed is that the exhibition has grown continuously and there are more people here every year. Since our research is very application related and we work with many industry partners, the LpS is a very good platform for us to make contacts and also to intensify the contacts we have. The award that we won this year also has a very good publicity effect. Our clients that are here see that we work very well on a scientific basis. And that makes us very happy.

LED professional: Thank you very much for the interview. It was very interesting. Again, congratulations!

Wolfgang Nemitz: Thank you. ■

Copyright©2016 Edison Opto Corp. All rights reserved



High Efficiency LED Module

LED Module

- Light weight & easy assembly
- Uniform light distribution
- Design-in quick expansion
- 3-Step MacAdam ellipse
- Smart lighting solution available

Multi-type Module
 • Circle Type • Linear Type
 • COB Type • Light Engine

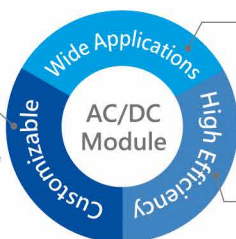

AC : 110 lm/W CRI>80
 DC : 160 lm/W CRI>80

High Efficiency LED

↑ to 200 lm/W

2835 HE

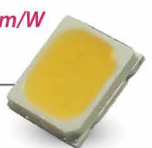

light+building

3/13-3/18 2016
 visit us at Hall 4.2 Booth E91

www.edison-opto.com



We bring quality to light.



See Instrument
Systems at Light
& Building 2016,
Hall 4.1/K 89

Meet every LED & SSL test standard!

Solutions from Instrument Systems satisfy all applicable international & European standards for highly accurate LED/SSL measurements like CIE S025, EN 13032-4 and the ErP directive.



LGS 1000
Goniophotometer
with new features

Opt for our expertise and quality!

- Leading test equipment for standard & high-power LEDs as well as OLEDs
- Proven measuring solutions for high-speed production, high-performance R & D and quality control applications
- Accurate and reliable results as per CIE methods and recommendations
- Engineered and made in Germany

 **Instrument
Systems**

KONICA MINOLTA Group

Human-Focused Outdoor Illumination: Trade-Off Between Pleasing Color and Circadian Action

A smart RGBA solid-state light engine with tunable correlated color temperature (CCT) and high-fidelity color rendition was applied for the validation of the Kruithof hypothesis in several outdoor environments. Subjects were asked to find the most “pleasing” illumination conditions by performing a CCT adjustment. Maintaining constant illuminance, the mean selected CCT was found to increase from about 3000 ± 200 K at 5 lx to about 3500 ± 250 K at 50 lx almost independently of the content of the viewed scene. Dr. Pranciškus Vitta, Head of Lighting and Electronics System Lab at the Vilnius University shows that this increase is statistically significant and provides qualitative validation of the Kruithof hypothesis in outdoor environments, but with the intervals of CCT for “pleasing” illumination, it is substantially broader and shifted to higher values.

The correlated color temperature (CCT) of a light source is defined as the temperature of an ideal black-body radiator that radiates light of the same hue as the light source under test. The light within the range of 2,500 to 10,000 K is usually treated as “white” with warm yellowish and cool bluish hues at the low and high ends of the CCT range, respectively. Until the era of solid-state lighting, the available colour temperatures were limited to a finite number of choices due to the technological limitations of incandescent, fluorescent and discharge lamp technology. In 1941 A. A. Kruithof, the researcher of Philips Labs, raised the hypothesis that humans prefer light of different CCT under certain conditions of illuminance [1]. Despite the incomplete experimental data,

the key point of the Kruithof hypothesis is the existence of the regions of illuminance levels and colour temperatures that are perceived by an observer as “pleasing” (Figure 1). According to this work the “pleasing” lighting conditions

are achieved within the narrow area between the red and blue curves in figure 1, while the upper and lower areas are perceived as unpleasantly yellowish and bluish, respectively.

Figure 1: Kruithof hypothesis - the area between two curves is claimed to delineate the conditions for “pleasing” illumination

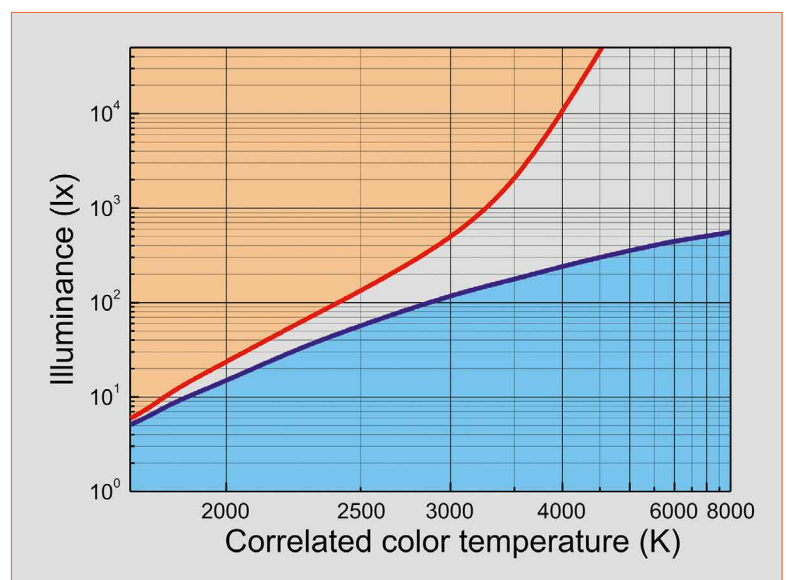

Plenty of studies were performed in order to confirm or deny the Kruithof predictions. Most of the studies were focused on indoor office or household illumination conditions with illuminances ranging from 100 to 1000 lx. Some researchers performed studies with a large number of subjects and claimed to confirm the hypothesis qualitatively by finding the trend of increased CCT with increasing illuminance. Moreover, the subjective ranking of fluorescent lamps has shown that the most “pleasing” CCT for office environments is around 4000 K, which agrees with the Kruithof. On the other hand, the other independent research groups have revealed the preference to higher illuminance irrespectively of CCT [2]. Such findings imply that the range of “pleasing” CCTs might exist for a constant illuminance, but for a constant CCT, the higher the illuminance the more “pleasing” conditions. Also, no effect of CCT on task performing and cognitive activity was found at the office illuminances of 300-600 lx, but the influence of the CCT on mood was observed.

For outdoor environments, practically no scientific evidence exists to support the Kruithof predictions because of the very narrow intervals of “pleasing” CCTs proposed for low illuminances. For the illuminance recommended by the European standard on road lighting (2-50 lx), the Kruithof implies the most “pleasing” CCTs to be below 2500 K. Occasionally, the high-pressure sodium (HPS) lamp technology, which was introduced several decades after the Kruithof work, became the most popular outdoor light source. HPS lamps deserved this success due to significantly high luminous efficacy (80-140 lm/W), relatively small size, long lifetime and color rendering properties better than those of low pressure sodium ancestors. Later, when new technologies started breaking into the outdoor lighting market, HPS lamps were considered as reference light sources to compare with and evaluate the

new ones. Despite the success story of HPS lamps, scientists still try to find the most appropriate CCT for illuminance conditions typical of outdoor environments. Again, subjective feelings such as comfort and safety in parking lot environment were shown to increase with increasing illuminance for both HPS and metal halide (MH) types of lamps (2000 K and 4250 K, respectively) with no effect of the CCT [3]. On the other hand, some other studies showed that subjects prefer LEDs or MH lamps of warm white and cool white colors (ca. 3000-4000 K) in respect to HPS (1900 K); however the effects of color rendering and CCT on subject decision making have been not distinguished.

In addition to the visual satisfaction effects described above, short-wavelength light has non-visual (photobiological) effects on humans and other living beings, especially at nighttime. Therefore the switching from blue-deficient light sources to blue-enriched ones is actively debated. [4] In particular, with the discovery of intrinsically photosensitive retinal ganglion cells, which contain blue-light absorbing melanopsin photopigment, the application of blue-enriched light (MH lamps and common LEDs) in night-time environments is recognized to be harmful due to the suppression of pineal melatonin secretion and the shift of melatonin time-phase even at low illuminances [5]. Melatonin is recognized as one of the main oncostatic hormones in human body also responsible for the circadian rhythms. Therefore addressing the melatonin suppression ability of light while selecting “pleasing” CCT in outdoor environments is also important.

Below we demonstrate the variation of the subjectively selected “pleasing” CCT with illuminance for different outdoor environments. Also is shown the readiness of subjects to sacrifice pleasantness when the selection of CCT is subjected to dimming in order to maintain constant circadian irradiance.

Experiment

Keeping in mind both subjective visual comfort and photobiological action, the Lighting Research Group of Vilnius University performed an experiment with a tunable multicolor LED based light engine. Custom design outdoor luminaires consisting of four color high power LEDs (red, amber, green, and royal blue) and wirelessly controlled 4 channel power supplies were employed for the smooth adjustment of the CCT of light [5]. The image of the experimental scene is presented in figure 2 where the luminaires are mounted on 4.2 m high ladders (the experimental equipment can be also seen). The control algorithm inside the remote computer was able to instantaneously maintain the high color fidelity regime ($R_a > 91$) in the entire CCT adjustment range by running the color-mixing optimization routine for the four primaries. Subjects were allowed to synchronously control the two luminaires via a smart phone graphical interface with unscaled slider by selecting the desired CCT within 1850-10000 K linear range using the forth and back adjustment in 10 K increments. The examples of light spectra for different CCTs are depicted in figure 2a. Also, the software allowed for operating the illumination conditions in two experiment modes. In the first mode, the constant illuminance (photopic 5 x and 50 lx, which correspond to EN 13201 standard road classes S4 and CE0, respectively) was maintained by the luminaires while adjusting the CCT and this regime was employed to validate the genuine Kruithof hypothesis. In the second mode, the software limited the circadian action of the illuminance by dimming the luminaires when blue rich (higher CCT) lighting was selected. The 5 lx and 50 lx illuminations by HPS lamp (1900 K) were used as circadian action irradiance reference points measured in arbitrary units and equivalent to “5 arb. u.” and “50 arb. u.”, respectively. The circadian action was calculated as an integral of the spectral power distribution of light weighted by the circadian

Figure 2:
Experimental environment within Bursų courtyard of Vilnius University



Figure 3:
Spectral power distributions of the tunable light source for different CCTs in the constant illuminance (solid lines) and constant circadian irradiance (dashed lines) regimes (left). Dependence of circadian dimming factor on CCT (right)

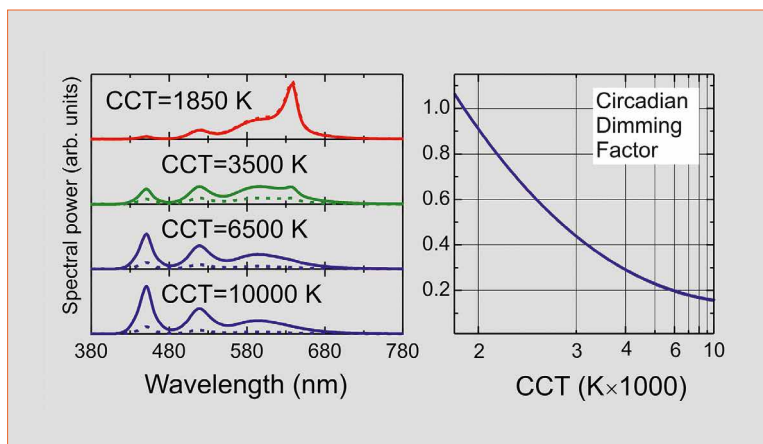

efficiency function [6]. The dashed lines in figure 3a show the spectra of the light engines in the constant irradiance mode, while the dependence of the dimming factor on CCT is depicted in figure 3b. After adaptation to certain illuminance level, each of the respondents was asked to make four selections of the most “pleasing” CCT under two constant illuminance and two constant circadian irradiance conditions.

The experiments were performed within three environments in Vilnius city. The main experiment was arranged in the Bursų courtyard of the historical campus of Vilnius University. The gray pavement,

yellowish and reddish walls and single green tree were the dominating objects of the field of subject’s view. The supplementary experiments were carried out in the park area (Botanical Garden of Vilnius University) and in the area of modern city (near Lithuanian National Gallery of Art) with the dominating green and brown, and grayish color hues, respectively. The supplementary experiments were carried out to check whether different surroundings could have an influence for the selection of the most “pleasing” color temperature of illumination. 40 respondents took part in the main experiment while 22 and 27 subjects participated in the supplementary experiments,

respectively. The subjects were mostly Vilnius University students and staff of age ranging from 19 to 57 (in average 24) with 43% of females and 57% of males.

Results and Discussion

The summarized results of the research are depicted in figure 4. The colored solid bars show the obtained mean values of the “most pleasing” CCT for each of the four conditions and three environments with the confidence intervals depicted as error bars. Wide confidence intervals evidence the large scatter of the individual judgment results. Despite large scattering, a characteristic shift from about 3000 K to about 3500 K can be seen with increasing illuminance from 5 lx to 50 lx under constant illumination conditions. These values correspond to “warm white” range of white light and are significantly higher than those predicted by Kruthof (gray horizontal lines in Figure 4). Interestingly that in earlier experiments with fixed number of light sources [3], this range of CCT was missed and no difference in preference was found between HPS and “cool white” MH lamps. Qualitatively similar trend (increase from 2500 K to 3200 K) can be noticed for constant circadian irradiance conditions when changing from 5 arb. u. to 50 arb. u. On the other hand, the CCT selection difference when changing from constant illuminance to constant circadian irradiance regimes depends on the illumination level. At low circadian irradiance (5 arb. u.) subjects preferred to have more light at noticeably lower CCT of about 2500 K in comparison with that in the constant illuminance regime (about 3000 K). In this case, the illuminance dimming factor had a moderate value of 0.6. At higher circadian irradiance (50 arb. u.), the mean selection was about 3200 K, which does not significantly differ from that in the constant illuminance regime (3500 K). However, in this case they complied with a much lower illuminance (dimming factor of 0.4).

Visit us at
light+building
Hall 6.2, Booth C04

13.-18.3.2016
Frankfurt a.M.
Germany

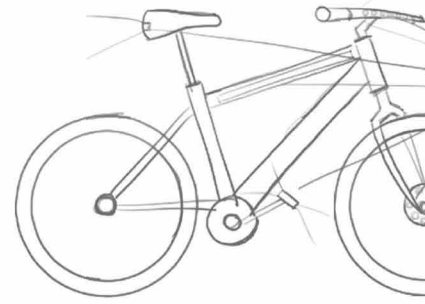
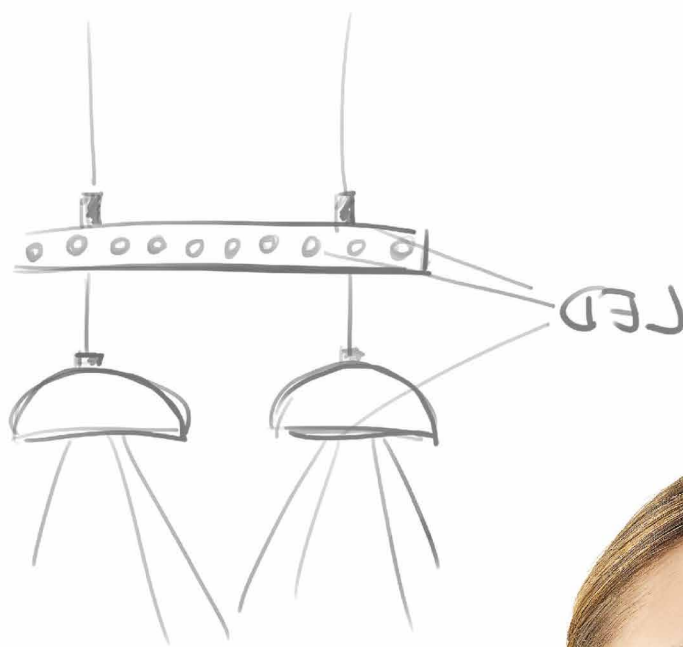
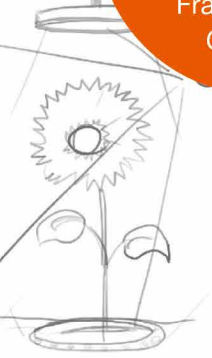

**YOU HAVE THE IDEA,
WE HAVE THE SOLUTION.**

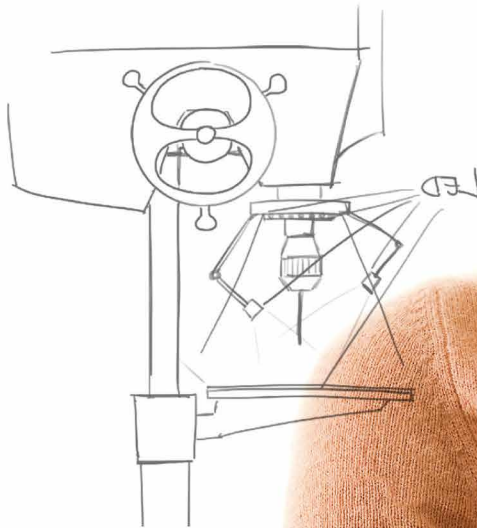

Rely on our extensive experience when implementing your LED lighting idea. We provide customized solutions and support you professionally in the realization of your project. Put us to the challenge!

For more information, please see www.ledlightforyou.com

LLFY Selector App



The network for LED lighting technology

LED  **Light for you**
powered by OSRAM

Figure 4: Solid bars are mean values of the most “pleasing” CCT in three environments and four experimental conditions. The intervals of pleasing conditions proposed by Kruithof and current study are between the gray and green lines, respectively

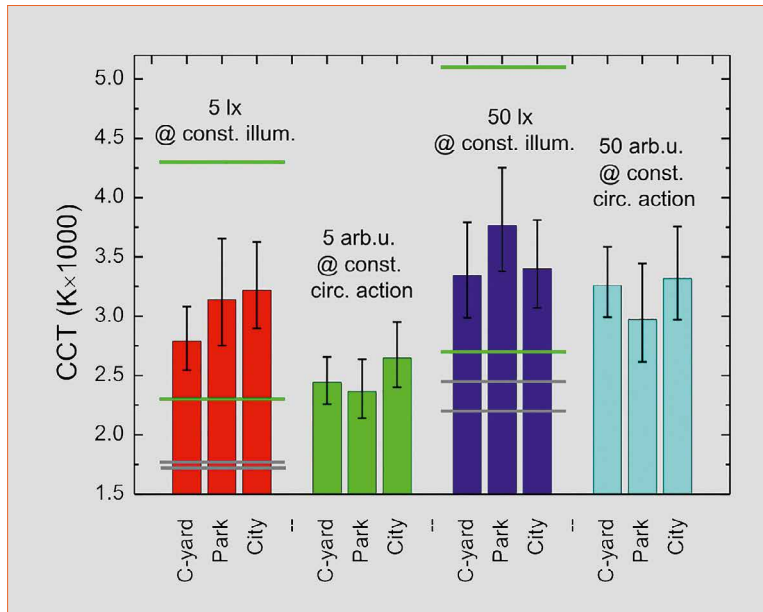

Our results qualitatively validate the Kruithof effect in outdoor environments by that with increasing the illuminance the higher CCTs are considered as “pleasing.” Furthermore the “pleasing” intervals of CCT, which can be delineated by the standard deviation of the data, seem to be much wider than the intervals defined by Kruithof at low illuminance (Figure 1 and Figure 3). In particular we can claim that the intervals of the “pleasing” CCT do exist for certain illuminance conditions and are in average the most acceptable by the subjects

in terms of pleasantness without a particular task. Complementary experiments with dimming that avoid the increase of circadian disruption showed that at low illuminance levels the illuminance is more important for subjects than the preferred CCT. Meanwhile, at higher illuminance levels, subjects tended to sacrifice some illuminance for the sake of the preferred CCT. It is worth noting that the described research results are limited to a single geographical latitude (55°N) and single cultural background of the respondents.

Conclusions

The intervals of CCT corresponding to subjectively “pleasing” illumination conditions were established for illuminances typical of outdoor environment. By performing a CCT adjustment task under constant illuminance provided by continuously tunable solid-state light engine with high-fidelity color rendition, the Kruithof hypothesis was qualitatively validated by that the subjectively selected “pleasing” CCT shifts to higher values when illuminance level is increased. However the preferred CCT was found to have much higher mean values and much wider intervals than those predicted by Kruithof. The values obtained do not significantly depend on the content and color gamut of the scene at least for a particular cultural group of subjects and geographic latitude.

In addition the constant circadian irradiation experiments showed that at lower levels of illuminance subjects tended to select CCT that is lower than “pleasing” in order to obtain higher illuminance. On the other hand, at higher levels of illuminance subjects complied with more noticeable dimming for the sake of maintaining “pleasing” CCT. ■

Acknowledgements:

The current research was performed by the staff and students of the Lighting Research Group of Vilnius University (Lithuania) with the technical support of Ledigma Ltd. (Vilnius, Lithuania) and financial support by the Lithuanian Research Council (grant number ATE01/2012).

References:

- [1] Kruithof AA: Tabular luminescence lamps for general illumination. Philips Techn Rev 1941, 6:75-73
- [2] Wake T, Kikuchi T, Takeichi K, Kasama M, Kamisasa H: The effects of illuminance, color temperature and color rendering index of light sources upon comfortable visual environments in the case of office. J Lighting Vis Env 1977, 1:31-39
- [3] Boyce PR, Bruno LD: An evaluation of high pressure sodium and metal halide light sources for parking lot lighting. J Illum Eng Soc 1999, 28:16-32
- [4] Int. Dark-Sky Assoc. Visibility, environmental, and astronomical issues associated with blue-rich white outdoor lighting, IDA, Washington, DC, USA, 2010
- [5] S. W. Lockley, G. C. Brainard, and C. A. Czeisler, High sensitivity of the human circadian melatonin rhythm to resetting by short wavelength light, J. Clin. Endocr. Metab., vol. 88, no. 9, pp. 4502-4505, Sep. 2003
- [6] Žukauskas A, Vaicekauskas R, Vitta P, Tuzikas A, Petruilis A, Shur M: Color rendition engine. Opt Express 2012, 20:5356-5367
- [7] Gall D: Circadiane Lichtgrößen und deren messtechnische Ermittlung. Licht 2002, 54:1292-1297

Making LED Lighting Solutions Simple™



We Accelerate Time to Revenue by Providing

- ▶ The Most Comprehensive System-Level Product Portfolio
- ▶ Solid-State Lighting Expertise
- ▶ Design Support Services
- ▶ Global Supply Chain and Business Solutions

 **FUTURE**
Lighting Solutions

www.FutureLightingSolutions.com

White Hybrid Light-Emitting Diodes: A Plausible Solution for Commercialization and Health Issues

One of the challenges in terms of commercialization of white LEDs is the need for cheap, inorganic phosphors. In this context, hybrid LEDs have recently emerged as a new approach based on down-converting organic coatings. The authors, Pedro B. Coto from the Institute for Theoretical Physics, Marlene Pröschel and Uwe Sonnewald from the Department of Biology, and Lukas Niklaus, Michael D. Weber and Rubén D. Costa from the Department of Chemistry and Pharmacy at the University of Erlangen-Nuremberg (FAU), describe this technology and cover recent breakthroughs and their prospects.

Nowadays, more than 20% of the total of domestic energy consumption is devoted to artificial lighting, but it is still dominated by incandescent light sources and compact fluorescent lamps. Generally speaking, although they have almost been fully developed, they are considered to be inefficient and environmentally unfriendly. Indeed, both the USA and the EU have stated that inorganic white light-emitting diodes (WLEDs) will drive the future of artificial lighting for both indoor and outdoor purposes [1]. This is based on their impressive theoretical efficiency limit of around 400 lm/W and the low-cost per lumen, which is falling a 10-fold every decade [2]. Indeed, recent market studies have estimated that over 14 billion Euros could be saved by replacing old illumination systems by WLEDs [1]. For instance, according to a McKinsey study, it is assumed that LEDs will account for 70%

of the global lighting market in 2020, which corresponds to 101 billion Euros (Figure 1) [1a]. At the same time, due to economics of scale, production costs will fall to about 32% of 2014 values by 2020 [1].

These impressive expectations have been established for monochromatic LEDs, but not yet for WLEDs, due to the use of a top coating based on inorganic phosphors (IP) like $Y_3Al_5O_{12}$; YAG:Ce³⁺ derivatives.

Figure 1:
Top: Predictions of the growth of LED luminaire with respect to unit sales from 2012 to 2018 (Source: Smallwood, Strategies Unlimited, DOE SSL Manufacturing R&D Workshop, San Diego, 2012)
Bottom: Cost distribution for high- and mid-power LED. (Source: LEDCOM model 1b)

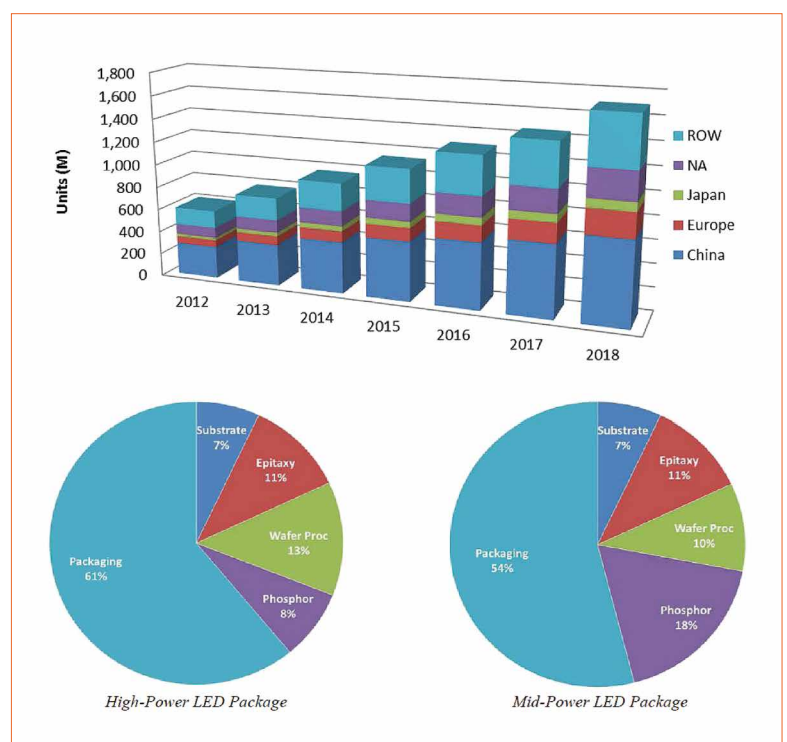

About Concerns Regarding IP Coated LEDs

The main drawbacks of IP-based coating methods are:

- High production cost due to the need of a chemical vapor deposition method
- Intrinsic high cost of the raw materials, since they are very rare
- Lack of near-infrared and/or deep-red emitters, and
- Lack of cost efficient protocols to recycle the IPs [1, 3]

Thus, problems with the IP coatings will lead to a predicted increase of production costs of IPs by 5% until 2020. This is even more critical if we consider that today the IPs account for up to one fifth of the production costs of LEDs (Figure 1) [1, 3]. A switch to organic light-emitting diodes (OLEDs) for general illumination is still not possible, since OLEDs feature only half the efficiency and about a 50-times higher price compared to LEDs on a dollars per kilo-lumen-basis as well as still having issues with the lack of recycling protocols [4]. Thus, alternative IPs and/or approaches are sought by both the scientific and industrial communities, as this route does not meet the requirements of "Green Photonics" in terms of ecological sustainability, low energy consumption, and the use of low-cost and renewable materials [1, 3].

Besides the future market issues associated with the IPs, scientists and social institutions have started to evaluate the impact of WLEDs on human health [5]. Here, the question is: are LEDs as safe as old illumination systems? This addresses both visual and non-visual effects on human health caused by the strong brightness in concert with the light spectrum of WLEDs. The visual effects involve three major considerations, namely flickering, glare, and blue light hazard [5, 6]. Going from less to more dangerous concerns, it is expected that flickering will not be very important in the future, since most of the high quality LED sources feature rectifiers and filters that effectively reduce the light flickering to almost zero. However, this could be critical for people with a risk of suffering epileptic seizures - e.g., a few seconds exposition at 3-70 Hz and susceptibility to migraines and eye fatigue - e.g., a few hours exposition at 100-200 Hz. Glare is

the second most dangerous factor if we consider high power outdoor lighting systems that can cause temporary and reversible loss of vision, damage to the eye tissues, etc. Still there are no international standards to evaluate this effect for single point sources. Finally, the so-called blue-light hazard is associated with the use of a high blue component - e.g. InGaN - in combination with yellowish orange emitting IPs that typically provides a cold white light spectrum. As a matter of fact, exposition of high-intensity blue light leads to retinal damage, such as the death of photoreceptors - i.e. necrosis and/or apoptosis - at wavelengths between 440-490 nm, and damage of retinal pigment epithelium by means of an autophagy process [6a-c]. Although our body has repair mechanisms, the photochemical damage is considered to be accumulative upon interrupted exposition times. Up to date, ANSI/IESNA RP27, CIE S009, and IEC 62471 are international standards to determine the blue-harmful light in terms of brightness, distance, number of sources, and exposition times [5, 6].

Here, the scale ranges from

- RG0 - i.e. no risk or unlimited exposition without hazard effect
- to RG1 - i.e. low risk at times ranging from 100-10000 s
- to RG2 - i.e. moderate risk at times of 0.25-100 s
- and finally, to RG3 - i.e. high risk at times lower than 0.25 s

Examples of RG2 LEDs involve indoor and outdoor lamps and luminaires with high brightness, such as automotive headlights, flash lights, frontal headlights, and some bright LED display panels. In general, many of the blue and cold white LEDs are considered RG1 or RG2, while white warm LEDs are all considered RG0. Importantly, these studies do not cover human cases like those dealing with the above-mentioned diseases, affecting children's eyes that feature a lens that is more transparent to blue and UV radiation and a macula that does not contain enough protective yellow pigments, as well as old people, whose eyes have accumulated blue-sensitive lipofuscin derivatives with age. In addition, none of the above-mentioned



WORLD CLASS POWER IN A MATCHBOX

3 & 6 WATT LED DRIVERS
CERTIFIED FOR GLOBAL USE

- RACD03 & RACD06 SERIES
- ENEC, RCM, UL, EN AND PSE CERTIFIED (CB REPORT)
- UNIVERSAL AC INPUT VOLTAGE RANGE
- 350MA TO 700MA CC OUTPUTS
- INTEGRATED INPUT FUSE AND OUTPUT PROTECTION
- CASE TEMPERATURE UP TO 75°C
- COST EFFECTIVE 3 & 6 WATT LED DRIVERS



RECOM
LIGHTING

www.recom-lighting.com

Figure 2: Representation of a commercial WLED (top) and WHLED (bottom) with organic down-converting packing coatings

studies consider the effects of lifelong cumulated exposures to blue light at both high- and low-dose exposure, as well as the effect of the UV irradiation or the lack of N-IR contribution compared to the sun light spectrum in, for instance, skin problems and/or vitamin D production.

Finally, the non-visual effects involve a change in brain chemistry induced by light exposition [5, 6d&e]. Although it is well-known that a high blue contribution in the light spectrum produces a decrease of the melatonin levels, affecting the circadian rhythms, mood, alertness, appetite, sleep quality, etc., a clear relationship with the illuminance level, the exposure duration, the timing of the exposure, and the light spectrum is not well established yet. However, it is well-known that warm white light - i.e., light with a dominant yellow, orange, and/or red contributions - is less effective in reducing melatonin than cold white light. It is important to keep in mind that, since the sun light spectrum changes over the course of a day, the human vision has become significantly sensitive to the changes in the solar spectrum - i.e. human eyes feature photopic (day), mesopic (sunset) and scotopic (dim-light) visions. As an example, our eyes are more sensitive to the blue component of the white LEDs (especially cool white LEDs) during the night.

White Hybrid LEDs as a Reasonable Alternative

Taking the above described concerns about commercialization and health seriously, it is obvious to state that although WLEDs will rule the future market [1, 3], there are clear needs to seek after new down-converting approaches to provide warm white LEDs that fulfill the green economic requirements [1, 3, 5]. In this context the potential of white hybrid light-emitting diodes (WHLEDs) sets in [7-10]. In detail, this technology

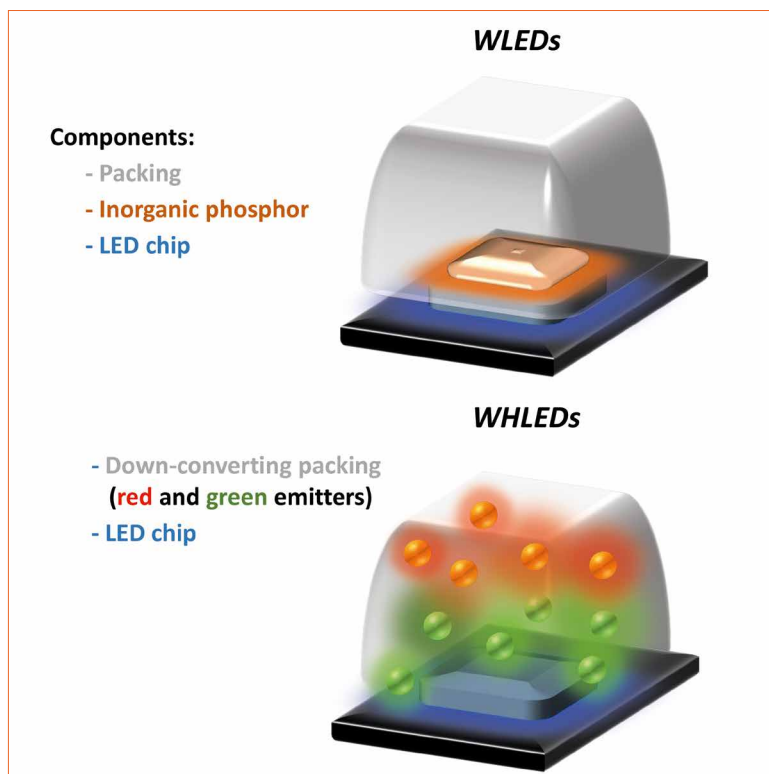

aims to replacing IPs for organic down-converting materials. Here, the WHLED architecture consists of the same electronics and emitting chips as those developed for commercial UV- and blue-LEDs, but coating or replacing the packing system with a down-converting organic compound (Figure 2). The latter is excited by the chip and the overall light spectrum of the WHLED involves both the emission of the LED (UV or blue) and the emission of the packing. Down-converting organic compounds consist of several families like small-molecules, polymers, quantum dots, coordination complexes, and most recently fluorescent proteins (Figure 3). Among them, small-molecules, polymers, and fluorescent proteins are the most interesting materials due to lack of toxicity, low-cost production/recycling, and ease of chemical design to cover all the visible and NIR regions towards mimicking the sun light spectrum.

The state-of-the-art WHLEDs designed and tested under laboratory conditions show very promising results in terms of luminous efficiencies and color quality. For instance, WHLEDs have

shown efficiency values of up to 60 lm/W with Commission International d'Eclairage (CIE) coordinates of 0.30 / 0.30, color rendering index (CRI) up to 90, and correlate color temperature (CCT) between 2500-6500 K. The only drawback is the moderate stability of around hundred hours under operation conditions. This is not totally related to the intrinsic photostability of the organic compounds, but also to their interaction with the components of the matrix chosen to encapsulate the organic compounds. Here, scientists have developed four different approaches [7-10]. In chronological order, several researchers have mixed fluorescent compounds like small-molecules, polymers, and quantum dots with matrices based on silicones and/or epoxies derivatives that require UV and/or thermal curing procedures to obtain a robust encapsulation [7a-d]. Here, only WHLEDs prepared with toxic quantum dots show interesting stabilities of at least several days [7b&d], while those with small-molecules and polymers feature only a few minutes or hours [7a&d]. As such,



瑞豐光電

2835

0.2W

0.5W

1W



Global Patent

Features

- Macadam / Energy Star standard, with high consistency;
- Optimized PPA and PCT material, with more resistant to high temperature and high reliability.
- Product specification close to the market mainstream
- LM-80 test approved
- IP free

Application

Fluorescent tube, bulb, candle light, ceiling light, grille light, down light, panel light, side light LED, high-efficiency tubes

Features

- MacAdam Ellipse, keeping color consistency
- EMC with high temperature resistance and reliability, yellowing resistance
- QFN EMC packaging type, ultra-thin, ultra-small and user-friendly design
- Pass the LM-80 test

Application

Fluorescent tube, bulb, candle light, ceiling light, grille light, down light, panel light, side light LED, high-efficiency tubes

EMC3030



SHENZHEN REFOND OPTOELECTRONICS CO.,LTD.

Add: Building #1, 10th Industrial Zone, Tian Liao Community, Gong Ming Area, Guang Ming New District, SHENZHEN, CHINA
TEL: +86-755-66839118 FAX: +86-755-66839300 E-mail: konny@refond.com

Stock Code : 300241.SZ
www.refond.com



Figure 3:

Top - chemical structures of the compounds used for developing matrices based on (a) thermal/UV curing polymers, (b) MOFs, (c) cellulose, and (d) rubber-like materials. Bottom - chemical structures of down-converting compounds, namely (e) small-molecules, (f) polymers, (g) coordination complexes and (h) fluorescent proteins

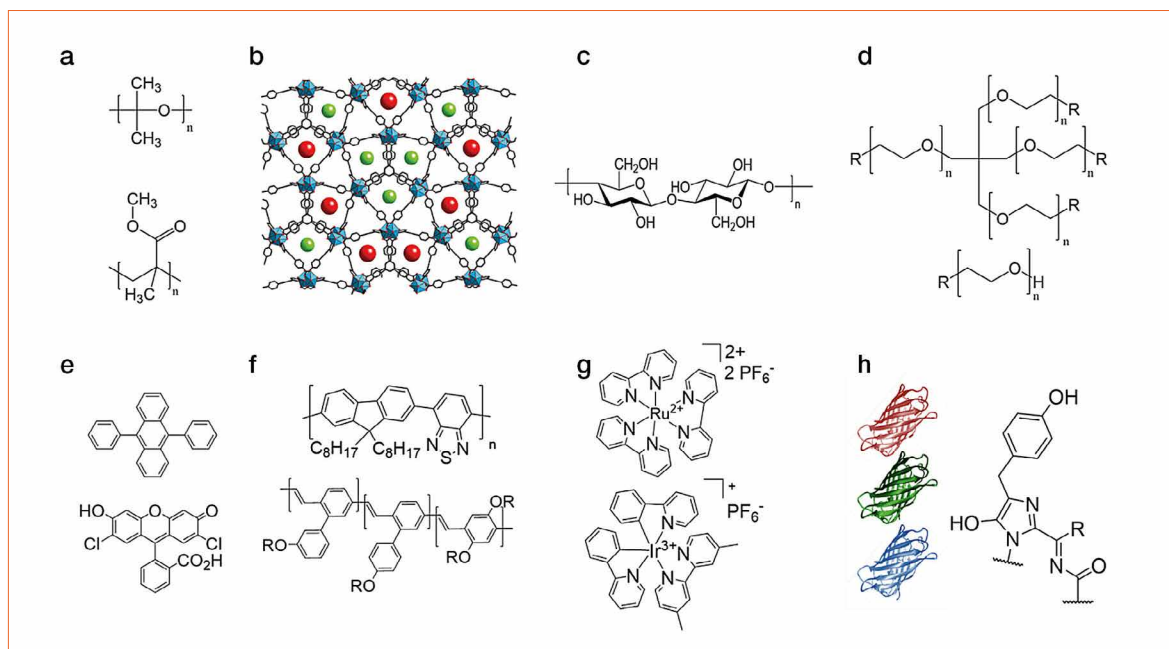

this approach has shown limitations in terms of degradation of the compounds upon preparation, phase separation issues, and lack of protocols to efficiently implement them into blue-LEDs. The most plausible approach is to previously encapsulate the organic compounds and then to implement them into the down-converting coating [7d]. The second approach involves the use of metal organic frameworks (MOFs) that show a porous morphology that allows to adsorb several mixtures of down-converting materials to cover the whole visible spectrum (Figure 3) [8]. Recently, this idea has been carried out with the use of three different non-toxic small-molecules that provide WHLEDs with CRI over 90 [8b]. This approach is easily applicable to any commercial LED and it is versatile with respect to the type of down-converting materials, but the stability in terms of luminous efficiency and color quality as well as the development of MOFs based on cheap and environmentally friendly metals still remain a challenge. Recently, several groups have developed a down-converting system based on a cellulose matrix and a mixture of blue, green, and red quantum dots [9]. The preparation of the composite is quick and facile to reproduce, but its compatibility with other materials and the stability of the

WHLED needs to be assessed to elucidate its prospect. Finally, we have recently developed a new encapsulation system that consists of mixing branched and linear polymers under vigorous stirring followed by the partial evaporation of the solvent under vacuum conditions [10]. This leads to a rubber-like material, in which any kind of down-converting material can be applied and easily recycled. Indeed, this matrix was developed to allow the use of fluorescent proteins as down-converting coating for WHLEDs. Hereafter, this new device will be referred to as Bio-WHLED. Fluorescent proteins are environmentally-friendly compounds and are easily produced by means of their expression in *E. coli*, which is a low-cost and up-scalable technique [11]. Despite these assets, the need of water-based buffer solutions and their low intrinsic stability under ambient conditions and high temperatures have hampered their use in the optoelectronic field. However, once they are embedded into the rubber-like matrix, the fluorescent proteins show stabilities of several months without affecting the features of the rubber-like encapsulation (Figure 4). Similar to the cellulose-based WHLEDs, different amounts and mixtures of the fluorescent proteins can be integrated into the rubber-like

material, but we encountered that the best results are achieved by using a bottom-up energy transfer cascade coating (Figure 4). Here, the UV- and/or blue emission of the chip is absorbed by the protein coating that further emits light at a higher wavelength. More importantly, the ratio of down-conversion efficiency - i.e. the ratio between the maxima related to the down-converting coating and the chip - can be increased up to values of 400% by means of increasing the amount of proteins or the thickness of the coating (Figure 4). The excess of emission from the first coating can be used to excite a second coating that features emission at higher wavelengths. This procedure can be repeated as many times as required to cover up the whole visible spectrum (Figure 4). In addition, it can be extended to the NIR region, since the rubber-like encapsulation features transmittance values of around 95% and refractive index values superior to 1.8 and the cascade architecture circumvent energy loss issues due to undesired energy transfer process.

In detail, the Bio-WHLEDs shown in figure 4 have been prepared by covering commercial UV- or blue-LED by a double- or triple-layer coatings - i.e. a blue LED (450 nm) and green (520 nm) / red (650 nm)

guangzhou international lighting exhibition

21st

The most influential and comprehensive lighting
and LED event in Asia

9 – 12 June 2016

China Import and Export Fair Complex
Guangzhou, China

www.light.messefrankfurt.com.cn

Contact

Messe Frankfurt (HK) Ltd

Tel: +852 2238 9969

Fax: +852 2519 6079

light@china.messefrankfurt.com



光亞 · Guang ya



messe frankfurt

Figure 4:

(a) Pictures of gels and rubber-like materials based on fluorescent proteins.

(b) Top, absorption spectra over time suggest high stability under ambient storage. Bottom, pictures of the rubbers upon UV excitation.

(c) The design of the first Bio-WHLEDs (top) and its performance under continuous working conditions (bottom)

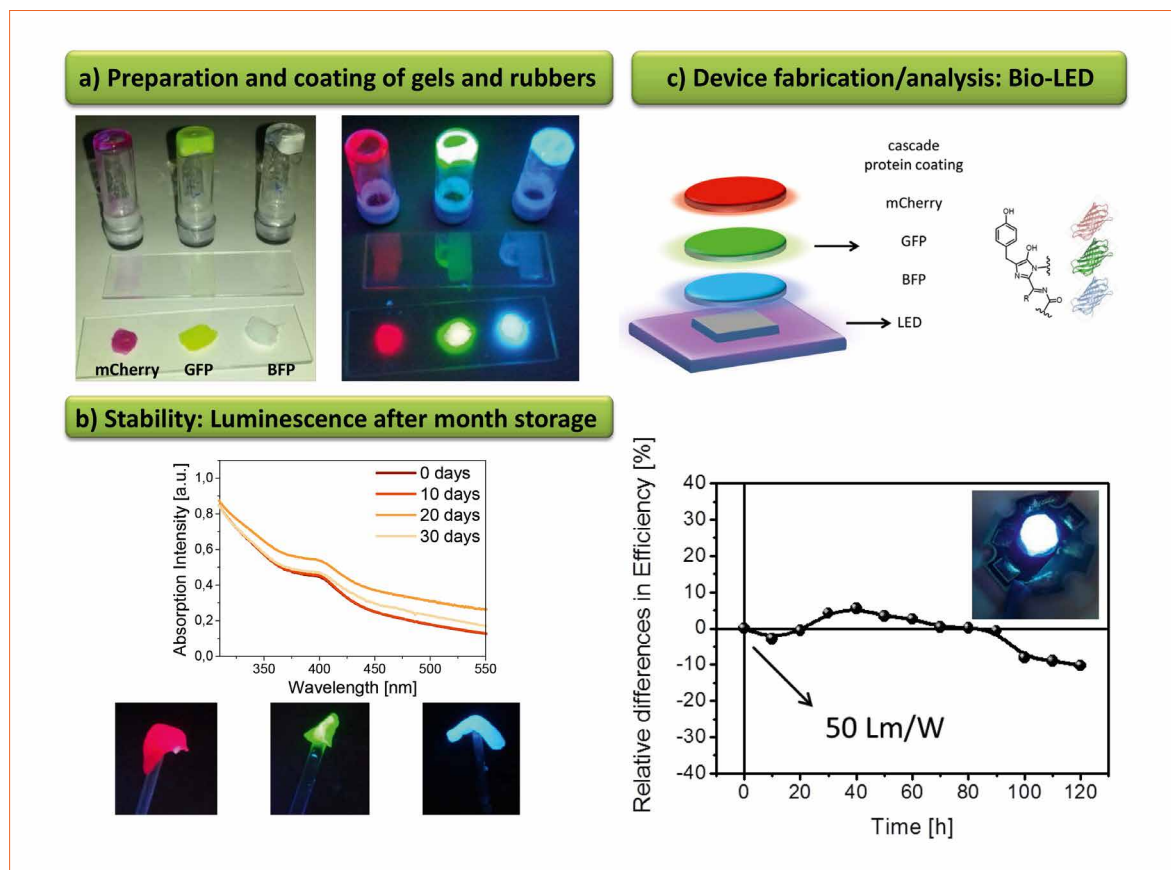

or an UV LED (390 nm) and blue (480 nm) / green (520 nm) / red (650 nm) fluorescent proteins, respectively. These devices show a light spectrum that consists of the sum of the peaks of all the components of the LED - i.e. those from the chip and the down-converting packing, providing easy-to-tune light spectrum with, for instance, CIE coordinates of 0.32 / 0.33, CRI up to 80, and luminous efficiencies of 50 lm/W.

More interestingly, the luminous efficiency and color quality stay constant over hundreds of hours with a loss of less than 10% of its initial values (Figure 4).

In view of the aforementioned, WHLEDs can be considered as an attractive approach in terms of replacing the expensive and rare IPs, resulting in a strong reduction of the total prize of the LED, and efficiently converting the blue emission of the chip to the more necessary low-energy component for developing warm white emitting LEDs that are not dangerous to human health.

WHLEDs can easily use filters and attenuators to avoid the flickering and the glare issues. Though the only roadblock seems to be stability towards the commercial implementation of the technology. This is even more critical if we consider the development of high power LED arrays, in which high temperatures are reached. To this end, two major considerations need to be addressed in the near future.

The packing system must feature:

- An easy-to-fabricate protocol without using thermal/UV curing procedures
- Low cost raw materials and recycling protocols
- High transmittance, refractive index, and mechanical robustness

The down-converting compounds must be:

- Easy and cheap to produce
- Nontoxic
- Easy to tune in terms of high absorption extinction coefficients and fluorescent quantum yields
- Thermo- and photo-stable under ambient conditions

Conclusions

Taking these considerations into account, the Bio-WHLEDs bear great potential for future breakthroughs. However, more efforts need to be devoted to circumvent the loss of color quality that is related to denaturation of the proteins and to enhance the thermal stability of both the matrix and the proteins. Currently, we are designing more thermo- and photo-stable fluorescent proteins and polymers to further enhance the performance of the Bio-WHLEDs featuring warm white emissions and even more relevant to mimic the sun light spectrum. ■

References:

- [1] a) McKinsey & Company, Lighting the way - Perspectives on the global lighting market / second edition, 2012;
 b) US Department of Energy, Life-Cycle Assessment of Energy and Environmental Impacts of LED Lighting Products, 2012; Top Sector HTSM - Innovation Contract, Lighting the future, 2013; US Department of Energy, Manufacturing Roadmap Solid-State Lighting Research and Development, 2014.
- [2] Haitz, R. et al. Phys. Status Solidi A, 2011, 17, 208.
- [3] Federation of National Manufacturers Association for Luminaires and Electrotechnical Components for Luminaires in the European Union & European Lamp Companies Federation (CELMA & ELC), The European Lighting Industry's Considerations Regarding the need for an EU Green Paper On Solid State Lighting, 2011.
- [4] a) Dehen, W. CEO of OSRAM in ZVEI: AMPERE - Das Magazin der Elektroindustrie (<http://www.zvei.org/Publikationen/ZVEI-AMPERE-1-2014.pdf>) 2014; b) Volz, D. et al. Green Chem., 2015, 17, 1988.
- [5] a) The Scientific Committee on Emerging and Newly Identified Health Risks (SCENIHR of the European Commission, Health Effects of Artificial Light, 2012. http://ec.europa.eu/health/scientific_committees/opinions_layman/artificial-light/en/index.htm#1;
 b) Martinsons, C. et al. International Energy Agency 4E Solid State Lighting, Solid State Lighting Annex - Potential Health Issues of Solid State Lighting Final Report 2014.
- [6] a) Jaadane, I. et al. Free Radic Biol Med. 2015, 84, 373; b) Shang, Y. M. et al Environ Health Perspect. 2014, 122, 269;
 c) Marquioni-Ramella, M. D. et al. Photochem. Photobiol. Sci., 2015, 14, 1560;
 d) Bonmati-Carrion, M. A. et al. Int. J. Mol. Sci. 2014, 15, 23448;
 e) Madrid-Navarro, J. et al. Current Pharm. Design, 2015, 21, 3453.
- [7] a) Huyal, I. O. et al. J. Mater. Chem. 2008, 18, 3568;
 b) Jang, E.-P. et al. Nanotechnology 2013, 24, 045607;
 c) Yoo, H. et al. Nanoscale, 2015, 7, 12860;
 d) Findlay, N. J. et al. Adv. Mater. 2014, 26, 7290.
- [8] a) Sun, C.-Y. et al. Nat. Commun. 2013, 4, 2717;
 b) Tetsuka, H. et al. J. Mater. Chem. C 2015, 3, 3536;
 c) Cui, Y. et al. Adv. Funct. Mater. 2015, 25, 4796.
- [9] a) Zhou, D. et al. ACS Appl. Mater. Interfaces 2015, 7, 15830;
 b) Tetsuka, H. et al. J. Mater. Chem. C 2015, 3, 3536.
- [10] a) Weber, M. D. et al. Adv. Mater. 2015, 27, 5493;
 b) Weber, M. D. et al. Rubber-like Material for the Immobilization of Proteins and its Use in Lighting, Diagnosis and Biocatalysis EP-1674, 15173026.4 (pending)
- [11] a) Shcherbakova, D. M. et al. Current Opin. Chem. Biol. 2014, 20, 60;
 b) Chudakov, D. M. et al. Physiol. Rev. 2010, 90, 1103.

InterLumi

The lighting fair, your local partner

Panama

"The most important event to promote the lighting industry in the region and in the world comes to Panama"

6-8 of July 2016

ATAPLA Conventions Center

www.inter-lumi.com

200+ Exhibitors
from 12+ countries
5000+ Visitors
From 20+ countries

Embedded Lighting - Developing New Lighting Applications for Modern Architectural Projects

When the era of LED lighting started, everybody talked about the new age of lighting with new opportunities. While many lighting concepts are still pure replacements of the conventional light sources, with the maturation of this technology, more and more new concepts are realized, and the future perspectives are even more exciting. Brad Koerner, Venture Manager - Philips Luminous Patterns at Philips Lighting, shows examples, explains why such new concepts are desirable, and discusses which technologies support the introduction of new lighting applications.

Many architects and interior designers have a difficult time understanding the potential for new applications of light permitted by LED technologies. Architecture is traditionally framed as a passive form set

in light - imagine an ancient stone wall illuminated by an oil-burning lamp. This mindset is perhaps best exemplified and perpetuated in modern architecture by Le Corbusier's famous quote:

"Architecture is the masterly, correct and magnificent play of masses brought together in light."

Figure 1: Hot, dangerous and fragile - the classic objectification of lighting fixtures



Man-made lighting technologies, which have historically been hot, fragile and dangerous, needed to be contained and therefore objectified, leading most designers to treat them either as architectural adornment or a nuisance to be concealed.

LED lighting technology eliminates the fundamental problems of previous electric light sources, to the point where luminous features can potentially be embedded directly into architectural walls, floors and ceilings. This ability to “embed” lighting into architectural materials challenges the lighting industry to rethink how lighting is designed, specified and fabricated.

Why Designers Would Embed Lighting into Their Walls or Ceilings

Contemporary architecture is largely based in mid-century modernism, which strove for a minimalistic aesthetic. Mid-century designers reacted against the excessive and ubiquitous ornamentation that pervaded classical architecture. Mies van der Rohe’s famous quip “less is more” expressed a desire to strip away garish ornamentation in favor of a more simple presentation of material and form. A big part of that “garish” ornamentation was of course, decorative light fixtures. The crystal, glass, intricate metal work, and warm glow that constituted classical chandeliers, sconces and pendants were tossed in favor of “invisible” light sources such as recessed downlights, wall washers, and discrete spot lights that highlighted gorgeous - and expensive - materials such as marble floors, bronze trim, and rosewood wall panels.

But in the 1970’s and 1980’s the exquisite materials of the early modernist masterpieces were dumbed-down into the bland commercial materials that came to dominate interior design: gypsum wall board, acoustic ceiling tiles, wall-to-wall carpet. Uniformity of experience came to dominate, too:

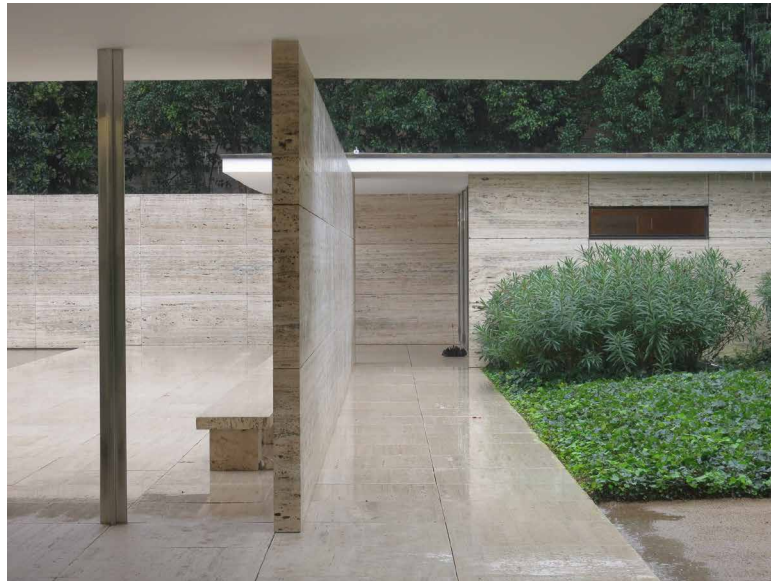

Figure 2:
Less is more - modernism stripped away decoration in favor of material and form

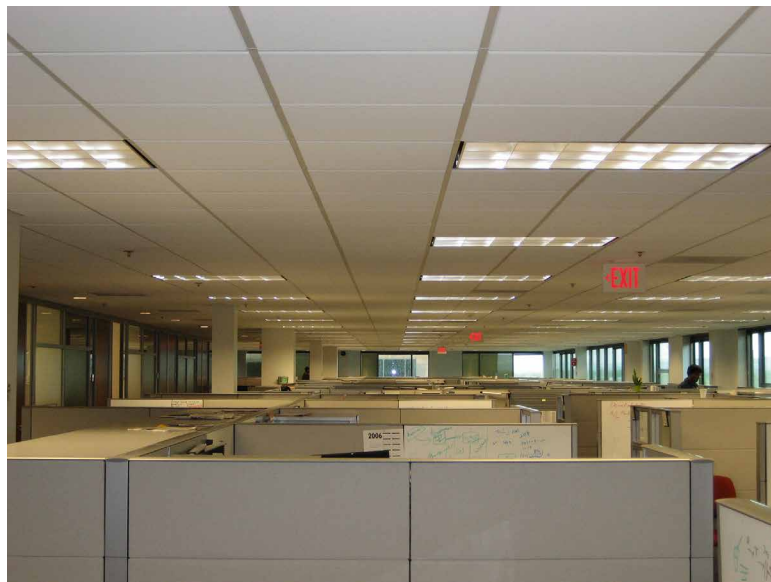

Figure 3:
The oppressive uniformity of contemporary lighting paradigms

Lighting designers became obsessed with eliminating glare and delivering constant lux levels throughout a space, throughout the day. The classical experiences of material variety, highlights and shadows, temporal changes, and subtle animation were industrialized into a homogenous, uniform, and unchanging light. The result is oppressive, unmemorable, and unattractive.

However, contemporary architects, while still largely rooted in modernism, are reinvigorating architectural design with more visual richness through use of parametric forms, geometric patterns, and innovative use of low-cost materials. In this context, embedded lighting provides a

fresh new technique with which to create innovative and eye-catching spaces.

Exploring Patterns of Light

To what effect does embedded lighting have on the experience of space? Let’s consider four characteristics of embedded light that have tremendous impact on the quality of a space:

- The style of light effect selected
- The composition or patterning of the light effect
- The dynamic animation of the luminous pattern
- The material expression of the surface



Figure 4: Sparkle and brilliance - integrating the qualities of candlelight into an architectural surface

Style of light effect

LED lighting allows for tremendous innovation in optical effects. Tiny LED sources can be discretely integrated with creative optics or with decorative shrouds either inset or protruding from the wall surface. A direct-view optic creates a feeling of brilliance; an indirect or grazing light effect creates a heightened play of shadows and texture; and a diffuse luminous surface lends itself well as a background to complicated graphic designs. The light itself can take on colors as warm as candlelight to as cool as the blue sky or as technicolor as a paint shop.

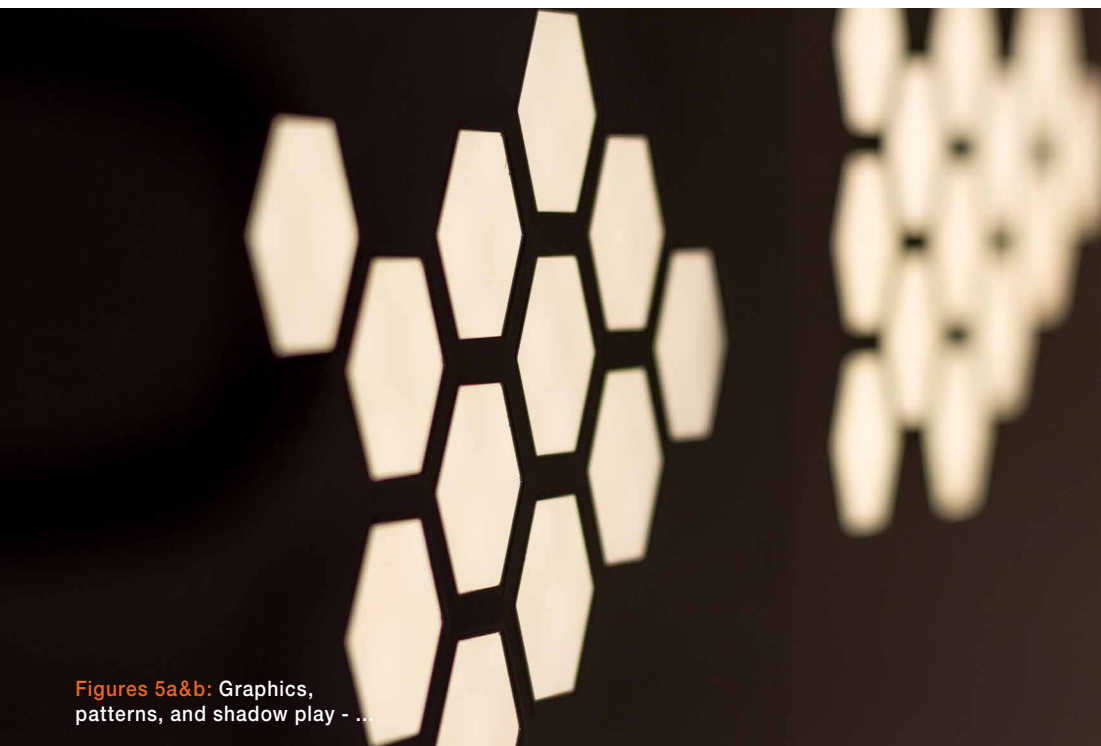

Figures 5a&b: Graphics, patterns, and shadow play - ...

Composition or patterning of light

To generate visual richness at the scale of an architectural wall or ceiling surface typically requires a panelized or repetitive surface, leading to a natural inclusion of decorative patterns. Spanning across large areas, patterns of stylish light effects makes a big impact on a space like a lobby or restaurant interior.

Dynamic animation of the luminous pattern

Humans are naturally attracted by movement, which is part of our base survival instinct. Movement creates pleasurable visual sensations: Dappled sunlight reflecting off a lake mesmerizes; flickering candlelight enchants; sequenced brilliance from a movie theatre marquee attracts us. Animation has an inherent capacity to make us feel comfortable, to make a space feel more natural and attractive.

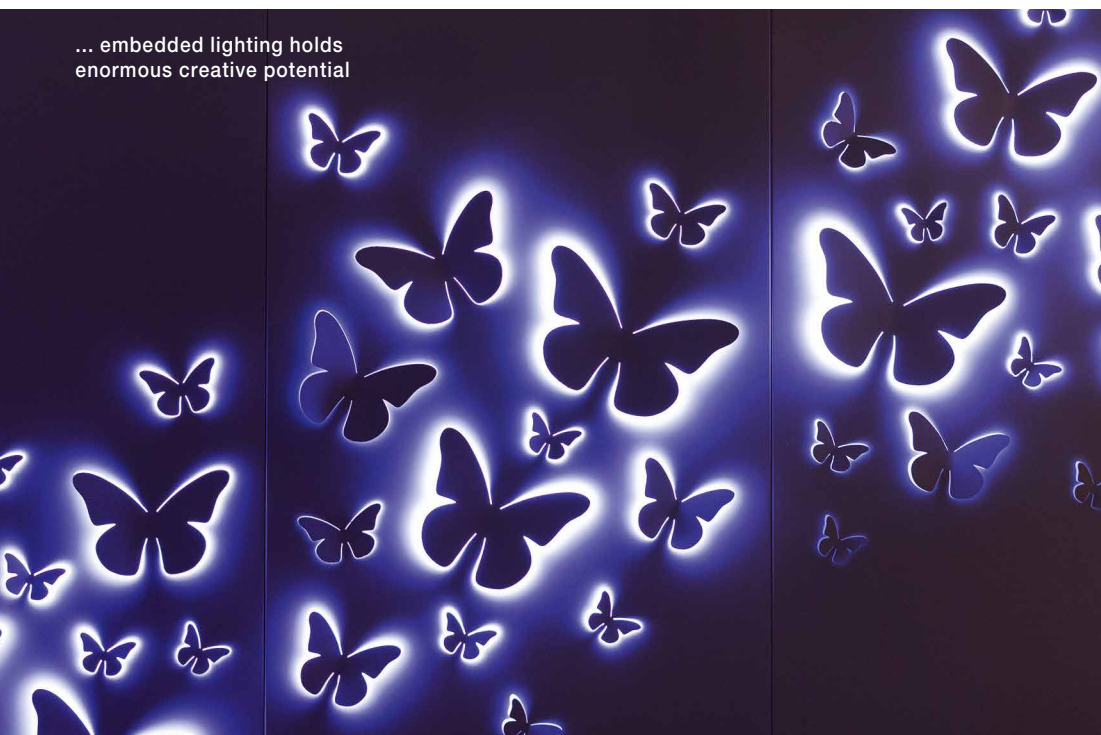

... embedded lighting holds enormous creative potential

Material expression of the surface

Embedding a luminous feature into a matte-white surface versus a glossy-black surface has a wildly different overall impact. Fusing the ephemeral magic of light plus the tactility of a material creates a whole new range of surface expressions that support many different thematic

styles and project types. Interior designers and architects gain a new tool to craft occupants' experiences of an elevator lobby, waiting room, or stylish boutique.

Mass-Customization of Embedded Lighting

In order to embrace the potential of embedded lighting, designers need a cost-effective system to visualize, specify and install complete compositions of luminous features in architectural surfaces.

The architectural design and construction process is largely adopting a digital workflow, with a growing portion of buildings being designed and built using building-information-modeling ("BIM") systems. BIM allows for complex architectural systems to be precisely designed, visualized with photorealistic accuracy and efficiently detailed for construction. And beyond BIM, leading architects are increasingly turning to a technique called "parametric" or "generative" design to create the wildly expressive sculptural forms found in so many of the world's signature architectural projects.

The architectural lighting industry is also transforming by largely adopting a "just-in-time" lean production workflow. Lean principles have demonstrated radical improvements in the manufacturing

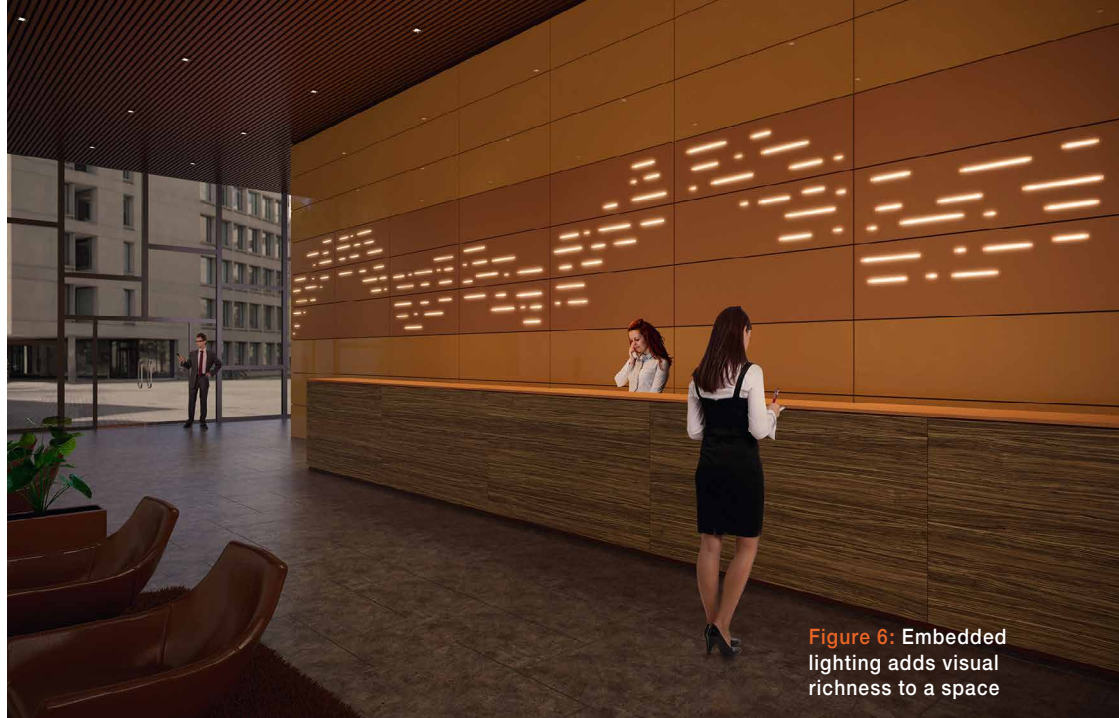

Figure 6: Embedded lighting adds visual richness to a space

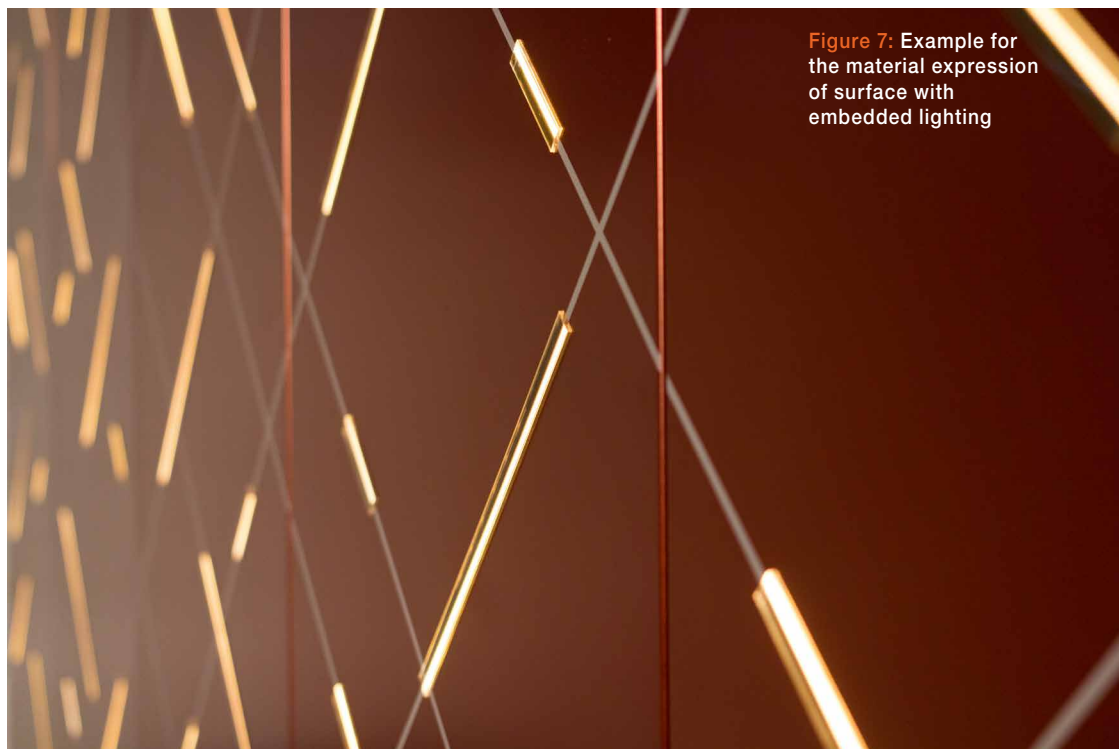

Figure 7: Example for the material expression of surface with embedded lighting

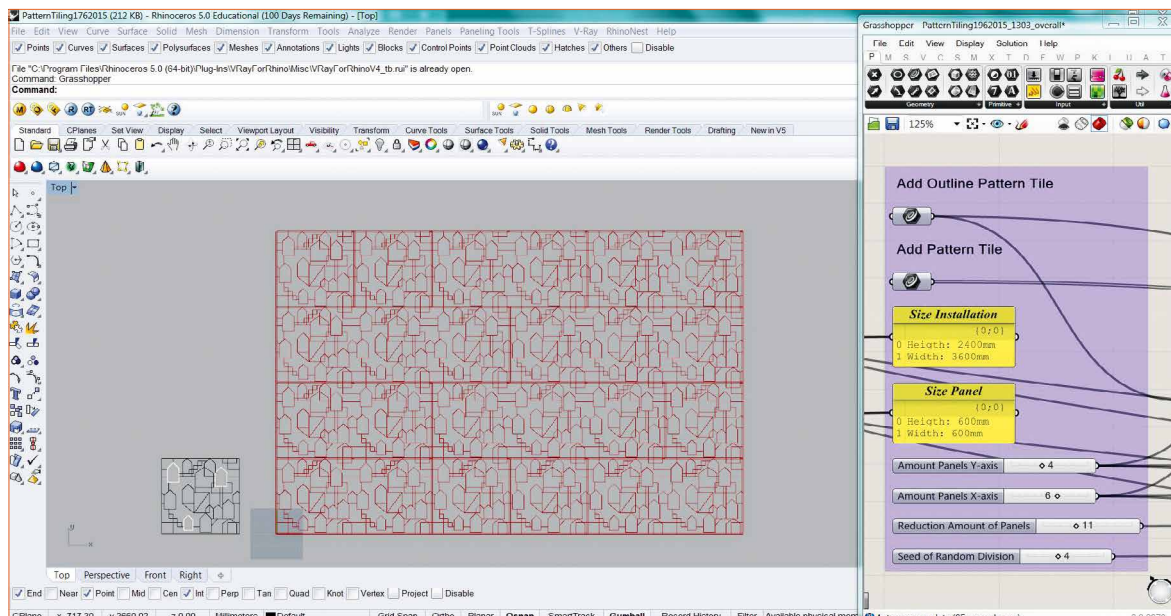

Figure 8: Parametric design - Rhino Software with Grasshopper plug-in, modeling a repetitive tiled pattern of embedded lighting

Figure 9: Mass-customization - laser cutting is a common digital production process that enables parametric design

laser cutting

sector, effectively producing products with short lead times only once an order has been placed. No longer are products built for inventory, and variation in product lines can be readily accommodated without huge carrying costs. And beyond lean, digital fabrication techniques such as CNC laser cutting, digital printing, 3D printing, etc. are, in effect, “turbocharging” lean production by producing endless variations of products.

Digital fabrication systems in lean production flows align readily to the core notion of parametric design - that design, engineering or production constraints can be parametrized and coded into easy-to-use software tools that can generate wild variety with little effort. If a product system is designed with key parameters varied directly through digital fabrication, customized design effectively adds zero cost to the end product.

Future Production Technologies for Embedded Lighting

LED lighting can already be incorporated into digital production systems in a variety of ways.

One common example is fixing standard LED light nodes in architectural panels that are digitally fabricated via subtractive CNC cutting.

Looking toward to the future, it is readily conceivable that the actual LED light engine and associated electronics could be additively fabricated directly into architectural panels; plus the panels themselves may be digitally fabricated. Such a combination will allow for wild architectural forms with lighting systems seamlessly integrated.

For example, on the light engine side of the solution, technologies such as conductive inks and conductive adhesives are advancing fast enough that printed electronics are quickly becoming practical for production volumes. As with all the advances in digital printing technologies, printed electronics hold the promise of both digital customization and high-volume, low-cost production.

Another example of light engine innovation is the field of “e-textiles”, where conductive traces are woven into various types of fabrics. Many types of fabrics are already

used in architectural interiors and exteriors. It seems a natural opportunity to add lighting to fabric surfaces.

On the architectural side of the solution, there are many recent examples of architects and engineers exploring CNC production technologies for building structures and surfaces. CNC milling of decorative interior architectural panels has been available for many years. CNC milling of formwork is already commonly used in the creation of large-scale fiberglass panels. The more avant-garde researchers are testing large-scale 3D printing of concrete. There have even been experiments of in-situ CNC woven structures of fiberglass or carbon-fiber strands to create gorgeous new styles of architectural surfaces.

To reiterate: Many of the best innovations in the lighting industry are coming from outside the industry. Robotics, ship building, textile production, digital printing - innovators should cast a wide net to find the next architectural lighting innovations.



Figure 10: Embedded lighting profoundly impacts the way people feel in architectural spaces

Creating a Complete System for Embedded Lighting

There are numerous challenges and opportunities the industry faces in driving the acceptance of new lighting applications.

Fighting the “paradox of choice” will be a key area of innovation. From a marketing and sales perspective, if you provide a customer too much choice, they are paralyzed in making a decision. How do you help your customers quickly and efficiently find or create exactly what they want?

Embedded lighting systems must integrate directly into architects’

existing design and engineering work flows. Due to its fundamental nature as an architectural system, embedded lighting needs to be directly fused into the BIM design process and the more advanced parametric design processes. How do you develop lighting systems natively in BIM?

The true potential of embedded lighting is in the dynamics associated with digital control; but if the industry can’t reduce the overall project costs of these offerings, they will remain forever a luxury feature for only the most high-end projects. How do you efficiently simulate, specify, program and commission cloud-connected, embedded lighting systems?

Conclusion

When dynamic lighting fuses into the material surfaces of a space, it has the potential to make a profound impact on the way people feel, the way they act, the way they interact with others, the way they interact with the space itself. Such “embedded lighting” has the potential to tell stories; it has the potential to make a statement with unique visual attraction in a multitude of applications. Embedded lighting breaks through the tired paradigms of light bulbs and light fixtures and opens up exciting new opportunities for both the design and delivery of architectural lighting systems. ■

Light Flicker from LED Lighting Systems - An Urgent Problem to Solve

Flicker is the modulation of a lamp's light output caused by fluctuations of the mains voltage supply. Recent research has shown that fluctuations of short wavelength emissions are perceived to a higher extent and light flicker may have a huge influence on the well-being of end users. Prof. Georges Zissis, Head of Light & Matter Research Group at the LAPLACE Université de Toulouse presents and discusses the influence of driver topologies, research results, metrics and standards.

Light flicker is one of the so-called Temporal Light Artefacts (TLA) defined as undesired changes in visual perception induced by a light stimulus whose luminance or spectral distribution fluctuates with time for an observer in a certain environment. The second TLA is the stroboscopic effect. Light flicker combined with rotating, moving parts or spatial patterns may be responsible for stroboscopic effects. Stroboscopic effects might induce hazards to workers in proximity to rotating machines and tools. The typical frequency range in which the stroboscopic effect is perceived is from 80 Hz up to 2000 Hz.

With the ever-increasing penetration of light emitting diode lamps in more applications and considering that their mode of operation differs from the legacy technologies, one might expect that light flicker would disappear.

Recent investigations show that some LED lighting products may exhibit anomaly high flicker rates, especially under dimming conditions. While today there are no mandatory regulations, there are some stringent recommendations. This is an important item for both consumer satisfaction and consumer acceptance of Solid State Lighting products.

Light Flicker and its Impact on Health and Well-Being

Light flicker has always been an issue for lamps with possible important health impacts. There are more conditions that are supposed to be sensitive to flicker but regardless of how much they correlate to this, everyone would like to see it minimized. It isn't uncommon to hear people in offices complain about headaches and dizziness brought on by fluorescent lamps with magnetic ballasts [1, 2]. In fact, research has shown that fluctuations of short wavelength emissions are perceived to a higher extent [3, 4].

It is known that exposure to light flicker (in particular at frequencies between 3 Hz and 55 Hz) can cause photosensitive epileptic seizures in various forms, depending on the individual and his visual pathology, the contrast, the wavelength and the viewing angle or distance. Approximately 1 in 4,000 humans suffer from photosensitive epilepsy. Women and elder people are more sensitive to flicker than men and younger people.

Furthermore, it is known that people who suffer from migraines are more likely to be sensitive to flicker.

In addition, flicker may have serious consequences for people suffering from specific medical conditions.

On the opposite side, pulsed lights may also have some positive effects: it has been reported that the pulsed operation of lamps could offer opportunities for energy savings according to the Broca-Sulzer effect [5, 6] due to enhanced perceived brightness. Thus, it is argued that energy savings can be achieved by using pulsed LEDs at a very high frequency. In that case it is absolutely necessary to understand the influence of flicker on humans in order to avoid any deleterious effects appearing with products using that type of pulsed light.

Definitions, Measurement and Origin of Light Flicker

Light flicker refers to quick, periodic changes in the lamp's light output based on the "luminance contrast modulation". Light flicker is due to fluctuations of the absorbed electrical power mainly due to fluctuation or modulation of the mains voltage. As the mains frequency in Europe is 50 Hz the light flicker is expected at 100 Hz (120 Hz, if the mains frequency is 60 Hz).

Referring to figure 1, there are two widely accepted methods for defining light flicker [7]:

Flicker Modulation (or percent flicker): it takes the maximum and minimum luminance values (respectively L_{min} , L_{max}) of the fluctuation and performs the following calculation:

$$F_m [\%] = 100 \cdot \frac{L_{max} - L_{min}}{L_{max} + L_{min}} = 100 \cdot \frac{|\Delta L_{min}|}{L_{max} + L_{min}} \quad (1)$$

Flicker Index: it requires the calculation of the areas of "zone 1" and "zone 2" situated above (S_{z1}) and below (S_{z2}) the average luminance as defined by its RMS value (L_{av}).

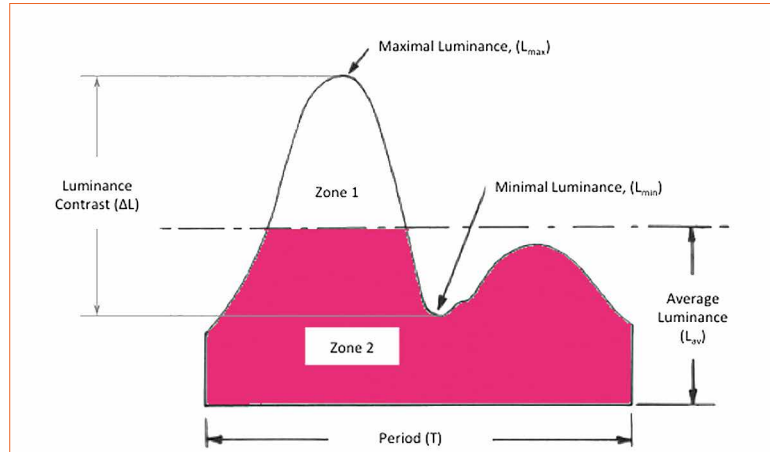

Figure 1: Light flicker definition

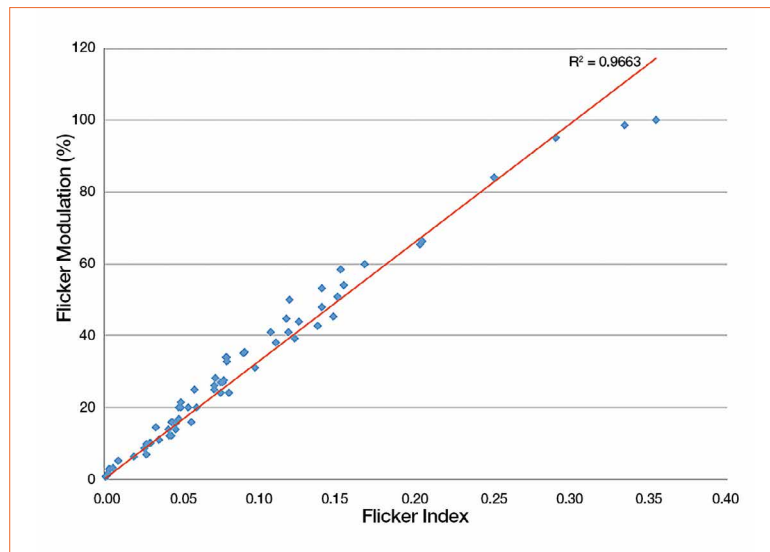

Figure 2: Experimental correlation between Flicker Modulation and Flicker Index (R2 is the least square determination coefficient)

$$FI = \frac{S_{z1}}{S_{z1} + S_{z2}} \quad (2)$$

Both approaches are used in lighting. In fact Flicker Modulation metrics is accurate only in the case of periodic signals and doesn't take the waveform of the light variations into account. On the contrary, Flicker Index accounts for obvious differences in waveform shape and can be used in fully aperiodic signals. Flicker Index is higher when rising and/or falling fronts are steep, Flicker Modulation can't show this effect. As Michael Poplawski [8] said "percent flicker is extremely simple to determine - requiring only the measurement of maximum and minimum values with respect to a reference and simple math. Flicker Index, on the other hand, requires the accurate measurement of waveform shape with respect to a reference and much more complex integral math".

For the moment there is not any formal proof that, for periodic light variations, one or the other metrics is considered as more accurate for describing the flicker perception by the end user. Furthermore, Kitsinelis et al [9] showed that, in the case of sinusoidal-like signals found in the large majority of electrical lamps there is a strong correlation between Flicker Modulation and Flicker Index; Figure 2 illustrates this finding. Assuming that Flicker Index is zero when Flicker Modulation is null we can obtain the following relation:

$$\frac{F_m}{FI} \approx 3.3 \quad (3)$$

In the above relation F_m is expressed in decimal value not in percentile.

As has been mentioned in the above paragraphs the light flicker definition is based on luminance contrast modulation (or variation in general).

Figure 3:
Experimental set-up for light flicker measurement in LAPLACE laboratory

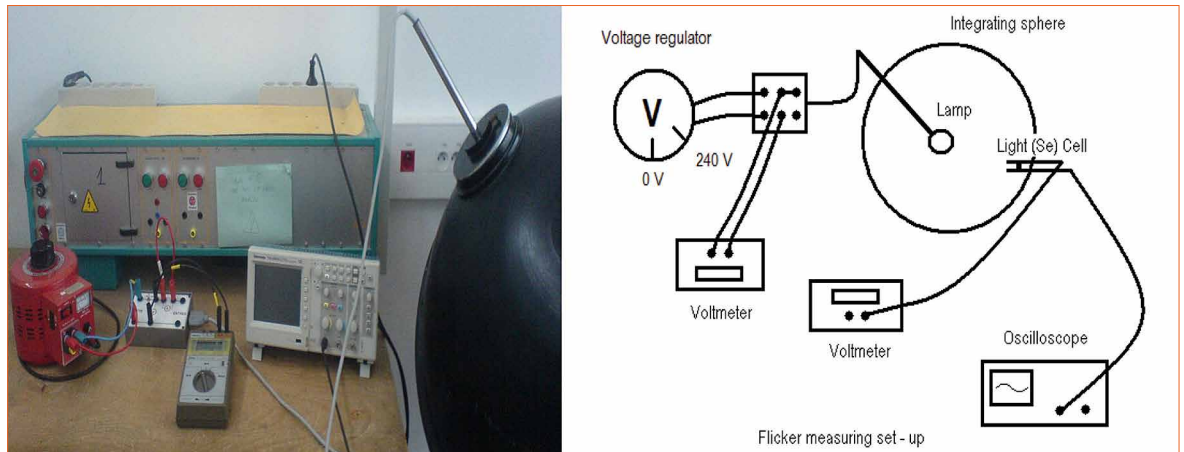

However, luminance measurements are rather difficult to carry out. For this reason Zissis [10] proposed to measure light flicker based on luminous flux time variation instead of luminance contrast modulation. This is a good approximation because it smooths the spatial variation of the light emitted by the lamp. The measurement can then be carried out using an Ulbricht integrating sphere equipped by a time resolved light detector.

Figure 3 shows the original set-up at LAPLACE laboratory in Toulouse. This is a very robust way to evaluate light flicker. In this primitive version of the set-up an Ø80 cm integrating sphere was equipped with a selenium cell as a photo-detector coupled to a Tektronix 2002B oscilloscope for detecting and recording the light waveforms and a true-RMS voltmeter for measuring the average light output (in millivolts) independently. The selenium cell has a rather slow answer and thus only low frequency flicker can be detected (up to 1 kHz). Since then the photo-detector was replaced by a rapid photodiode (SLD-70BG2) coupled with a logarithmic amplifier in order to resolve light flicker at higher frequencies (up to 100 kHz).

To compare the light flicker behaviour of different technologies (especially LED omni-directional lamps and LED spots) a 100 W A-shape incandescent lamp has been used as reference. The reference lamp exhibited a 10% Flicker Modulation value at 100 Hz, the light signal was very close to $\sin^2(2\pi ft)$ shape. This is perfectly logical. Light fluctuation in an incandescent lamp is, in fine, due to the variation of filament temperature within a full AC-period; the temperature depends on the Joule heating which is proportional to $\sin^2(2\pi ft)$ and light emission follows Stefan's law proportional to the 4th power of the filament temperature (thus a small variation within an AC-period is responsible for measurable luminous flux variations at twice the mains frequency). This amount of light flicker at 100 Hz is not perceivable by the human eye.

LED flicker characteristics are primarily a function of the LED driver. However, LEDs have to be driven in DC-current; so, in theory light flicker should be missing. However, a LED lamp uses a driver (CIE official vocabulary imposes the use of term "ballast" instead of

"driver") that is interfacing the LEDs inside the bulb to the mains plug. Figure 5 shows simple schematics of LED ballast generic architecture. Light flicker is then linked to two facts: (1) residual ripple after the rectifier-filter stage and (2) final stage converter architecture.

Residual ripple is responsible for light flicker at a frequency of twice the mains, whereas, converter architecture usually leads to high frequency flicker (several tens of kilohertz). Low quality, low price, ballasts using passive filters are usually responsible for high light flicker. As US-DoE mentioned [11], a low cost requirement for a small integral LED lamp may force a fundamental trade-off between flicker and the power factor. Add to that, that very often, passive elements used as filters (for instance chemical capacitors) have a low lifespan and a huge impact on the environment [11]. All in all, a large amount light flicker at 100 Hz constitutes a serious indication that ballast quality and reliability are probably unacceptably low.

Dimming a LED source can increase or induce flicker, most notably when phase-cut controls are used and/or pulse-width modulation (PWM) is employed within the driver to reduce the average light output from the LED source.

It should be noted that Kitsinelis et al [13] proposed a very effective way to detect light flicker using the camera of a cellular phone.

Figure 4:
Schematics of usual LED ballast architecture

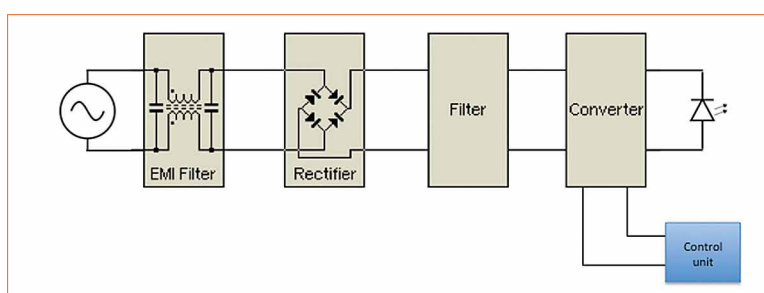

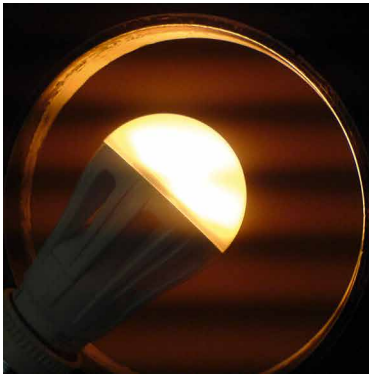

Figure 5: Flicker detection using the built in camera of a cell phone obtained by LAPLACE. Flicker leads to the appearance of dark fringes on the image

Figure 5 shows the obtained results by this method. The simplicity of the method allows its use by the general consumer: just use a smart phone with an integrated camera, target the lamp and look at the phone screen. If striations appear around the lamp (dark fringes), then flicker is present. The spatial frequency of the fringes is related to the flicker frequency and the frame rate of the camera. The contrast between the fringes is a straightforward estimation

of the Flicker Modulation. Generally speaking, when fringes are visible Flicker Modulation is higher than 20%. Large fluctuations (i.e. large flicker) are clearly recorded as striped images on the smartphone display. The stripes tend to fade with lower Flicker Modulation but they can still be detected by fine-tuning the camera settings such as the exposure. Lamps that show no flicker or very small fluctuations will be seen with no fringes on the display and the recorded images.

This easy and quick flicker test with such a widely available tool as a mobile phone may prove useful to consumers seeking to avoid the undesirable effects of flicker even at such non visible frequencies.

Light Flicker Measurement Results

Globally, 26 lamps (LED, but also CFLs) have been tested with this device under real operating conditions (230 V 50 Hz pure

ELT Wireless technology solutions

Enlight about our last releases in wireless control technologies for indoor and outdoor lighting applications!

Outdoor

Wireless street lighting management solution

light+building

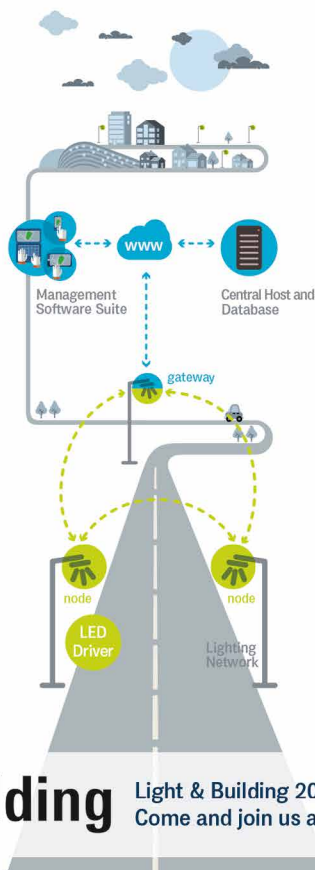

Indoor

Bluetooth 4.0 smart wireless control unit for lighting control gears

Light & Building 2016 approaches. Come and join us at our booth 4.0 B80!

eBLUE

Switch to Smart

Sync. via cloud

ELT elt@elt.es www.elt.es

Figure 6:
Luminous flux variation
waveforms for CFL (1st
line) and halogen lamps
(2nd line) and LED lamps
(3rd and 4th lines)

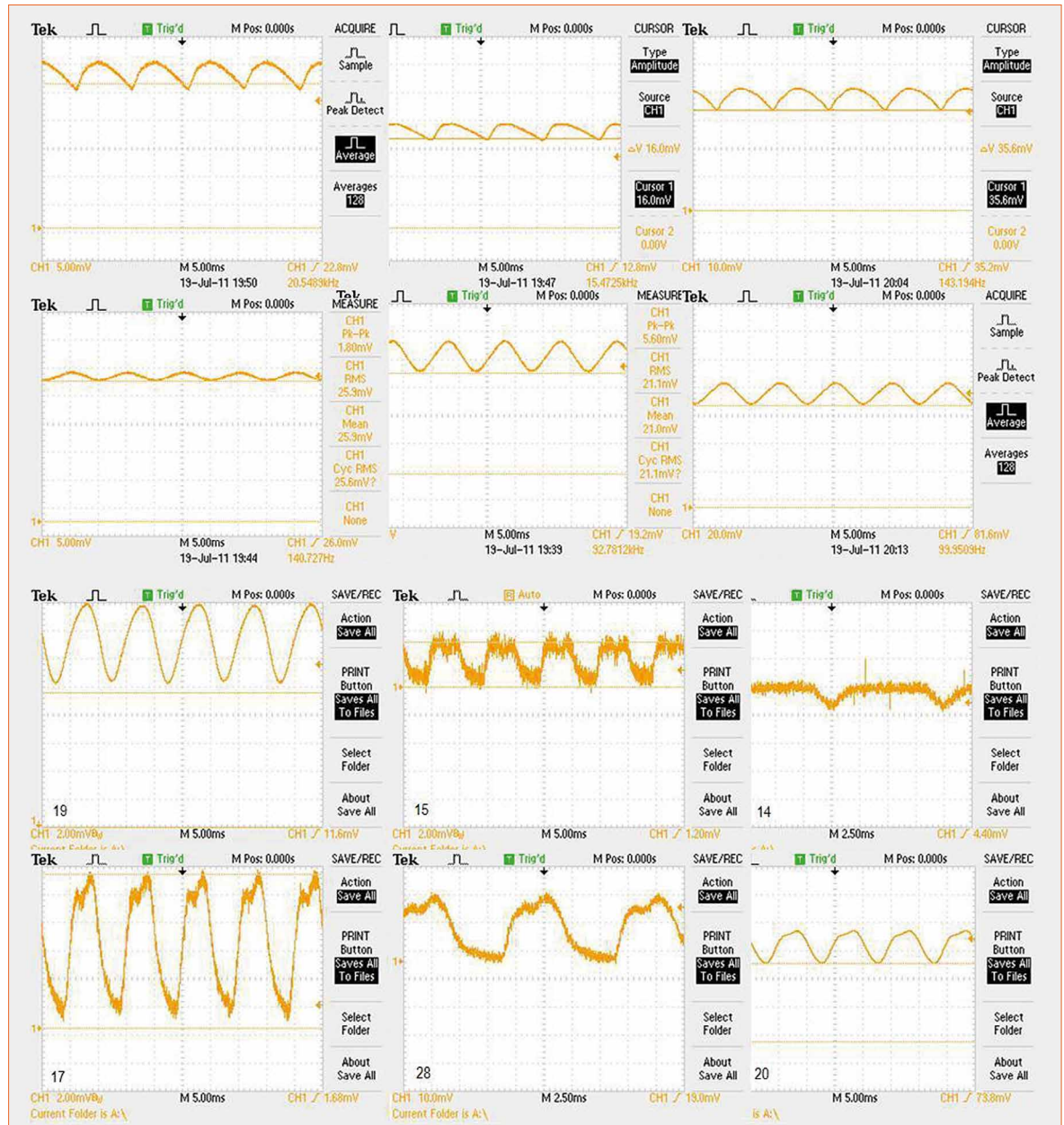

sinusoidal stabilized voltage feeding). Figure 6 shows a sample of the results.

While all CFL and incandescent lamps exhibit smooth flicker behaviour as expected, the tests show that LED lamps have different behaviours ranging from zero flicker, to high flicker content (up to 100%). Moreover, the waveforms of the light output fluctuations are not as smooth and symmetrical as the ones for CFL and halogen lamps. This last is a clear indication that various LED lamps use different converter architectures.

Figure 7 shows the experimental Flicker Modulation values for

some tested lamps at nominal operating conditions.

Very recently, Kukačka [14] also observed that flicker behaviour could change with the lamp operating time (e.g. lamp warming). Figure 8 shows our measurements (photodiode current and its FFT) for a LED lamp immediately after switching on and 20 minutes later (the lamp was operating at fix ambient temperature 25 ± 0.5 °C). We suspect here that some ballast components are sensitive to temperature increases; this is not a good sign for ballast quality.

It should be noted that a 100 W incandescent lamp has a flicker

percentage of 10% and good quality CFLs may reach a per cent flicker of 20%. In both cases end-users don't notice any flicker, thus we can consider that up to a Flicker Modulation of 20%, flicker is acceptable (the next paragraph of this paper contains a more detailed discussion of flicker perception). Thus, looking at figure 7 we conclude that many products sold today in occidental markets are subject to high flicker rates at low frequencies.

The tests also show that for LED lamps exhibiting flicker, a voltage decrease (dimming), induces, in many cases, more flicker. Figure 9 gives the results for some

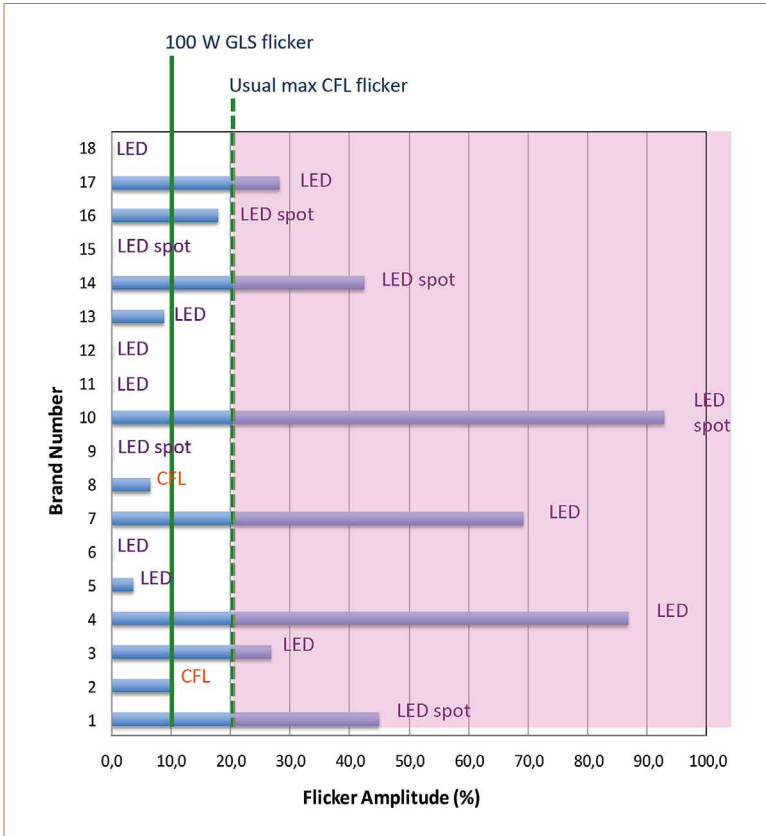

tested LED lamps. As can be seen, in infrequent cases Flicker Modulation stays constant when voltage drops (lamps n°10 and 17), then the lamp switches off at an approximate voltage lower than 100 V.

Figure 7: Some experimental percentage flicker values of various lamp technologies as obtained in LAPLACE laboratory

Flicker Perception

Following DoE [11], when discussing the potential human impacts of flicker, it is important to understand the difference between sensation and perception. Sensation is the physiological detection of external conditions that can lead to a nervous system response, while perception is the process by which the brain interprets sensory information.

For many years it was generally accepted that people cannot notice light flicker if its frequency is higher than the eye fusion frequency (e.g. 70 Hz). However, recent research has shown that fluctuations of short wavelength emissions are perceived to a higher extent. For example, people suffering from migraines are more likely to be sensitive to flicker at high frequencies [15]. The main issue here is how people perceive flicker and if they accept it or not. This question is difficult to answer because flicker perception is a real multi-parametric effect.

Figure 8: Light Flicker from a LED lamp measured by the photo-induced current in the detecting photodiode (upper plot) and its FFT decomposition (lower plot) just after switching on the lamp (blue line) and after 20 minutes of operation (green line)

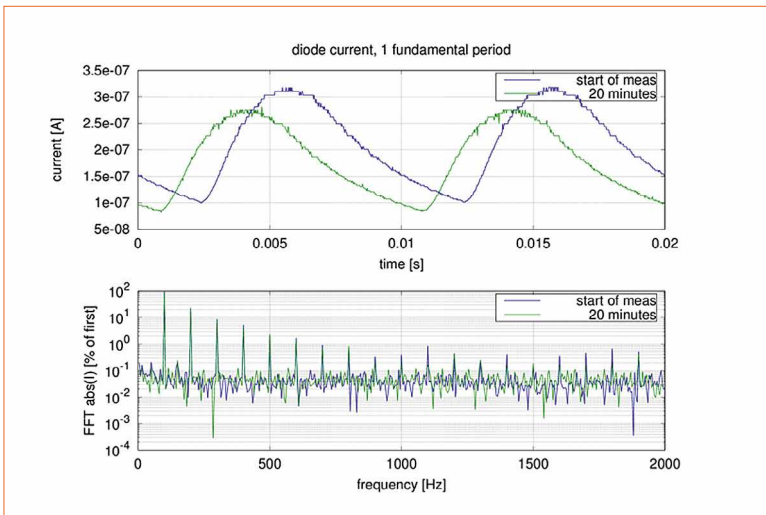

Bullough et al [16] studied the flicker perception based on two parameters: the flicker frequency and the flicker depth at constant 50% duty cycle. The visual task used to assess flicker perception was waving a light-coloured rod against a dark background and represents close to a worst-case scenario for detection of stroboscopic effects.

Figure 9: Flicker modulation for LED lamps (numbered from 10 to 20) under dimmed voltage input

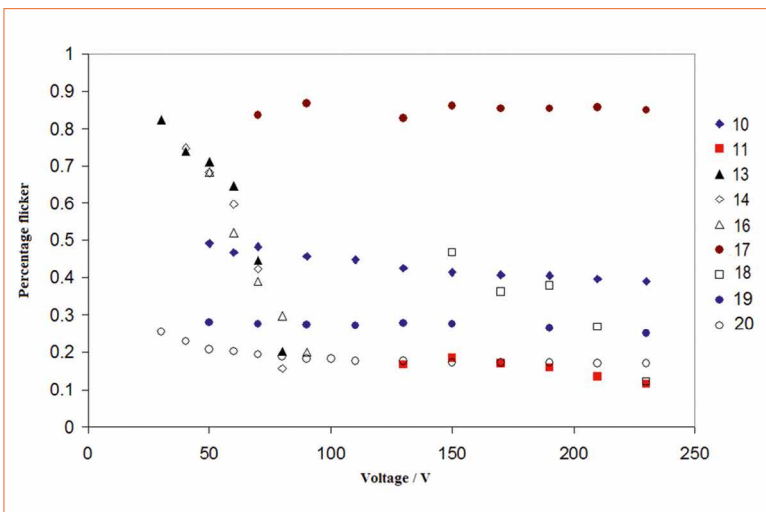

For rectangular waveforms operated so that the maximum light output is produced 50% of the time and the minimum light output is produced 50% of the time, the percent likelihood of detection can be estimated as follows:

Figure 10: LAPLACE experiment for studying flicker perception

$$d [\%] = 100 \cdot \frac{25 F_m + 140}{f + 25 F_m + 140} \quad (4)$$

where f is the flicker frequency (in Hz) and F_m the Flicker Modulation (in %). This equation is applicable to frequencies from 100 Hz to 10 kHz and for Flicker Modulation values from 5% to 100%.

To assess acceptability of flicker producing noticeable stroboscopic effects, a five-point scale was used. The results suggest that even when stroboscopic effects from flicker were readily detected, they were not always judged as unacceptable. The acceptability rate, a , can be estimated using the following empirical relation:

$$a [\%] = 2 - \frac{4}{1 + (f/f_b)} \quad (5)$$

where f is the flicker frequency (Hz) and f_b the borderline frequency (Hz) between acceptability and unacceptability, that can be given as follows:

$$f_b [Hz] = 130 \log(F_m - 73) \quad (6)$$

Arexis et al [17] in LAPLACE laboratory designed a new experiment in order to understand the influence of the frequency combined to the duty cycle (Flicker Modulation depth is also studied).

A black box (Figure 10) was placed in a dark room and a High Brightness warm white LED (3000 K) module placed behind a frosted glass plate and never seen directly by the observer. The LED module, supplied with rectangular current

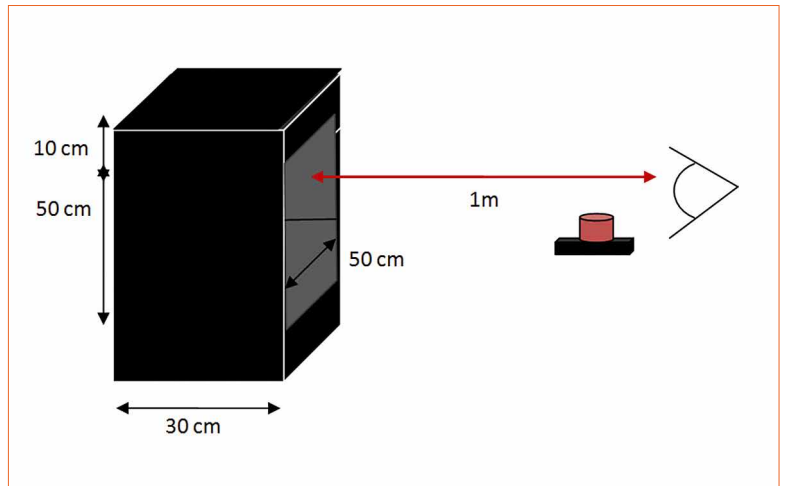

pulses generates 540 lm and an average illuminance of 167 lx on the background observed surface. Background surface colour can be either black or white; the experiment has been carried-out with both colors. During the experiment the frequency was varied between 50 to 70 Hz and the duty cycles from 20% to 90%, in all experiments the average illuminance was kept constant.

The observers enter the room and sit 1m from the edge of the light box. They could not directly perceive the light source or the diffuser. We asked the observers to look directly at the background of the box in front of their visual axis and to not move their heads. We then performed 40 lighting scenarios with duration of 5 seconds each. After each one we asked the observers to push a button if they perceived or felt light flicker. No other action was required.

The number of positive answers for perception of flicker is shown in figure 11. For lower duty cycles

and lower frequencies the flicker was more easily detected. As for the different backgrounds, we see that with a white background the volunteer detected flicker for a larger range of frequencies. The fluctuations are more easily perceived with a white background due to increased luminance contrasts. Because of that we noted that the visual fatigue of the participants is also higher with the white background than with the black background.

Furthermore, we wanted to know how the volunteers perceive the most extreme LED flicker cases that we found in our tests (100 Hz, more than 90% flicker). So we ran two lamps side by side in two similar light boxes. One of them was operated in DC mode with no fluctuations and the other was programmed to run with pulses at 100 Hz and a duty cycle of 50% thus giving us a 100% flicker. Both black and white background were used again. The average power was kept at 2 W.

Figure 11: Flicker perception (number of positive answers) with black background (left) white background (center) and comparison between the two colors (right)

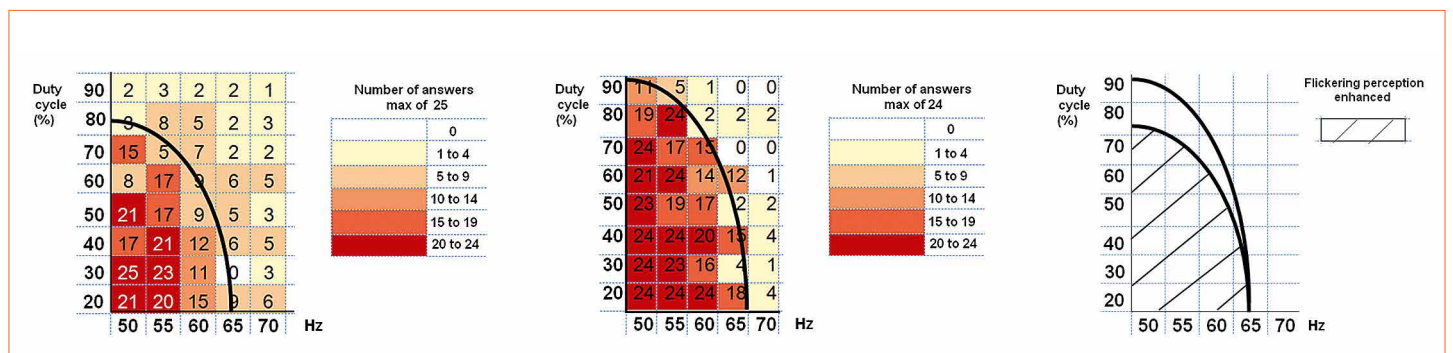

The results were the following:

- With both black and white background 16 out of 16 volunteers noted that the pulsed LED was brighter (Broca - Sulzer effect)
- 15 out of 16 volunteers did not perceive a light fluctuation with any background colour. More especially, 8 out of 8 did not perceive a fluctuation with the white background and 7 out of 8 volunteers did not perceive a light fluctuation with the black background (the one that perceived it was correct in identifying the pulsed lamp)
- When both lamps were set to pulse (100 Hz, 50% duty cycle) with different backgrounds then all our volunteers agreed that the white background gives a higher brightness impression, and two noted a fluctuation with the black background

There are two important points here. The first one is that the pulsed operation of LED lamps can indeed give us energy savings if people perceive them as brighter for the same power input. The second point here is that although in our visual perception experiment the white background made it easier for flicker to be detected, in the 100 Hz test this was no longer relevant and in fact the mobile phone camera and three volunteers detected it with the black background.

In her PhD thesis, Arexis [18] tried to identify the combinations of [frequency, duty cycle] that flicker is not perceivable by end-users (the sample size was in the order of 500 people).

To achieve that study four situations were defined as follows:

- Situation 1: 0% of end-users perceive flicker
- Situation 2: 5% of maximum end-users perceive flicker
- Situation 3: 20% of maximum end-users perceive flicker
- Situation 4: at least 50% of end-users perceive flicker

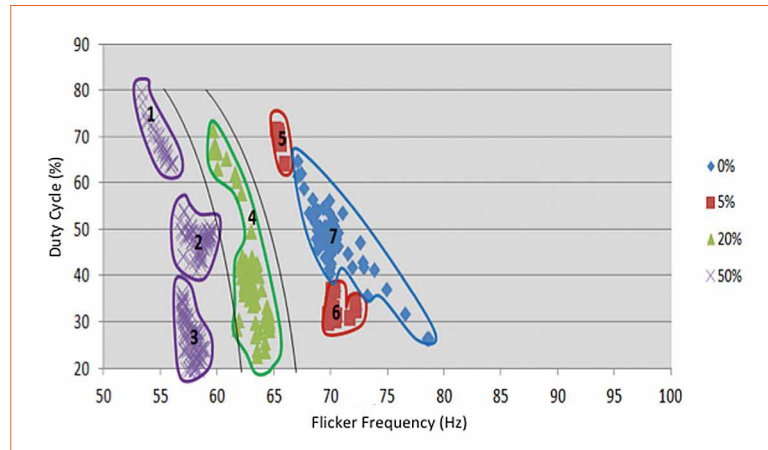

Figure 12: Pareto optimal solutions obtained by Arexis. The numbers indicate distinct “islands” in the [frequency, duty cycle] domain based on the 4 zones assumption (0%, 5%, 20%, 50%)

Using the obtained answers a Pareto optimality procedure was used in order to define the [frequency, duty cycle] areas that flicker is not perceivable. Pareto optimality is a state of allocation of resources in which it is impossible to make any one individual better off without making at least one individual worse off. To achieve this classification Arexis used the work of Villa et al [19] based on NSGA-II genetic algorithm. Figure 12 shows an example of results obtained by this method. As can be seen, the Pareto solutions are organized in 7 distinct islands: Island 7 corresponds to situation 1 (no flicker perception), Islands 5 and 6 to situation 2 (almost imperceptible flicker), Island 4 to the situation 3 (perceptible flicker) and Islands 1 and 3 correspond to situation 4 (noticeable flicker). This type of classification allows choosing power supply characteristics in such a way in order to avoid flicker and achieve energy savings.

Flicker and Standards

As has seen in the above paragraphs flicker is a very important issue that could impede SSL technology adoption from the general public. However, for the moment, no regulation of light flicker is really implemented in various world-region regulations. Flicker requirements could significantly improve commercial lamp evaluation for flicker, but in Energy Star® only apply to

dimable lamps within Energy Star requirements [20]. This is not an acceptable situation that scientists and policy makers tend to remediate.

In the absence of flicker metrics and waveforms, specifiers can pursue qualitative means for evaluating flicker. Specifiers should consider how the risk of flicker-related problems is heightened or reduced by a given light source, the type of space, its occupants, and the tasks being performed. In fact, flicker effects can be different following the executed task by the end-user. For static tasks or tasks with moderate eye motion limiting F at values lower than 0.5 should fine. In the case of more stringent tasks implying rapid movement of objects or visual fixation locations, F should be lower than 0.1. The case of confined environments has to be considered apart.

A first attempt to provide a generally accepted standard was to limit flicker passing through a maximum acceptable Flicker Index as a function of frequency within the 100 Hz to 800 Hz range following a linear relation:

$$\max(F) = 0.001 \cdot f \quad (7)$$

where f is the flicker frequency expressed in hertz. This criterion leads to $F < 1,2$ for USA at 120 Hz and $F < 1,0$ at 100 Hz for Europe. The rationale used by the US Environmental Protection Agency (EPA) to establish that limit appears to originate from experiments on high-quality conventional light

Figure 13:
Flicker Modulation depth as a function of flicker frequency. Flicker modulation is given for no effect level (green) and low risk level (yellow)

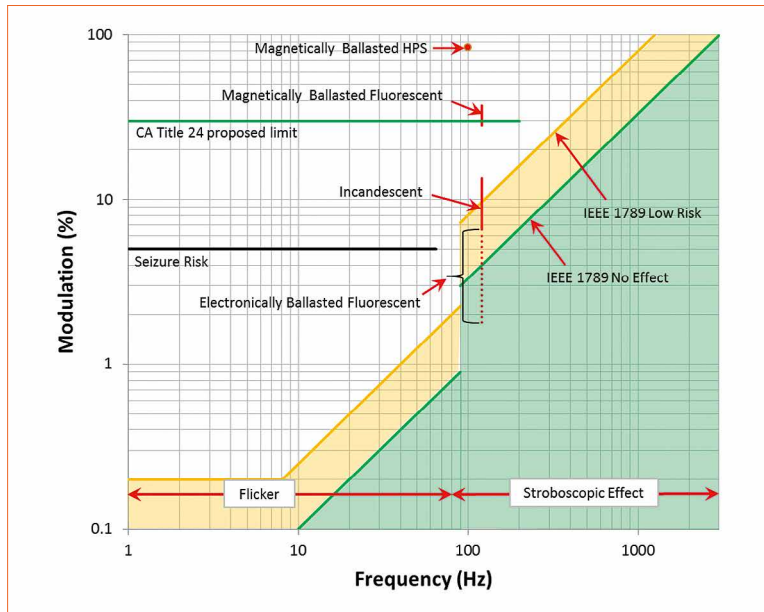

sources, including CFLs, performed by the US Department of Energy (DoE); in this work, the highest F value is 0.11 for magnetically ballasted CFLs. For the moment this requirement is still not included in the last version Energy Star requirements [20].

The Institute of Electrical and Electronics Engineers (IEEE) P1789 committee who has been working on light flicker for several years has recently published recommendations based Flicker Modulation metrics [21]. Figure 13 shows the proposed limits by Lehman and Wilkins [22]. It is more appropriate to refer to flicker based on f_d as the dominant flicker frequency (the term “dominant frequency” is used at two instances in IEEE 1789 recommended practice 2 [25] but not defined in the text). Furthermore, the IEEE recommendation fixes 90 Hz as cut-off frequency. This may be seen as a bad choice

because it leads to the rejection of “European flicker” at 100 Hz but not “US flicker” at 120 Hz. This recommendation leads to a Flicker Modulation up to 8.0% at 100 Hz and 9.6% at 120 Hz.

It should be underlined that IEEE 1789 is a recommendation and in any case can’t be seen as a flicker measurement standard. In fact, we don’t know how to handle complex waveforms with several Fourier components at different frequencies. IEEE 1789 suggests using spectral analysis based on Fourier transform but the “integrated criterion” is still an open area of research. IEEE 1789 suggests an algebraic sum but also mentions other integration methods (Minkowski norm for instance).

International Energy Agency 4E-SSL annex is now working also to establish flicker criteria inspired by the above IEEE recommendation.

The proposed criteria will be adapted to the “tier concept” proposed in the annex. These recommendations will be published sometime in 2016 in the next version of Performance Criteria. More information can be found at ssl.iea-4e.org web page.

More recently, Bullough and Marcus [23] conducted a study in which different temporal flicker waveforms at several frequencies, suggested that Flicker Index was a superior metric for characterizing stroboscopic effects than percent flicker. This is going to the opposite way of the IEEE standard.

In addition, NEMA in its position paper [24] asserts that current TLA standardization is hampered by lack of adequate TLA assessment metrics and that new flicker metrics and associated measurement methods for lighting are required. It is also underlined that this could add unnecessary cost to the electronics gears that may be not really justified.

Today, as per DoE advice [20], “...in the absence of flicker metrics LED systems should always be visually evaluated, ideally with flicker-sensitive clients. Waving a finger or pencil rapidly under the LED source, or spinning a flicker wheel, can expose the presence of flicker through the stroboscopic effect, even for those who are not naturally sensitive...” We should express the wish that a formal world acceptable standard will be adopted before “toxic”, low quality products and unscrupulous sellers poison the market. ■

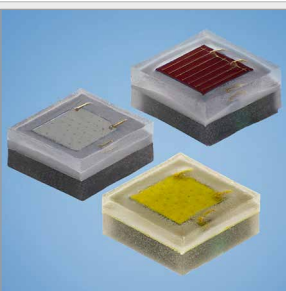

New Cree® XLamp® XQ-E High Intensity Color LEDs Offer Highest Candela Performance

XLamp® XQ-E High Intensity LEDs are the industry’s first family of color LEDs optimized to deliver the highest candela performance. The XQ-E High Intensity LED is the smallest building block for color LED designs, allowing lighting manufacturers to boost performance and reduce size for directional applications.

For additional information, please visit www.cree.com/xlamp/xqehi



References:

- [1] Berman S.M., D.S. Greenhouse, I.L. Bailey, R. Clear and T.W Raasch, Human electroretinogram responses to video displays, fluorescent lighting and other high frequency sources. *Optometry and Vision Science* 68(8), 645-662, 1990
- [2] Wilkins A.J., I.M. Nimmo-Smith, A. Slater and L. Bedocs, Fluorescent lighting, headaches and eye-strain, *Lighting Research and Technology*, 21(1), 11-18, 1989
- [3] Wilkins A.J., C. Clark, Modulation from fluorescent lamps, *Lighting Research and Technology* 22(2), 103-109, 1990
- [4] Wilkins A.J., P. Wilkinson, A tint to reduce eye-strain from fluorescent lighting, Preliminary observations, *Ophthalmic and Physiological Optics*, 11, 172-175, 1991
- [5] Hart WM Jr., Adler's physiology of the eye. Clinical application. Editors R.A. Moses RA, W.M. Hart, The C. V. Mosby Company St Louis, 1987
- [6] Jinno M., K. Morita, Y. Tomita Y. Toda, H. Motomura, *Journal of Light and visual environment* 32(2), 2008
- [7] Rea, M.S. (editor). IESNA Lighting Handbook: Reference and Application, 9th edition. New York: Illuminating Engineering Society, 2000
- [8] Poplawski, M., N.J. Miller, Exploring flicker in Solid-State Lighting: What you might find, and how to deal with it, Pacific Northwest National Laboratory, 2010 - <http://www.e3tnw.org/Documents/2011%20IES%20flicker%20paper%20poplawski-miller-FINAL.pdf>
- [9] Kitsinelis S., G. Zissis, L. Arexis, A study of flicker of commercial lamps, *Light & Engineering* 20(3) pp 25-33, 2012
- [10] Zissis G., S. Kitsinelis, L. Arexis, Etude comparative des effets stroboscopiques d'un échantillon de systèmes d'éclairage, Final Rapport, ANSES Convention 2010-CRD-22, 2011
- [11] US Department of Energy, Solid-State Lighting Technology Fact Sheet: Flicker, Building Technologies Office, PNNL-SA-94791, March 2013
- [12] Tähkämö L., M. Bazzana, P. Ravel, F. Grannec, Ch. Martinsons, G. Zissis Life cycle assessment of light-emitting diode downlight luminaire—a case study, *International Journal of Life Cycle Assessment* 18(1), DOI 10.1007/s11367-012-0542-4, 2013
- [13] Kitsinelis S., G. Zissis, Proceedings of 13th Int. Symposium on the Science and Technology of Lighting Systems, pp. 363-364, Troy NY (USA), 24-29 July 2012
- [14] Kukačka L., P. Dupuis, G. Zissis, M. Kolář, Retrofit LED Lamps - Photometric Flicker Analysis, Proceedings 50th IEEE IAS Annual Meeting, 18-22 October 2015, Dallas TX (USA).
- [15] Shady S., D.I.A. MacLeod, H.S. Fisher, Proceedings of the National Academy of Sciences (PNAS), 101(14): 5170-5173, 2004,
- [16] Bullough J. D., K. Sweater Hickcox, T. Klein, A. Lok, N. Narendran, Flicker Parameters for Reducing Stroboscopic Effects from Solid-state Lighting Systems, ASSIST recommends 11(1), May 2012
- [17] Arexis-Boisson L., S. Kitsinelis, G. Zissis, J. Salon, S. Martin, N. Ouahhabi, Visual Perception of LED Flickering Controlled in a Colored Environment, *Journal Light & Visual Environment* 37(4), pp. 183-188, DOI IEIJ130000504, 2014
- [18] Arexis, L. Etude et optimisation d'un système d'éclairage efficace énergétiquement et adapté aux besoins de ses utilisateurs (santé, sécurité et qualité de vie), Thèse de l'Université de Toulouse, 19 June 2014.
- [19] Villa C., Labayrade R., Multiobjective optimisation of lighting installations taking into account user preferences - a pilot study, *Lighting Research and Technology*, 45(2), pp. 176-196, DOI 10.1177/1477153511435629, 2013
- [20] ENERGY STAR® Program Requirements for Lamps (Light Bulbs) V2.0-Draft 3, 4 September 2015 - http://www.energystar.gov/sites/default/files/ENERGY%20STAR%20Lamps%20V1%201_Specification.pdf
- [21] IEEE, Standard 1789-2015 - IEEE Recommended Practices for Modulating Current in High-Brightness LEDs for Mitigating Health Risks to Viewers, June 2015
- [22] Lehman B., A.J. Wilkins, Designing to Mitigate the Effects of Flicker in LED Lighting: Reducing risks to health and safety, *IEEE Power Electronics Magazine*, pp. 18-26, DOI 10.1109/MPPEL.2014.2330442, September 2014
- [23] Bullough, J. D., D. Marcus, Influence of flicker characteristics on stroboscopic effects. *Lighting Research and Technology*, doi: 10.1177/1477153515599566, 2015.
- [24] NEMA, Temporal Light Artifacts (Flicker and Stroboscopic Effects), A NEMA Lighting Systems Division Position Paper, 15 June 2015 - <https://www.nema.org/news/Pages/NEMA-Lighting-Systems-Division-Publishes-Position-Paper-on-Temporal-Light-Artifacts.aspx>

The Role of Special Optics in Human Centric Lighting and Architecture

While Human Centric Lighting is relatively new and a topic of some debate, few can argue over the benefits of creating more natural lighting conditions in offices, retail spaces and other architectural settings. Anthony Ang, Optical Engineer, Suleyman Turgut, Director of Sales, and Mary Ann Giorgio, Marketing Communications Specialist at Luminitt LLC show how special or “tertiary” optics, such as diffuser and direction film, can play a crucial role in Human Centric Lighting or lighting that takes into account the emotional and biological needs of humans.

Advocates of Human Centric Lighting call attention to the benefits of a lumen-rich environment.

Health problems associated with poorly-planned lighting, such as loss of concentration, sleep disorders, fatigue, and irritability, are well documented, and these symptoms can be intensified for those with photophobia or a high sensitivity to light as well as for those with reduced visual acuity.

As standard lamps and fixtures continue to be replaced with energy-efficient LEDs, lighting designers and manufacturers face new challenges. The light emitted from a bare LED is highly directional compared to conventional sources but still too divergent for spot lighting applications. The primary optic lens reduces the divergence in all directions and restricts the light to a narrower cone angle of around 80°. An additional secondary optic such as a reflector or TIR optic is required to further collimate it to around 10° to allow the

light to illuminate objects greater than 1 meter away. A tertiary optic (i.e., diffuser, spread lens) is usually required as well to clean up any non-uniformity in the beam or modify the beam to the required shape and angle.

While color-changing LED bulbs that respond to human circadian rhythms, as well as advances in color temperature, illuminance and spread, are helping to improve SSL fixtures, even distribution is still difficult to achieve due to the concentrated and directional nature of LED light. LEDs also lack the intensity needed to effectively light a target plane more than half a meter away. Special optics such as diffusers and direction turning film incorporated during the design phase or out in the field can be an effective and economical way to control illuminance level, glare, uniform color temperature, beam direction and other factors that contribute to healthier or biophilic lighting.

The Role of Tertiary Optics in HCL

While secondary optics are essential to help collimate the beam, tertiary optics can take over where the capabilities of secondary optics end. For instance, HCL in a large retail store will be different from an office seeking to improve staff productivity through healthier lighting. Reflectors can have a counter-effect of glare when used in environments with shiny floors, and while TIR optics are effective collimation, they may not be as effective for downward recessed lighting where illumination needs to be diffused and cover a greater area. Such variances in applications is where tertiary optics such as Light Shaping Diffusers (LSDs) and prismatic optics such as Direction Turning Films (DTFs) can be helpful. Such beam shaping films can re-direct a light beam, enhance color uniformity, reduce glare and eliminate distracting LED hotspots. Tertiary optics can also aid designers faced with awkward spaces and less-than-ideal fixture placement.

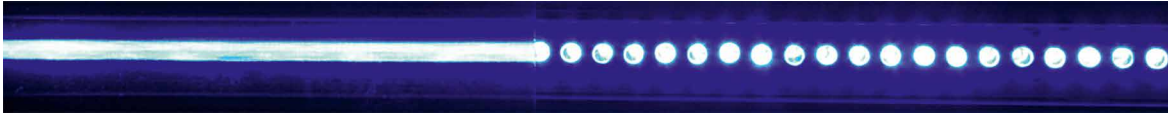

Figure 1:
Effects created by a
60° x 1° elliptical Light
Shaping Diffuser

Collimate then Expand

Light Shaping Diffusers use surface relief structures that are replicated from a holographically-recorded master. These pseudo random, non-periodic micro-structures manipulate light based on optical refraction by changing the direction of its energy. When applied to a lighting fixture or lamp, Light Shaping Diffusers allow the designer to shape a light beam to suit a particular need. LSDs can effectively improve the color and spatial uniformity, as well as reduce glare and multiple shadows. When incorporated into LED light strips, these diffusers can depixelate the LEDs, adjust the angle and improve uniformity of the secondary optics. This “collimate then expand” principle relies on a secondary optic to collect and collimate the light and a diffuser to expand the beam to the required beam angle.

Figure 1 shows an example of the effects created by 60° x 1° elliptical Light Shaping Diffuser on an LED strip light. The light is shaped by spreading the horizontal direction 60° and only 1° in the vertical direction and the result is the elimination of hotspots, Moiré, color diffraction, etc.

benefits of using DTF is that it allows for off-axis placement of an incoming beam, a feature that has many practical applications in human centric lighting.

Figure 2 demonstrates how a direction turning film allows for off-axis placement of an incoming beam, and when combined with a Light Shaping Diffuser can shape and homogenize the beam in addition the changing its direction.

Figure 3 shows the basic elements of a direction turning element and explains how it works. - A collimated light source enters from the left. The light is tilted 20° by the prismatic structure DTF then strikes the diffuser surface on the second side and spreads.

For example, we know that consumer behavior in retail stores is influenced by the shopper’s sense of well-being - if a shopper

feels comfortable, he or she may stay and shop longer - and poor lighting, particularly glare, can have a negative effect on mood. Because linear fixtures are frequently located in the center of shopping aisles, glare resulting from light reflecting on a shiny floor can be distracting. DTFs placed below the secondary optics can redirect the light from the floor to the merchandise, thus illuminating both sides of the aisle without affecting the people below the fixture. Creating an atmosphere that is more conducive to comfort can be accomplished with existing fixtures and without changes to secondary optics.

An example of how tertiary optics such as light Shaping Diffusers (LSDs) and prismatic optics such as Direction Turning Films (DTFs) can be used in large retail store environments where linear fixtures are frequently located in the center

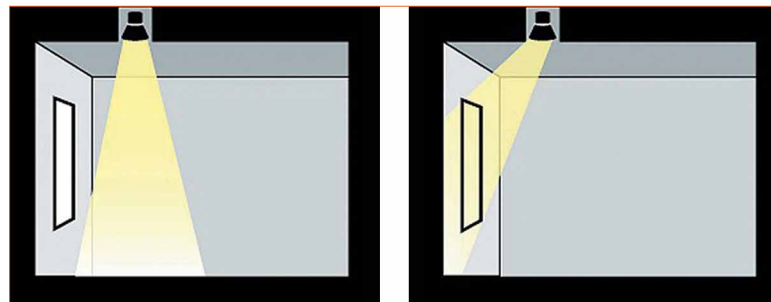

Figure 2:
Direction turning
films allow for off-
axis placement of an
incoming beam

The Role of Direction Turning Films in HCL

Direction Turning Film is another form of tertiary optics that gives designers greater control of beam angle. DTF is a non-symmetrical, linear micro-prismatic structure that imparts a 20° shift in the angle of a semi-collimated light source and is typically installed inside or above an LED-sourced luminaire or architectural feature. When combined with a Light Shaping Diffuser, the film allows designers to homogenize, redirect, and increase the beam angle of a light source. One of the major

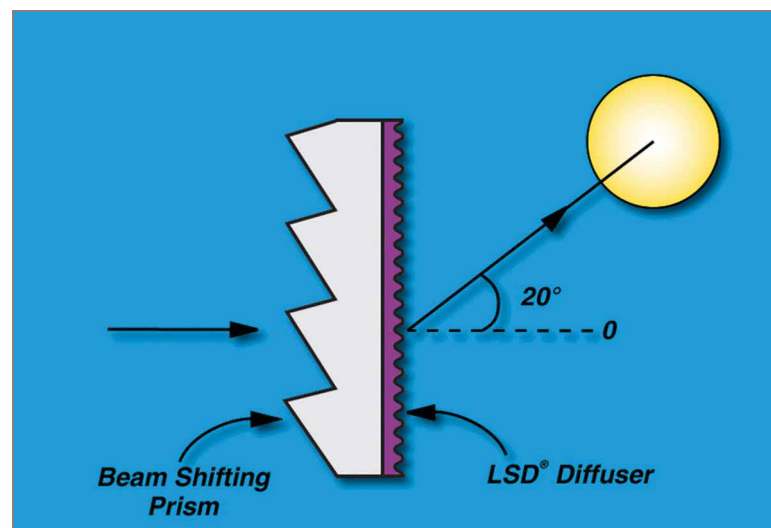

Figure 3:
Basic elements of a
direction turning
element and its
fundamental working
principle

Figure 4:
Application of light shaping diffusers and prismatic optics such as direction turning films in a large retail store environment



of shopping aisle is shown in figure 4. These films can re-direct a light beam toward the display aisles and away from a shiny floor, thus reducing glare and creating a more pleasing shopping experience.

In recessed down lighting, direction turning film can be applied to lights mounted in close proximity to a wall. A light beam that would normally point downward and reflect off a table, counter or other surface, can be redirected 20° to highlight or “wash” the wall, thus turning directional light into volumetric room lighting. The prismatic

structures of DTF can control directional light and provide better visual clarity, reduce glare and increase ground illumination in pathway/stairway lighting human centric conditions that can be especially helpful in hospitals and assisted living facilities. A diffuser placed on the opposite side of the film helps create a softer, more comfortable luminous environment as well as reduce shadows, glare and other factors that can lead to discomfort. DTFs can also be useful for in-grade lighting or recessed up-lights to direct the beam to the target wall or structure and

improve illumination and coverage. The DTF film has also been successfully implemented in pool lighting where the beam can be diverted to the bottom of the pool without angling the fixture.

Figure 5 shows an additional application example beyond common problems associated with interior lighting structures, DTF can also be used to redirect pool lighting. In addition to creating more pleasing and uniform coverage, the film helps prevent the blinding effects swimmers experience when swimming toward lights located beneath the surface.

Figure 5:
DTF can also be used to create more pleasing and uniform coverage. The image shows an example of redirecting pool lighting



Automotive Photonics Zone

Int'l Automotive Photonics Zone
www.optotaiwan.com

June 15-17, 2016 TWTC Nangang Exhibition Hall

Buyers Invitation for One-to-one Biz-match Meeting!

◆ Automotive Optics & Image System

- Car Camera Lens & CCD/CMOS Image Sensors
- Surveillance System & EDR (Event Data Recorder)
- Image Assistant System: IR Image, Lane Departure Warning System, Night Vision, Around View Monitoring, Side View System
- Parking System: Rear View Camera/RADAR, Auto Brake System
- LPR(License Plate Recognition)
- LiDAR System



◆ Automotive Display Panel AV Navigation System

- LCD/AMOLED Panel for Dashboard / Central Control Board / Navigation System
- Rear Mirror Display System: AR/VR
- HUD: Head-Up Display
- Rear Seat Infotainment Display System

◆ Internet of Vehicles & Sensor

- ADAS (Advanced Driver Assistance Systems)
- Cloud & Optical Communication
- V2V Communication
- Sensor: GPS, G-Sensor, Light Sensor, Temperature & Pressure Sensor, Gyroscope
- Traffic Flow Control System: Big Data, Cloud Storage
- Battery Diagnostic Service



◆ Automotive LED/Laser/IR/OLED Light Source \ PV

- Light Source—LED/OLED Package, Module, Light Engine
- Automotive Lamp: Head Lamp, Day Light Lamp, Fog Lamp, Turing Lamp, Flash Lamp
- Room Lamp, Trunk Room Lamp, Fender Marker Lamp, Decorative Light & Control System
- Automotive PV & Li-Battery Storage System



While DTFs have many practical applications in HCL, there are limitations designers need to take into account. The prismatic structure must face the LED, and DTFs are most effective when used on semi-collimated light over bare LEDs that produce large beam angles (more than 80°). The film can be placed directly on top of secondary optics but designers working with bare LEDs should allow some distance between the light and the film to avoid overheating.

Future Possibilities

While tertiary optics are primarily being used to enhance HCL in interior and architectural settings, DTFs are also being incorporated into avionic displays to provide optimal viewing angles for pilots and co-pilots. Other possibilities include sunlight harvesting for energy-efficient buildings where direction turning film can be applied to windows to re-direct sunlight toward the ceiling where it can be scattered downward to illuminate larger areas of the space.

The possibilities of these tertiary optics are limited only by the imagination and ingenuity of engineers, designers and the LED industry as a whole. However, the ability to shape light and send it where it is needed most without changes to the fixture allows designers to incorporate human centric lighting principles to even the most impractical rooms and spaces. ■

LED

Within the exhibition

**E·X·P·O
ELECTRONICA**

ufi
Approved
Event

Specialised exposition

LED components, materials,
technologies, equipment,
and ready solutions

Organisers:



+7 (812) 380 6003/07/00
electron@primexpo.ru

0+

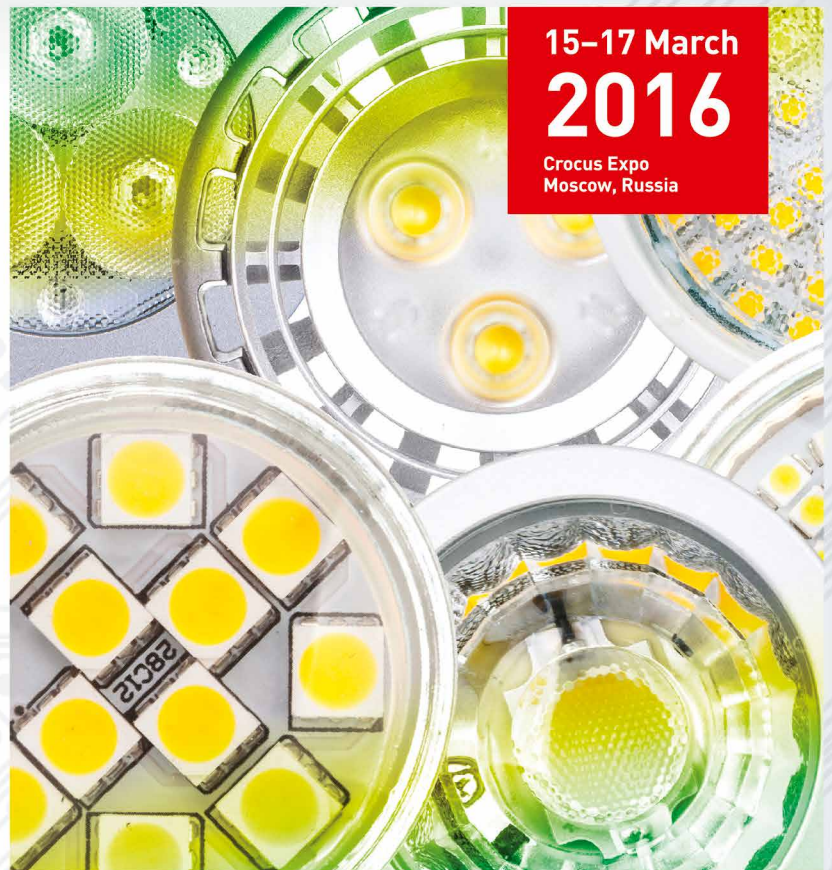

15-17 March

2016

Crocus Expo
Moscow, Russia

Book your stand:
expoelectonica.ru

NEW LIGHT OF ELECTRONICS

LED & Display Industry Platinum

The 14th International

LED & OLED EXPO 2016

2016. 6. 22(Wed) ~26(Sat) / KINTEX, KOREA

Concurrent Exhibition : Int'l LASER EXPO 2016
The 6th LED Industry Forum

World's top B to B trade show for the LED & OLED industry
Now open for participating company!



LED



OLED



Display



LASER



Forum

Why should Exhibitors Choose LED & OLED EXPO?

- World's first B to B trade show for the LED industry (in 2003)
- Certified by UFI(Union des Foires Internationales)
- Certified by Ministry of Trade, Industry & Energy.
- Provide customized top-tier business market place & network
- Government Award for high technology development of exhibitors.
- Int'l LASER EXPO & LED Industry Forum as concurrent event.



Int'l LED &
OLED EXPO Secretariat

Tel : 82-2-783-7979

E-mail : led@exponu.com

Website : www.ledexpo.com

Fax : 82-2-783-7292

oled@exponu.com

www.oledexpo.com

<http://twitter.com/ledexpo>

<http://www.facebook.com/LEDEXPO>

<http://www.ledexpo.net/>

Please find
more information
from QR codes



LEDEXPO



OLEDEXPO



LED professional Review (LpR) - Annual Subscriptions

LpR Digital Magazine

- 6 issues
- pdf download
- high resolution pictures and graphs
- printable
- commercial use
- access to all previous issues
- Euro 78.80

LpR Printed Magazine

- 6 issues
- Euro 158.40

<http://www.led-professional.com/subscription>

Cover-page

Artwork: Thomas Klobassa,
©LED professional 2015

Main Image: Arno Grabher-Meyer,
LED professional

Product: Zumtobel Masterpiece
Vortexx from Zaha Hadid

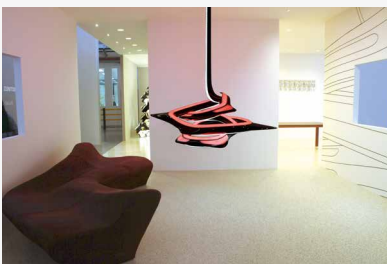

The Masterpiece Vortexx by Zaha Hadid, professor of Architecture and Design, was one of the eye catching exhibits showcased at the Zumtobel IYL event in April, 2015

Next LpR

TRENDS & INNOVATIONS Issue 54 - March/April 2016

TECHNOLOGIES

How Network Connected Lighting Is Driving Energy Efficiency, Productivity and Smart Buildings

Today, information technology (IT) and lighting are separate worlds. It is necessary to create a bridge between these worlds, not only from a technical standpoint but also from the perspective of understanding what is important to each industry. The article discusses how LEDs and PoE may pave the way. ■

Safety Concept for LED Street Lighting

Street and building lighting has profited greatly from the advantages of LED technology. While modern LED lampposts have dielectric strengths of up to 8 kV, surge currents and voltages occurring in the grid can be significantly higher. A comprehensive power surge protection concept to prevent blackouts during power surges and to protect investments in LED lighting will be presented and discussed. ■

RESEARCH

“Best Papers” at LpS 2015: Thin-Film Light Management System for Intelligent Large-Area LED Luminaires

The recent advances in Solid State Lighting have triggered the development of smart lighting solutions. However, the point-like nature of the LEDs imposes the use of light scattering sheets or short-pitch LED arrays to achieve acceptable spatial luminance uniformity. As a new approach, an innovative thin form-factor light management (LM) system comprising a highly engineered combination of thin-film diffractive nano and refractive micro-optical elements is presented. ■

APPLICATION

Schools Install LEDs to Assist in Sustainability Efforts

The US education sector continues to adopt LED lighting at increasing rates. High quality LED lighting emits a full - and sometimes tunable - light spectrum. It provides superior color rendering to enhance visual acuity within the classroom. It is said to improve behavior, reducing stress, anxiety, and reducing absenteeism. The article discusses expectations and experiences, and it gives technical background information. ■

SPECIAL

The Value of Dark Skies - About Environmentally Friendly Lighting

For many years no one worried about light pollution: on the contrary, the brighter the better. Then it became evident that darkness also has its value. The article presents and explains in detail, the latest findings and suggestions published in the “New IDA LED Lighting Practical Guide” and “New IDA Standards on Blue Light at Night”. How to illuminate public spaces while avoiding excess light pollution is also discussed. ■

subject to change

Imprint

LED professional Review (LpR), ISSN 1993-890X

Publishing Company

Luger Research e.U.

Institute for Innovation & Technology
Moosmahnstrasse 30
A 6850 Dornbirn, Austria / Europe
phone +43 5572 39 44 89
fax +43 5572 20 60 70
info(at)lugerresearch.com
www.lugerresearch.com

Publisher

Siegfried Luger +43 699 11 33 55 70
s.luger(at)led-professional.com

Editor-in-Chief

Arno Grabher-Meyer +43 699 11 33 55 18
a.g-m(at)led-professional.com

Int. Account Manager

Theresa Koenig +43 699 11 33 55 20
theresa.koenig(at)led-professional.com

Marketing & Sales Manager

Katharina Fink +43 699 11 33 43 43
katharina.fink(at)led-professional.com

Your Local Contacts

China, Hong-Kong

Iris Yuen +86 1380 27 01 367
irisyuen88(at)gmail.com

Germany

Armin Wezel +49 30 526 891 92
armin(at)eurokom-media.de

India

Sudhanshu Shekhar +91 22 4127 9682
ledpro(at)binarysemantics.com

Japan

Eiji Yoshikawa +81 3 6751 0090
scala(at)s3.dion.ne.jp

South Korea

Jung Won Suh +82 2 78 58 222
sinsegi-2(at)sinsegi-media.info

Switzerland

Monika B. Ailinger +41 41 850 44 24
m.ailinger(at)marcomedia.ch

Taiwan

Leon Chen +886 2 256 81 786-10
leon(at)jkmedia.com.tw

United Kingdom, France & Benelux

Zena Coupé +44 1923 85 25 37
zena(at)expomedia.biz

US East

Karen C Smith-Kernc +1 717 397 7100
KarenKCS(at)aol.com

US West & Canada

Alan A. Kernc +1 717 397 7100
AlanKCS(at)aol.com

Copyrights - Luger Research e.U.

The editors make every reasonable effort to verify the information published, but Luger Research e.U. assumes no responsibility for the validity of any manufacturers, non profit organisations or individuals claims or statements.

Luger Research e.U. does not assume and hereby disclaims any liability to any person for any loss or damage caused by errors or omissions in the material contained herein, regardless of whether such errors result from negligence, accident or any other cause whatsoever. You may not copy, reproduce, republish, download, post, broadcast, transmit, make available to the public, or otherwise use LED professional Review (LpR) content without prior written consent from Luger Research e.U. - Institute for Innovation & Technology, Austria. ■



! GET YOUR FREE E-MAGAZINE
www.led-professional.com/free



Trends & Technologies for Future Lighting Solutions.

LEDs • OLEDs • Light Engines • Lighting Modules • Optics • Drivers • Thermal Management • Lamps • Fixtures • Production & Measurement Equipment
 Project Reports • Patent Reports • Research Reports • Event Reports

LED
 professional

MORE THAN
25,500
 READERS

Visit us at
light+building
 Hall 4.1, Booth No. B11

www.led-professional.com

powered by Luger Research e.U.

Submit your article. Please contact Arno Grabher-Meyer, Editor in Chief, at a.g-m@led-professional.com

Small is Big

4,5
mm



For Manual and
Automated Wiring Systems
2060

5,6
mm



For Direct
Power System Feed-In
2061

2,7
mm



For the
Smallest Sizes
2059

The Range of SMD Terminal Blocks

www.wago.com/smd

**WE
INNOVATE!**



WAGO[®]