



TTB: Dr. J. Norman Bardsley

Research: Roadway Lighting & Perovskite Nanocrystals

Technologies: Thermal Management & Smart Lighting

Applications: SSL Horticulture & Animal Farming

**FUTURE**  
Lighting Solutions  
www.FutureLightingSolutions.com  
**LIGHTFAIR International 2017**  
May 9<sup>th</sup> – 11<sup>th</sup> 2017  
Booth #: 3515  
Pennsylvania Convention Center





## Lumileds Matrix Platform built-to-spec You dream it—we build it.

With the revolutionary Lumileds Matrix Platform, you get market-leading LUXEON LEDs configured exactly how you want them for use in your most exacting luminaire designs. Available fully assembled on flexible or rigid substrates and integrated with optics, connectors, wiring, driver on board and electronics—Lumileds will work with you to ensure the configuration you select is optimized for your specific form factor. For virtually limitless options, reduced manufacturing waste and faster time to market, look no further than Lumileds Matrix Platform built-to-spec modules and integrated solutions.

For more information, visit [lumileds.com/products/matrix-platform](http://lumileds.com/products/matrix-platform) or contact your Lumileds sales representative today.

### Oberon Inline Kitting

This proprietary Lumileds technology is the industry's only pick-and-place system that:

- Uses algorithms to select the optimal mix of LEDs
- Chooses from a large bank of LEDs based on tested color, flux and  $V_f$  performance
- Enables the narrowest distributions—compared to standard level 1.5 kitting and binning methods
- Matches emitter-to-emitter output to ensure predictable performance



LUMILEDS ILLUMINATION LEDs

LUXEON HIGH POWER LEDs • LUXEON MID POWER LEDs • LUXEON CoB LEDs • LUXEON COLOR LEDs • LUXEON UV LEDs • **MATRIX PLATFORM**



**FULHAM**  
**HOTSPOTLED™**

# Emergency Solutions

Reliable, intelligent, integrated.  
Fulham takes LED emergency lighting to the next level.



**FULHAM**  
**HOTSPOTLED**

## HotSpot Plus: The All-in-One Driver Solution, Now Available for Europe

The first fully integrated programmable LED driver, emergency LED driver, and replaceable backup battery. A revolutionary design that reduces costs, simplifies installation, and brings emergency capability to smaller luminaires. Range of form factors, and new model for Europe now available.



**FULHAM**  
**HOTSPOTLED**

## HotSpot Constant Power: Programmable Output for Reliable Emergency Power

An advanced modular solution that ensures proper illumination in emergency situations. Programmable, self-diagnostic, easy to install, and featuring a highly efficient design to meet California Energy Commission Title 20 requirements.

Contact us today to learn more about Fulham's innovative LED solutions

North America  
order@fulham.com  
+1 323 599 5000

Europe  
sales.eu@fulham.com  
+31 72 572 3000

**FULHAM**  
*Lighting... Global. Intelligent. Sustainable.*

[www.fulham.com](http://www.fulham.com)

Visit us at Lightfair: May 9-11, **Booth 3101**



# Multi-Connectivity

It's a well-known fact that connectivity is one of the major aspects of Solid-State lighting systems. Nowadays, a stand-alone is not enough because of the various, new functionalities that are continuously added to systems based on information distributed through the Internet gathered from sensors outside of the lighting world in buildings or from data stored in a cloud. Lighting system manufacturers face difficulties when asking clients, experts and users what kind of interfaces should be integrated and provided in their products. In order to understand what they are faced with let's have a look at some of the key interfaces:

**DALI** is described as a protocol for communications and the control of lighting equipment. The controller can monitor and control each DALI gear by means of a bi-directional data exchange. The DALI protocol permits devices to be individually addressed and it also allows multiple devices to be addressed simultaneously via multicast and broadcast messages. DALI 2 expands from Control Gears to support Control Devices (push buttons, presence detectors and light sensors).

**ZigBee** is a wireless technology developed as an open global standard to address the unique needs of low-cost, low-power wireless M2M networks. The ZigBee standard operates on the IEEE 802.15.4 physical radio specification and operates in unlicensed bands including 2.4 GHz, 900 MHz and 868 MHz. The specification is a packet-based radio protocol intended for low-cost, battery-operated devices. The protocol allows devices to communicate in a variety of network topologies and can have battery life lasting several years.

**Smart Mesh** specification is defined by the Bluetooth Special Interest Group (SIG) to enable an interoperable mesh networking solution on the Bluetooth Smart (BLE) wireless technology. The Smart Mesh overcomes range limitation by creating a mesh network and its specification is defined to support Bluetooth Smart specification versions 4.0 and beyond.

All three of these lighting communication interfaces are designed for dedicated purposes and have strengths and weaknesses, depending on the application. New systems should cover all the interfaces at once because it can't be predicted where the system will be installed and what the user will need to control and connect with the lighting system.

Multi-connectivity seems to be a major trend for new lighting solutions. It eliminates the need for gateways and transfers the complexity to the luminaires or drivers as part of the lighting system. This, of course, will increase the complexity of the hardware and software of future lighting systems, but the multi-faceted lighting market, with all its different standards, interfaces and applications needs, cannot be limited to a One-Only approach. Multi-connectivity is a major challenge for developments, products, testing and maintenance but I believe it to be the winning strategy and trend. For more information on this subject, see the article by Dr. Kyeongik Min of Samsung Electronics. It's just one of many thought-provoking articles in this edition of the LpR.

Have a good read.  
Yours Sincerely,

Siegfried Luger  
Publisher, LED professional  
Event Director, LpS & TiL



# 30% MORE LIGHT



Outperforms all four-chip solutions by creating 30% more light

Plessey's PLW7070 single chip 12V and 3V LEDs provide a 30% increase in light output when using any standard secondary optics.

#### In addition, Plessey's PLW7070:

- Eliminates the shadowing effects present when using a multiple-die approach
- Provides greater reliability thanks to advanced thermal management
- Delivers the ability to maintain luminous flux over the widest possible temperature range
- Operates at input currents from 350mA to 3A (1W to 15W power levels) and 3V to 24V

#### Applications

- Spotlights
- Floodlights
- Streetlights
- High bays
- Portables

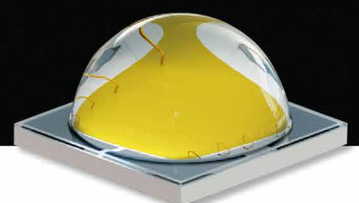

#### Contact Plessey:

+44 1752 693000 | [sales@plesseysemi.com](mailto:sales@plesseysemi.com)

Subscribe to the latest Plessey news:

[www.plesseysemi.com/register/lpr\\_01](http://www.plesseysemi.com/register/lpr_01)



The technology of light



COMMENTARY

08 From Component to System  
by Andreas Weisl, Seoul Semiconductor

TECH-TALKS BREGENZ

32 Tech-Talks BREGENZ - Norman Bardsley, President of Bardsley Consulting  
compiled by Arno Grabher-Meyer, LED professional

RESEARCH

40 Roadway Lighting Optics for Environment Adaptive Spatial Light Distribution  
by Viktor Zsellér & Dr. Krisztián Samu, Budapest Univ. of Technology & Economics

46 Lead Halide Perovskite Nanocrystals - A New Promise for Light Emitting Devices  
by Mirko Prato & Francesco Di Stasio, Istituto Italiano di Tecnologia

TECHNOLOGIES

54 A Standardized Open Platform Is Key to the Future of Smart Lighting System Design  
by Dr. Kyeongik Min, Samsung Electronics

60 Looking for the Best Thermal Solution for CSP Module Designs  
by Dr. Giles Humpston, Cambridge Nanotherm

APPLICATIONS

64 Bio-Effective Lighting for Humans, Livestock and Plants  
by Volker Neu, Vossloh-Schwabe Lighting Solutions

68 SSL Growth Strategies and USDA Corn Breeding Objectives  
by Brandon Newkirk, LumiGrow

REGULARS

04 EDITORIAL  
08 COMMENTARY  
10 PRODUCT NEWS  
25 RESEARCH NEWS  
28 REGULATION NEWS  
30 CIE RESEARCH

74 ABOUT | IMPRINT

HIGHLIGHT

54 A Standardized Open Platform Is Key to the Future of Smart Lighting System Design  
Dr. Kyeongik Min, Samsung Electronics

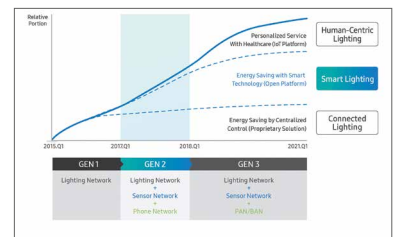

ADVERTISING INDEX

FUTURE LIGHTING SOLUTIONS	1	EDISON	21	FLS-PHILIPS	51
LUMILEDS	2	EPISTAR	23	CREE	52
FULHAM	3	DOW CORNING	24	INSTRUMENT SYSTEMS	57
PLESSEY	5	LEDFRIEND	26	INTERLUMI PANAMA 2016	59
FUTURE LIGHTING SOLUTIONS	7	GRE ALPHA ELECTRONICS	26	SEOUL SEMICONDUCTOR	63
MOSO	9	CREE	27	LIGHT FAIR INTERNATIONAL	67
WAGO	11	OSRAM	29	GUANGZHOU INT.LIGHTING EXHIBITION	69
IMOS GUBELA	13	TRENDS IN LIGHTING	35	LED LIGHTING TAIWAN	71
RECOM	15	LED PROFESSIONAL SYMPOSIUM	39	LED EXPO THAILAND	73
ELECTRO TERMINAL	17	FUTURE LIGHTING SOLUTIONS	45	LED PROFESSIONAL REVIEW	75
EVERFINE	19	FLS-NICHIA	49	ACEVEL	76



*Making LED Lighting Solutions Simple™*



# We Accelerate Time to Revenue by Providing

- ▶ The Most Comprehensive System-Level Product Portfolio
- ▶ Solid-State Lighting Expertise
- ▶ Design Support Services
- ▶ Global Supply Chain and Business Solutions

**LIGHTFAIR International 2017**  
May 9<sup>th</sup> – 11<sup>th</sup>, 2017  
Booth #: 3515  
Pennsylvania Convention Center

 **FUTURE**  
Lighting Solutions

[www.FutureLightingSolutions.com](http://www.FutureLightingSolutions.com)





### Andreas Weisl

Andreas Weisl (38), former Vice President Europe of Korean LED manufacturer Seoul Semiconductor (SSC), has taken on the position of CEO at Seoul Semiconductor Europe GmbH based Munich, Germany, with effect from November 11, 2016. In his role as General Manager for Central and Northern Europe since 2010, and as Vice President Europe since 2014, Mr. Weisl is part of the SSC executive and is responsible for business developments in Europe. Mr Weisl looks back on more than eleven years of experience in the area of LEDs before coming to SSC in 2010. Previously he served as a manager, among other roles, at Osram Opto Semiconductors.

## FROM COMPONENT TO SYSTEM

The history of Light-Emitting Diodes (LED) is quite short compared with some other electronic device industries. However, it has changed and revolutionized the entire world of light within a very short period of time.

LEDs didn't start out as lighting applications but rather the colored indicator lights used for consumer electronics and automotive interiors. Before the invention of the so-called InGan based semiconductor in the 1990's it wasn't possible to develop LEDs creating blue light, which is the basis for white light. At the beginning, efficacy was so low that there were serious doubts about whether it would be possible to meet future lighting requirements either in general lighting or automotive exterior lighting.

The similarities to the traditional semiconductor business, also in terms of development, production and sales structures, and taking Moore's Law into consideration as an indicator for the semiconductor industry, the question of how fast LED components will develop every decade was raised. According to the Haitz Law, the LED counterpart to Moore's Law, the cost per lumen falls by a factor of 10 every decade with the amount of light generated, increasing by a factor of 20. Haitz's Law predicts an exceptional improvement in semiconductors used in LED technology. This was advantageous for semiconductor manufacturers because it meant they could rely on their long-time experience and competence in the industry that is now benefiting from booming LED trends.

As a consequence, it wasn't long before the LED could be used for low efficacy illumination. And a few years later LEDs were brought to the market with highly developed efficacy, luminosity and light quality. Today, LEDs can easily compete with or even outperform conventional light sources. At the same time new form factors and extended life times compared to conventional lighting technologies,

has been achieved. This has facilitated completely new lighting applications.

New technologies such as AC solutions and interconnectivity are becoming increasingly important - enabling completely new application and form factors in regards to developments in the areas of Smart Lighting, Human Centric Lighting, LiFi, IoT and more complex, smarter city concepts.

Many semiconductor manufacturers have identified potential synergies and entered the LED market in order to combine the knowledge of their previous business approaches with new business chances due to their competency in traditional semiconductor manufacturing and also in terms of the digitalisation of light.

A future trend will be to fulfil the requirements of new solutions while making end device manufacturers' lives easier. Power of innovation and a good time-to-market approach are today's success factors. Companies like Seoul Semiconductor have found that offering module solutions, especially customized solutions, based on technologies enables customers to realize their results faster than by just using LED components. Limited resources in customer companies need intelligent, reliable and easy to handle solutions in order to meet their requirements and help their business grow. Pure LED component manufacturers often do not have the capability to follow this trend. Only solution providers can help customers to find any solution they need.

By focussing on module solutions in order to meet global market and customer requirements, solution providers are helping their customers to stay ahead of the competition and they are very often first to market. However, this should be the only step forward in regards to forward integration so they don't end up competing with their own customers. From a component to a system – the ideal solution. ■

A.W.



**MOSO**<sup>®</sup>

# Programmable LED Drivers Enlighten Fixture Design



## Flexible & Reliable

TUV CE CB SAA BIS EN

### FEATURES:

- \* Programmable Constant Current Output
- \* Current Adjustable for Full-power
- \* 0~10V / PWM / Dali / TIME Dimmable
- \* 93% High Efficiency
- \* Universal Input Voltage 90~305Vac / 249~528Vac
- \* Lightning Protection: 5KV L-N, 10KV L/N-GND
- \* Compliant to DLC ERP ENEC



🏠 : [www.mosopower.com](http://www.mosopower.com) ✉ : [yoyo@mosopower.com](mailto:yoyo@mosopower.com) ☎ : +86 755 27657708

## Looking for Distributorship

## Seoul Semiconductor Starts Mass Production of Patented Filament LEDs

Seoul Semiconductor, a world leader in LED-technology, announced the immediate start of the mass production of its LED Chip-On-Board Package for use in LED filament bulbs, a market currently estimated to be \$1.3 billion globally.



**SSC decided that the time has come for filament LEDs and started mass production of their patented 38 mm and 50 mm filament LEDs**

Seoul Semiconductor's CTO, Mr. Ki-Bum Nam, said, "Based on its strong patents, Seoul Semiconductor will continue to increase its market share in the filament LED bulb market, which is a blue ocean market estimated at \$1.3 billion." He added: "We will widely promote the superiority of Seoul Semiconductor's LED technology with its filament LEDs."

Seoul Semiconductor's filament LEDs can realize high-quality light close to natural light through differentiated Chip-On-Board (COB) packaging technology and can produce stunning emotional lighting with omnidirectional emission technology, combining a small footprint with a wide beam angle. The Color Rendering Index (CRI) is 80 or better and different LEDs with a flux between 105 and 210 lumens are available. All of them feature a Correlated Color Temperature (CCT) of 2,700 K. Therefore, they are used to create a classical atmosphere through high-quality light in many spaces, like cafes and hotels or even bedrooms and living rooms, making them an alternative to incandescent light bulbs that were phased out in 2014.

Development of this technology at Seoul Semiconductor started in the early 2000s, even before there was a market for filament-LEDs, but production was held off until the market was ready for them. This decision demonstrates the company's clear, long-term strategy and vision. Seoul Semiconductor

now holds hundreds of patents for filament LEDs, covering chip manufacturing, COB-packaging, module and bulb manufacturing processes. These are all core technologies for manufacturing filament LED products and this portfolio leads to a strong IP protection of customers using Seoul Semiconductor's filament LEDs.

An official at Seoul Semiconductor stated: "We are readying legal actions, as many of the LED bulbs released in the market have infringed on our proprietary technologies."

The application of filament LEDs in the light bulb market has started and they can not only be applied to globe bulbs in their various forms, but also to candle lamps in special shapes. These diverse applications are supported by two different lengths of the LEDs, 38 mm and 50 mm. ■

## Samsung Introduces Second Generation Chip-on-Board LEDs

Samsung Electronics Co., Ltd., a world leader in advanced component solutions, announced its second generation of D-series chip-on-board (COB) LED packages. The second generation features the industry's highest light efficacy in COB lineups and is suitable for directional lighting applications such as multifaceted reflector (MR) bulbs, parabolic aluminized reflector (PAR) lamps, spotlights, downlights and high bay lights.



**Samsung's second generation Chip-on-Board LED Packages offer improved efficacy and lower thermal resistance**

This new D-series Generation 2 offers efficacy at 160 lm/W (5000 K CCT, 80 CRI, 85°C) – a significant improvement from the Gen 1 efficacy level of 150 lm/W. The Gen 2 additions greatly enrich Samsung's COB lineup by providing more extensive lighting source options for spot lighting and most

other directional lighting. The D-series Gen 2 also features about 50 percent lower thermal resistance than the first generation.

In addition, all 11 different wattage offerings in the D-series Gen 2 deliver high reliability and performance levels that meet DLC Premium standards (technical requirements for LED lighting solutions suggested by DesignLights Consortium™). DLC standards are recognized in North America as a preferred means of evaluating LED lighting products in terms of performance and quality.

The D-series Gen 2 is available for a wide range of color rendering index levels from CRI 70+ to 90+, and for "Vivid" lighting, in providing color spectrums that have been optimized for retail markets. This satisfies the need of many lighting designers to have richer, more vibrant, colors. ■

## New Cree C1010 LEDs for High Definition Indoor Video Screens

Cree, Inc. announces the C1010 LED, a breakthrough three-in-one RGB Surface Mount Device (SMD) LED that enables display manufacturers to create state-of-the-art video displays that are sharper and more dynamic than previously possible. Featuring the best far field pattern matching and the lowest power consumption in its class, the new LED delivers 40 percent better contrast ratio and a longer lifetime than competing LEDs. The C1010 is the only high-density display LED with zero cross talk between pixels, eliminating the need for louvers that add cost and weight to displays.



**Cree claims that their new C1010 LEDs deliver industry's best contrast and reliability for HD indoor video screens**

"Cree is again leading with game-changing innovation that will enable new high definition LED video screens," said Dave Emerson, vice president and general manager for



# Small is Big

For Manual and  
Automated Wiring Systems  
**2060**

For Direct  
Power System Feed-In  
**2061**

For the  
Smallest Sizes  
**2059**



**297** For Vertical  
Wiring

**2065** Reduced to  
the Essentials

The Range of  
SMD Terminal Blocks

[www.wago.com/smd](http://www.wago.com/smd)

**WE  
INNOVATE!**

**WAGO**

Cree LEDs. “The robust C1010 opens up new applications for high density displays and continues Cree’s record of technology breakthroughs for display LEDs, including the first tilted-angle radiation pattern LEDs and the first waterproof SMD LEDs.”

The C1010 has been proven to deliver more than double the lifetime of competing LEDs under accelerated high temperature and high humidity testing conditions. The C1010 LED delivers up to 140 mcd at 5 mA in a compact ultra-black 1.0x1.0 mm package to maximize contrast under all viewing conditions.

“Cree’s new C1010 LED will revolutionize the high density LED display market, enabling us to deliver the maximum visual impact to our customers,” said Aaron Wu, AOTO Electronics Deputy General Manager. “The C1010 creates a noticeably higher quality image than any other small pitch LEDs that we have evaluated and is backed by the best reliability data in the industry.” ■

## ROHM Introduces the World’s Smallest Reflector-Type High Brightness 3-Color LED

ROHM has recently announced the availability of an ultra-compact reflector-type LED optimized for consumer devices such as matrix light sources for gaming and wearable’s that demand increased miniaturization.



**ROHM’s compact, high ESD resistance design of the MSL0402RGBU LED provides greater design flexibility in matrix applications**

The MSL0402RGBU reflector-type 3-color LED leverages miniaturization technology cultivated over many years to achieve the smallest size in the industry (1.8x1.6 mm). This enables high-density mounting and provides excellent color mixing characteristics, ensuring support for high-resolution LED matrices.

In order to turn on matrix light sources it is necessary to take measures against ESD. Unlike conventional solutions that utilize a Zener diode, the MSL0402RGBU adopts an element with high ESD resistance. This makes it possible for superior ESD protection without a Zener diode and prevents light emission of unnecessary blocks in matrix circuits, resulting in clearer display.

As applications become smaller and more sophisticated the need for greater expressiveness grows, along with increased miniaturization and long-term reliability. Up until now, ROHM has offered ultra-compact molded type LEDs (PICOLED®), high brightness reflector types (MSL series), and compact high brightness 3-color LEDs with excellent color mixing, but to meet market demands ROHM has developed the industry’s smallest high brightness reflector-type RGB LEDs (MSL0402RGBU).

### Applications:

- Matrix light sources for gaming and entertainment
- Display light sources for industrial and consumer equipment

### Key Features:

Reflector-type high brightness RGB LED delivers greater color representation in the smallest form factor on the market.

Until now, 3.5 x 2.8 mm LEDs are typically used in dot matrices, resulting in a coarse display, which can be problematic when higher resolution is demanded. In response, ROHM utilizes miniaturization technology to reduce the mounting area by 70% over ROHM’s conventional LEDs. This makes it possible to construct high brightness, ultra-high resolution matrix light sources that contribute to improved performance and display capability in many applications.

### Anti-sulfuration performance:

The combination of silver plated frames and silicon resins used in conventional LEDs will typically result in a drop in brightness after 1 year due to 30% sulfuration caused by sulfur components in the air originating from tobacco smoke and exhaust gases, presenting problems for long-term reliability. In response, the MSL0402RGBU utilizes a gold plated substrate that prevents sulfuration even when silicon resin packages are used. This minimizes brightness degradations and contributes to greater long-term application reliability.

### High ESD resistance eliminates the need for a Zener diode:

Normally, Zener diodes are used as a countermeasure to static electricity in LEDs. However, in matrix circuits this can cause current to flow to other LEDs, resulting in unwanted light emission. In contrast, the MSL0402RGBU employs a high ESD resistance element that eliminates the need for a Zener diode, ensuring superior display performance in matrix circuits. ■

## Lumileds Highly Efficient Multi-die Emitter for Robust Outdoor Fixtures

Lumileds has introduced the LUXEON MX, a multi-die emitter that delivers industry leading efficiency and flux for outdoor fixtures and high bay lighting applications. Lighting fixtures benefit from the emitter’s 1,200 lumen, 150 lm/W efficacy, at 85°C (4000-6500 K and 70 CRI) which enables a system efficiency of 120 lm/W when driven at 700 mA.

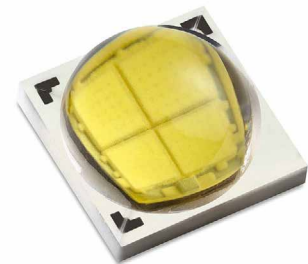

**The LUXEON MX is the only emitter in its class (4000K-6500K and 70 CRI) to deliver 1,200 lumens at 150 lm/W in a 12-volt configuration**

Seth Danielson, product manager for the LUXEON MX explains: “This is double the flux of comparable emitters in 120 lm/W systems. We’ve achieved this performance leap by optimizing the LED for improved efficiency at higher drive currents up to 1.5 A with the 12 V device.”

With these developments, Lumileds has maximized emitter efficiency and lifetime. Most impressively, the LUXEON MX makes it possible for luminaire makers to meet the efficiency and quality requirements of the DesignLights Consortium® (DLC) Premium V4.1 at 700 mA 85°C.

“By creating products eligible for the DLC Qualified Products List, cities and municipalities can receive rebates on their LED street lighting projects, while also



realizing the fast return on investment from using the most efficient emitters," said Danielson. Furthermore, the LUXEON MX leverages a new, robust package that dramatically increases the projected lumen maintenance compared to the LUXEON M. The LUXEON MX is an instant upgrade to the LUXEON M, featuring identical footprint and optical characteristics.

The LUXEON MX multi-die emitter will be offered in a range of color temperatures (3000 K to 6500 K) and CRIs (70, 80 and 90) in convenient 3 V, 6 V and 12 V configurations. Applications include roadway lighting, street lighting, stadium lighting and high bay fixtures. ■

## LG Innotek - World's First 70 mW UV-C LED

LG Innotek recently announced that the company has developed the world's first 70 mW UV-C LED for sterilization applications. As its sterilization performance is 1.5 times higher than the competitor's 45 mW module. UV-C LEDs produce a wavelength in the range of 200 – 280 nm, allowing it to be used for sterilization purposes. It prevents the proliferation of bacteria by destroying their DNA.

Until now, UV-C LED has been mainly applied in small sanitary products because its low optical power led to low sterilization performance. The power of LEDs for toothbrush sterilizers is 1 mW and that for sterilizing the water tank of humidifier is 2 mW.

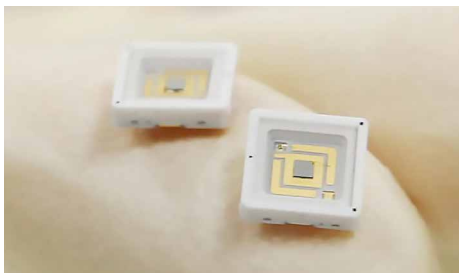

**LG Innotek's 70 mW UV-C LED package (6060 series)**

LG Innotek improved UV-C LED's optical power to 70 mW by utilizing its proprietary LED vertical chip technology. While the product measures only 6 mm in both its length and width, its sterilization performance is the world's best. The company overcomes the UV output limit with specialized LED chip technology. The epitaxial structure design and vertical chip technology to maximize light extraction have increased the output and ensured quality reliability by effectively exhausting heat.

As the company's product is compact and boasts high sterilization performance, it can be applied to various fields such as water purifier and air purifier. It is also good for use in hardening equipment in the manufacturing industry. As the UV output is strong, the performance of the curing device can be enhanced. Manufacturers of water purification, cleaning and curing device can benefit from stable supply of UV-C LEDs optimized for respective purposes. LG Innotek is equipped with a consistent production system that produces Epi-wafers, chips, packages, and modules, and offers its products to its customers after rigorous quality management.

Along with its 280 nm UV-C LED, LG Innotek has a lineup of LEDs from 365 nm, 385 nm, 395 nm, and 405 nm UV-A LEDs for general industrial purposes to 305 nm UV-B LEDs for bio and medical purposes.

Ho-rim Jung, the vice president of LED marketing division said, "We are expecting expansion of UV-C LED application field by developing 7 0mW product." and "We will continue to show high-quality innovative products." ■

## RayVio's 60 mW UV LED Sets Industry Benchmark for Disinfection

RayVio Corp., an advanced health and hygiene company, is delivering the industry's first 60mW UV LED in volume. The breakthrough performance from the company's XP Series is making the use of ultraviolet LEDs for critical medical and public health solutions a reality.



**XP Series UV LEDs can replace mercury lamps for water purification and sanitization against bacteria, viruses and superbugs like MRSA**



fresnel, diffractive, lenses, dif-  
fuse, silicone, individual, as-  
pheric, cylindrical, prototypes,  
led-optics, strainless, arrays,  
spheric, plastic optics, design,  
production & development



[www.imos-gubela.com](http://www.imos-gubela.com)



**Get in contact!** [info@imos-gubela.de](mailto:info@imos-gubela.de) / +49 (0) 7843 99511-0

IMOS Gubela GmbH • Kniebisstraße 1 • DE-77871 Renchen

With RayVio's XP Series, disinfection of flowing water, whole room sterilization and purification of household products and medical instruments can be achieved safely and efficiently without the use of fragile and hazardous mercury lamps. Even "superbugs" like MRSA can be safely and effectively rendered harmless.

"The global need for clean water, sanitary environments and protection against infectious disease is critical," said Dr. Doug Collins, RayVio's CTO.

With the 60 mW output from RayVio's XP Series, it is finally possible to address some larger scale infrastructure problems, like the disinfection of running water with a safe, efficient and long-lasting solution.

"The first ever sterilizing pod – Ellie – is just one example of how little time it takes to improve lives with our UV LED technology," said Collins. "Ellie can sterilize baby bottles, purify water and sterilize surfaces on pacifiers, keys and more to keep children safe from germs." ■

## Reliable LED Modules for Industrial Applications Under Harsh Conditions

Warehouses, factories and multi-story car parks all need robust luminaires that provide high lumen values. Industrial lighting has to be energy-efficient and durable. Tridonic offers the right LED light sources for diffused lighting in the form of its CLE G1 ADV IND and QLE G1 ADV IND modules. A luminous flux of 26,000 lumen per module and three different color temperatures of 4,000, 5,000 and 6,500 K make it easier to develop and manufacture LED high-bay luminaires for industrial applications.



Tridonic's latest LED modules are designed to withstand harsh conditions in various industrial applications like car parks or warehouses

Industrial environments place special requirements on lighting systems. Critical atmospheres and long operating times impose heavy demands on any lighting system, and maintenance is often associated with major effort and high costs. The luminaires are often difficult to access so production is disrupted and machinery has to stand idle.

The following four examples illustrate the specific demands of these situations and the benefits of LED lighting. Long-life components with high light output reduce the number of luminaires needed and the maintenance costs in high-ceiling rooms. In production facilities, high quality of light and high Illuminance lead to an increase in productivity and also help improve safety and reduce errors. In cold rooms, a good lighting system should operate reliably and provide full luminous intensity within only a short time despite low ambient temperatures. In multi-story car parks, the lighting components need to be energy-efficient and durable, with low maintenance costs.

For such applications, Tridonic combines the benefits of the indoor segment with those of outdoor products. This results in LED solutions with high efficiency, low standby losses and increased dielectric strength for extended temperature ranges. LEDs modules are perfect replacements for fluorescent and HID light sources as they meet the requirements for industrial lighting. The round CLE modules provide uniform illumination. They are suitable for use in wall lights, for example. The rectangular QLE modules are also suitable for ceiling luminaires.

Offering a luminous flux of 26,000 lm, they were developed for luminaires designed to be installed at ceiling heights of up to 16 m. They are based on standard boards, and luminaire manufacturers can therefore add them to their portfolios without the cost of developing new optics. The modules offer a high module efficiency of up to 153 lm/W ( $t_p=85^\circ\text{C}$ ). Reproducible color rendering is specified as MacAdam 3. Tridonic offers an 8-year guarantee on the modules, which have a nominal life of 100,000 hours.

Luminaire manufacturers will be offered drivers compatible with the LED modules. LED Drivers from Tridonic for industrial applications are designed to reduce stress on the modules so they achieve long service lives (thermal load/peak voltage). The LCI 100W–1050mA OTD EC driver with over

temperature protection and overvoltage protection up to 6 kV (between L/N and earth) is suitable for the CLE ADV IND module, for example. ■

## Adura LED Solutions' Horticulture LED Modules with Cree's HE LEDs

Adura LED Solutions, a global leader in LED module design and manufacturing based in Southern California, announced the launch of the new series of LED grow light modules. Both of Adura's new-generation LED grow light modules (1966-GLA and 1950-GLA) are using the latest generation of Cree LEDs.



For their new, highly efficient LED grow light modules, Adura LED Solutions counts on the quality and efficacy of Cree's HE LEDs

"These Grow Light modules deliver dramatic power savings and unmatched product reliability compared to the older generation. The modules offer low power, high-efficiency, best in class thermal performance using Adura's patented SinkPAD-II MCPCB technology, homogenous light distribution at precisely the right wavelengths and color ratios needed for superior photosynthetic response," said Abdul Aslami director of sales & marketing at Adura LED Solutions. "In horticulture application, LED lighting is most effective when the spectrum and level of the light are exactly tuned to the particular crop and growing conditions".

Plant growth is a function of photosynthesis. The spectrum of Grow Light modules is tuned to the plant-growing task and plant light has photons from the blue to red (400–700 nm) part of the spectrum. Different plants have different light needs. Adura LED Solutions offers standard and customized modules dedicated to a combination of spectrum, intensity, uniformity and light distribution. Solid-state electronics brings the same advantages to agriculture as it has brought to all other industry segments it touches. ■



## LED Engin LuxiTune 2.3 with BLE Control Interface

Combining a compact form factor with the latest platform features, the LuxiTune™2.3 tunable white light engine announced by LED Engin, Inc., targets the same track-lighting and small down-lighting applications as its Gen 2.0 products, while delivering the added performance and controllability benefits that were introduced with Gen 3.0. These advances, which include smooth deep dimming to 0.5%, no e-flicker and no visible flicker, also extend to additional control interfaces for DALI, DMX-RDM and Bluetooth Low-Energy (BLE) through daughter cards, that customers can chose to wire into their fixtures.



**LED Engin's LuxiTune 2.3 replaces LuxiTune 2.0 products with improved efficiency and functionality**

LuxiTune 2.3 is a 46 mm diameter, 1100 lm, single-emitter light engine that provides a replacement for LuxiTune 2.0. The Gen 2.3 hybrid board takes advantage of the thermal performance characteristics of "dielectric in metal core" PCB technology to integrate both the emitter and 0-10 V driver in this more compact format. Besides bridging the gap between the Gen 2.0 and Gen 3.0 tunable-white solutions, LuxiTune 2.3 is also offered at a lower price so fixture manufacturers can derive the most value.

With wireless control becoming an increasing requirement, the LuxiTune BLE daughter-card designed with technology from Casambi, is key to enabling BLE mesh-networked lighting installations. The interface was developed to be compatible with LuxiTune's firmware and plug into the Gen 3.0 driver board and has been available for some time. LuxiTune installations can be commissioned and controlled using the Casambi App that provides an end-to-end solution. Now, of course, it also supports the LuxiTune 2.3 light engine, opening up an even wider range of smart-lighting possibilities. ■

## Universal Lighting Technologies Adds High Bay Modules to EVERLINE® Series

Universal Lighting Technologies, Inc., a global leader in commercial lighting and a member of the Panasonic Group, recently announced the expansion of its high-performance EVERLINE® LED line with the addition of the High Bay Module family. This 22 inch, dual-row design features a high-lumen output of over 7300 lumens at maximum current.



**Universal Lighting Technologies' latest member of the EVERLINE® Series for High Bay applications offer high efficacy, high lumen output and high robustness, even at high operating temperatures**

Developed to offer fixture designers a high efficacy module specifically designed for high bay lighting fixtures, the EVERLINE High Bay Modules provide excellent lumen maintenance with an L90 rating of greater than 50,000 hours while operating at temperatures up to 90°C. Two of these modules operating with the EVERLINE D23CC90xxxT-F family of drivers provide 12,400 lumens with a system efficacy greater than 130 lumens per watt (lm/W), making them ideal to be combined in multiples for high bay lighting fixtures, for both universal voltage (120-277 V) and high range voltage (347-480 V) applications.

"The High Bay Module is available with Correlated Color Temperatures (CCT) ranging from 3000 K to 6500 K, with conformal coating as a standard option, covering the growing demand of customer requirements we are now seeing," said Heath Martin, product manager for Universal. "The thermally conductive circuit board material and dual row LED spacing both help reduce the LED's operating temperature. This improves the lumen output and system efficacy, making them ideal for high bay fixture applications." ■



## LED DRIVER SUPER SMALL & FLAT

**IDEAL FOR FURNITURE, SPOTS COVE AND CABINET LIGHTING**

- CONSTANT CURRENT & CONSTANT VOLTAGE VERSIONS
- 3, 4, 6, 12 & 20 WATT
- SUPER SMALL FOOTPRINT, SUPER FLAT DESIGN
- OPEN CIRCUIT, SHORT CIRCUIT, OVERLOAD, OVER-TEMPERATURE PROTECTED
- SIMPLE INSTALLATION, WIRED OR SCREW TERMINAL
- UL8750, ENEC & CE CERTIFIED



**RECOM**  
LIGHTING

[www.recom-power.com/superflat](http://www.recom-power.com/superflat)



## Inventronics EDC Driver for India's Challenging Power Conditions

Inventronics is a global company that operates on a local scale in the communities it does business in. It works closely with customers to ensure it provides the correct driver for any application. Inventronics is pleased to announce the release of a 60 W series of constant-current LED drivers created specifically to handle the challenging power conditions in the Indian market.



**Inventronics' new EDC series LED drivers now contains an especially designed version to accommodate the challenging power conditions in the Indian market**

The new EDC series offers a high level of protective functions including Input Over Voltage Protection (IOVP) and Input Under Voltage Protection (IUVP). This helps protect against poor power quality supplied to the LED driver, which then protects the luminaire, resulting in less maintenance costs.

The new EDC-060S105STM is certified to BIS standards facilitating safety certification for the end user. Inventronics understands the struggles of the Indian electronic designer and offers a high level of market leading input protection capable of handling voltage swells up to 440 Vac for up to 48 hours. The EDC series provides an IP66 rating and is equipped with a compact metal case enabling them to protect against dust and particles and a high level of protection against water and humidity.

The EDC-060S105STM series includes 3 models of constant-current drivers that can supply up to 60 W at output currents from 700 to 1050 mA with a full-load efficiency up to 90%. The calculated lifetime of these drivers are 112,000 hours at 75°C. They operate from 140-305 Vac, are suitable for Class I Luminaires and have a Total Harmonic Distortion (THD) under 10% that reduces the pollution of the power grid. Production quantities of the EDC-060S105STM are available now. ■

## TRP Introduces New SelectSync LED Drivers

Thomas Research Products has introduced an entirely new family of feature-rich programmable LED drivers under the SelectSync name. These cost-competitive models offer a variety of new solutions for powering intelligent lighting devices. Thomas Research Products manufactures complete LED power and control solutions for OEMs and retrofiters.



**TRP's new range of programmable drivers is available for indoor and outdoor applications**

The SelectSync family includes programmable LED drivers with a variety of form factors and wattages to accommodate most OEM needs. Initial model offerings cover 25W, 30W, 40W, 50W and 75W power ranges and include indoor and outdoor applications. Every model is Class P Listed to increase customers' speed to market. Controls-ready versions feature auxiliary output to power a wide range of sensors and devices.

Along with settable output current, TRP's new drivers offer an advanced array of dimming options. They all include 0-10V dimming, while some models offer Schedule dimming or even DALI. Most models provide Dim-to-off capabilities. Other model-specific features include controllable NTC thermal fold-back, lumen maintenance and stand-by mode.

A key benefit of the SelectSync family is a better experience in programming drivers on the production line. TRP's universal configurator software has an advanced GUI interface designed for simplicity in manufacturing environments. The configurator includes a programming cradle that handles wired, USB and NFC programming for all models. The configurator will be forward compatible with the same ease of use for new SelectSync models as they are added to the product line.

SelectSync LED drivers from TRP provide a new level of performance, capability and flexibility for OEM customers. The company's

5-year warranty is standard. All high-performance LED Drivers from TRP offer high quality, long life, high efficiency and cost-competitiveness. ■

## Fulham's New Advanced LED Outdoor Drivers with IoT Management

Fulham introduces new LED outdoor rated drivers that are feature-rich including integrated IoT management for Smart City lighting. The advanced specification of the Fulham Workhorse Extreme LED drivers has compatibility with wireless, DALI and 0-10 V dimming which is flicker free down to 1% power. They also offer the widest available output current programming, so eliminating multiple driver stocking requirements.



**Fulham's new LED outdoor rated drivers are feature-rich and ideal for European lighting manufacturers looking for the very latest technology to drive all forms of exterior lighting luminaires**

Fulham's Workhorse Extreme LED drivers are IP65 rated, have integrated surge protection and come in 6 models from 40 W to 200 W. Each feature variable output current for ultimate flexibility in matching light source characteristics. Depending on the model, the drivers come in either very compact or linear case type.

An additional option available to luminaire manufacturers is integrated wireless management and control with the outdoor LED drivers. Here, Fulham works with Twilight to provide an integrated driver with wireless, cloud-based, IoT management and controls using the cloud to manage lighting for cities, utilities, airports, railways and other environments. Fulham's Workhorse Extreme LED drivers integrate with SkyLite, Twilight's intelligent wireless lighting control system and also other Zigbee-based systems.

By using the SkyLite IoT management platform or another Zigbee compatible platform, users can manage and monitor the health of the

Fulham outdoor LED systems. Using such management software, they can also set the output current for the LEDs remotely to reduce errors, extend the lamp's useful life, and simplify installation and maintenance. ■

## Infinion LITIX™ LED Drivers for Cost-Effective LED Front Lights

LEDs in automotive front lighting enable energy savings, new light designs and applications such as matrix beam and laser high beam. Supporting the progress in automotive lighting, Infineon Technologies AG launched high-power LED drivers specifically designed for automotive front lights. The drivers are available within the new LITIX Power Flex series and the LITIX Power series. They address flexible DC/DC driver solutions supporting LED systems of up to 50 W and even above. Application setups can vary: many medium-power LEDs with string voltages of up to 55 V or few LEDs with high currents of up to 3 A and more.



The LED drivers LITIX™ Power Flex and LITIX™ Power are specifically designed for automotive front lights. They address flexible DC/DC driver solutions supporting LED systems of up to 50 W

Both LED drivers, the LITIX Power Flex TLD5541-1QV and the LITIX Power TLD5190QV, are well suited for high-power and high-current LED applications. These include, for example, front lighting, and laser and LED headlamps. They also suit high-efficiency supplies for LED applications working on battery voltage. Furthermore, they allow cost-optimized full-LED front light applications for cars and even motorcycles with their space limitations in the handlebar's headlamp.

### Maximum LED system efficiency with LITIX Power Flex TLD5541-1QV:

The TLD5541-1QV is a first available member of the new multi-topology DC/DC controller family LITIX Power Flex. The synchronous H-bridge DC/DC controller is ideal for driving all high-power LED configurations with maximum system efficiency of well above 92 percent. This results in higher reliability and improved thermal behavior and reduced PCB size. Thanks to its optimized spread spectrum switching frequency, the TLD5541-1QV helps reduce EMC emissions to fulfill challenging EMC requirements like CISPR 25 class 5.

The TLD5541-1QV features seamless buck-boost regulation and fast dynamic load jump behavior. Therefore, it enables cost-optimized LED headlamps with complete protection and diagnosis features. Just one TLD5541-1QV can drive two and more separately switched LED loads in one string, with up to 55 V string voltage. The LED current accuracy is specified with +/- 3 percent.

**ELECTRO  
TERMINAL**

## OUR STRONG ONE. MICROCON SMDP



PCB connector for direct mains voltage supply to electronic PCBs within a lighting system. Marked types are available upon request.



### ALL ADVANTAGES AT A GLANCE:

- Clamping range 0.5 - 2.5 mm<sup>2</sup>
- Nominal current 16 A
- For solid and flexible wires
- Wires easily detachable with push-button
- For manual and automatic wiring
- Internally connected version available
- Top sided test opening provided
- Marking available



The TLD5541-1QV with built-in protection features and SPI interface offers both analog and digital (PWM) dimming. The switching frequency is adjustable in the range of 200 kHz to 700 kHz. The adjustable soft start feature limits the current peak as well as voltage overshoots at start-up.

#### LED system cost reduction with LITIX Power TLD5190QV:

The LITIX Power family of DC/DC converters and controllers targets medium-power to high-power applications. These comprise LED daytime running lights and LED low beam and high beam. The new family member TLD5190QV is a synchronous H-bridge DC/DC controller with similar features as the TLD5541-1QV. Without SPI interface it particularly suits LED control electronics where no microcontroller is needed, while it is easy to implement. The device also offers integrated protection functions, both analog and digital (PWM) dimming and an adjustable switching frequency in the range of 200-700 kHz. ■

## MechaTronix Launches First Horticulture Cooling Platforms

That horticulture lighting is hot these days is an understatement. The media attention, dedicated events and manifold speakers attracting listeners all point out that there is a big future (read capital) behind led lighting in the horticulture and agriculture sphere. All the players are preparing their strategies and products to earn a piece of the pie, and so is one of the thermal market leaders, MechaTronix from Taiwan.



MechaTronix's first cooling solution for horticulture is called CoolFin®, also available for 4 high power horticulture COBs up to 600 W

Koen Vangorp, CEO of the company said, "The thermal challenges and opportunities in horticulture lighting are from an unprecedented level and will definitely impact the future of

our company. Where MechaTronix started off with cooling of spot lights and down lights ranging from a few hundred to a few thousand lumen, they now end up in the era of kilowatts of energy losses which need to be cooled away, environments with extreme needs on temperature and humidity control, and nothing yet standardized on the market."

LED Emitter	Efficiency	Heat Loss
White	20-35%	65-80%
Royal/Deep Blue	65-70%	30-35%
Hyper Red	50-55%	45-50%
Far Red	40-45%	55-60%

It is interesting that independent of the power of a luminaire, the heat losses of horticulture LEDs are completely different to those from white lighting sources. While white corrected single emitters or COBs range from efficiencies of 20% up to 35%, horticulture LEDs with their specific wavelengths like royal or deep blue, hyper red and far red come at a complete different efficiency and resulting heat loss. A rough overview of a few variants shows that the heat losses in horticulture luminaires are depending on the color and wavelength mix, and are significantly less than in white light applications.

The power used per square meter or running meter is much higher in horticulture farming compared to for example a retail project. In horticulture farming we have to distinguish greenhouse farming from vertical farming or city farming projects. Without the extra daylight the power used per square meter easily goes up as far as 400 watts per square meter. Taken in account the losses seen above, that means that 200 watts of heat has to be cooled away, in a luminaire as small and lightweight as possible, with respect to the environmental needs like waterproof IP degrees. Looks challenging, but the energy saving effect in these power consuming environments only make the ROI's shorter and more worth going for it compared to the old technology.

Just a few months ago MechaTronix acquired heat pipe and thermosyphon specialist Cooling House from Taipei. Now a first example of horticulture LED cooling, the CoolFin®, is unveiling. The first model is a 600 watt ultra-compact light weight cooler based on advanced heat pipe technology. Reason for this choice was simple – a quick

market share with the ideal replacement for the current 1000 watt HID horticulture installed field.

The patented CoolFin® is developed in this way that it can either accommodate a board with multiple horticulture emitters in various wavelengths as well as a combination of 4 horticulture high power COBs up to 600 W. A spider construction of 22 high-end heat pipes lead the extreme thermal power away to a raster of light-weight stack fins. The complete design is IP67 waterproof resistant to withstand the moisture and dust levels relevant to horticulture environments. ■

## MechaTronix Launches 2x2MX LED Coolers

While standardizations have been mainly focusing on retail and indoor lighting applications, the field of industrial lighting is also undergoing a same movement. Availability of standard building bricks lead to a shorter time to market, crucial in the hectic lighting world of today. MechaTronix supports this trend with the release of its latest 2x2MX LED cooler platform.



MechaTronix's latest LED cooler platform serves standard LED engines for the 2x2MX platform that can be found from Lumileds, Osram or Adura Sinkpad with LEDs from a wide variety of manufacturers

One of the newest and most popular platforms used for outdoor lighting applications is dubbed the 2x2MX platform. 4 high power LEDs (typical 10W), 4 groups of mid power LEDs, or 4 COBs are placed in a square to generate 4000 up to 6000 lumen, and that in a size as compact as 96x96 millimeter. The complete LED engine is IP67 waterproof after assembly, what makes it utmost suitable for outdoor applications like high mast luminaires, industrial flood lights or street lights.

Standard LED engines for the 2x2MX platform can be found from Lumileds (Luxeon XR-M), Osram (P10 2x2MX), Adura Sinkpad (wide variety of boards with Cree,

Lumileds, etc.) and a further score of tier 1 suppliers. For the lenses a wide range of 2x2MX formats have been developed by Ledil, dubbed the Strada 2x2MX, with models made out of PMMA and made out of silicone in various beam patterns. Also LED COBs can be used on the platform instead of high power LEDs. With the CoolConnect® holder 2x2MX co-developed with Bender+Wirth in combination with the Cree CXB1512 or Citizen CLU028 4 COBs are mounted directly on the LED cooler. The extra advantage of this is that you lose the thermal resistance of the PCB board, what makes that you can go up to 6000 lm in this very dense platform!

Platform cooling was developed by MechaTronix and named the CoolBlock® SQ-01 2x2MX. This is a patented advanced pin fin cooler made by die casting with an electro plating specifically suitable for outdoor use.

An easy combination of multiple engines into a luminaire lead to endless lumen applications. The building block on itself is a proven concept, both from lighting as from a thermal point of view. Below is an example of a 48,000-lumen stadium light containing 12 2x2MX blocks. ■

## Electrolube Launch New Thermal Phase Change Materials

Electro-chemicals specialist, Electrolube will be demonstrating a range of capabilities and special products at this premier annual event for the global LED and solid-state lighting industries. Part of HK Wentworth Ltd and an established global manufacturer of electro-chemicals, Electrolube will have a strong presence at this year's Strategies in Light exhibition, where the company plans to show a range of

products designed to protect and enhance the performance of modern LED lighting products.



**Electrolube's new thermal phase change materials, TPM350 and TPM550, offer high thermal conductivity levels of 3.50 and 5.50 W/m·K**

The new thermal phase change materials, TPM350 and TPM550, offer high thermal conductivity levels of 3.50 and 5.50 W/m·K respectively. The low phase change temperatures encourage efficient wetting of the mating surfaces thereby ensuring minimal bond line thickness and reduced thermal resistance at the interface. Phase change materials provide an alternative to traditional thermal greases and both are silicone-free, have an operating temperature range of -40 to +125°C and are RoHS-2 compliant. These products do contain small amounts of solvent to improve wettability on application; this rapidly evaporates following application to leave the solid phase change material on the substrate.

Commenting, Ron Jakeman, Electrolube's Group Managing Director, said: "Our reputation and position within the LED lighting industry goes from strength to strength, which is owed largely to our R&D team, the consistent development of innovative new products and our well-earned reputation for problem solving. We work in conjunction with a number of prominent LED lighting manufacturers and end users around the world and have helped to solve many design and production related problems for our industry partners. One that

# EVERFINE

*Make every customer more satisfied*

## LED & Lighting Measurement Solutions



**LFA-3000 Light Flicker Analyzer**

- ◆ 100kHz Sampling Rate
- ◆ 0.1lx~200klx Dynamic Range
- ◆ Quantities Measurement and Classification As Per the IEC, CIE, IEEE, ASSIST, and California Title Requirements

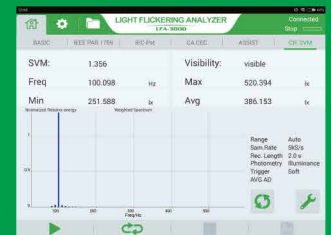

EVERFINE is a public company and provides all kinds of light & color measurement solutions for laboratories, production lines and lighting fields with quality products and professional services.



More  [www.everfine.net](http://www.everfine.net)

EVERFINE Corporation (Stock code:300306)

Tel: +86 571 86698333 (30 lines) E-mail: [global@everfine.net](mailto:global@everfine.net)  
 Add: #669 Binkang Road, Binjiang National Hi-tech Park, Hangzhou, China



immediately comes to mind involved a color shift problem experienced by one of our Indian manufacturing partners, which was resolved with the help of our UK based technical team. They recommended one of our low exotherm polyurethane resins specifically designed with LED applications in mind. Strategies in Light offers an excellent showcase for our products and expertise and we extend a warm welcome to visitors to come and join us at booth 223 and discover how partnering with Electrolube can help them improve their products' performance and reliability." ■

## TE Connectivity Introduces Poke-In Slim Wire Connectors

TE Connectivity (TE), a world leader in connectivity and sensors, has launched a series of Poke-In Slim Wire connectors that enable users to make wire-to-board and board-to-board connections quickly and easily.

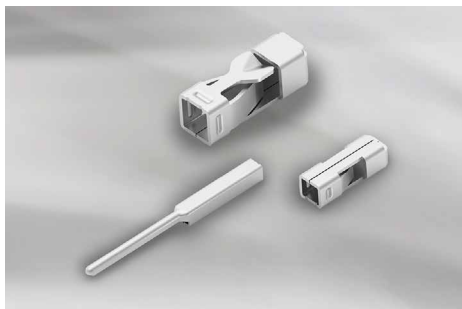

**TE's new poke-in connectors accept wire gauges 18-22 AWG**

The releasable poke-in contact function, along with a design that accommodates various wire sizes, allows for fast installation and rework; no special tools are required. Bare contact offers size and cost savings over housed poke-in connectors, with the new connectors' small footprints favoring compact PCB designs. Applications are primarily in LED lighting, building automation, telecommunications and security systems.

TE's new poke-in connectors accept wire gauges 18-22 AWG. The connectors are rated 10 Amps for 18 AWG wire and 6 Amps for 20-22 AWG. The slim male pin contact is designed for board-to-board connections with a 4 Amp rating when used with the releasable slim contact. Maximum voltage rating is 300 VAC. Operating temperature range is minus 40°C to 105°C. ■

## Electro Terminal Completes Range of Microcon SMD Power Connectors

The introduction of LED lighting has revolutionized the way lighting systems are designed. Simple "metal plates with electrical components" have been replaced by sophisticated electronic devices. Electro Terminal has developed the Microcon SMD Power connector to provide direct mains voltage supply to electronic PCBs within a lighting system. This connector is only 7 mm high and facilitates easy entry of solid and flexible wires of 0.5 mm<sup>2</sup> to 2.5 mm<sup>2</sup>. The whole range is out now – Microcon SMDP with one pole (1P), two poles (2P) and three poles (3P). In addition, the internally connected two-way version (2C) is available to limit the current load for daisy chain wiring on the PCB.

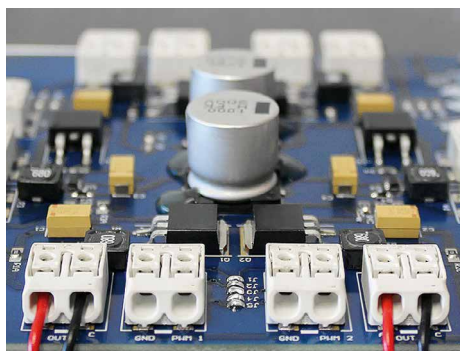

**Electro Terminal has developed the Microcon SMD Power connector to provide direct mains voltage supply to electronic PCBs within a lighting system**

All advantages at a glance:

- Clamping range 0.5 - 2.5 mm<sup>2</sup>
- Nominal current 16 A
- For solid and flexible wires
- Wires easily detachable with push-button
- For manual and automatic wiring
- Internally connected version available
- Top sided test opening provided
- Marking available

The Microcon SMD Power connector can be produced with a marking and has a test opening on the top. Wires can easily be released by pressing a push button. Tape-on-reel packaging enables automated connector assembly and SMT design makes wave soldering for connectors obsolete. Microcon SMD Power is perfectly suitable for driver-on-board solutions as well as very low-profile drivers with integrated power supply. ■

## BJB SMD Terminal Blocks for the Best Connection

SMD-compatible PCB terminal blocks are increasingly being used for electrical power supply to LED boards. This is because they are easy to handle and provide a permanent, secure connection to the control gear. A decisive factor for light quality is a design that is as flat as possible, which will enable an even light distribution and will avoid unwelcome shadowing. However, there are also technical requirements dictated by the relevant luminaire design. Examples are rear-entry wiring or the use of fine-stranded conductors. In order to cover every conceivable variation, BJB, the global market leader for lighting and luminaire components, has developed a series of three different SMD terminal blocks: SMD Mini, SMD Mini-Flex and the SMD push-through terminal block for rear-entry wiring.



**BJB's SMD terminal blocks with their universal range of uses are available as SMD Mini, SMD Mini-Flex and SMD push-through versions**

All three versions are designed by BJB as additions to the BJB OEM-Line, a modular system with fixing elements, connectors, lighting modules and optics for professional LED applications. The main advantage of the SMD terminal blocks is their universal range of uses. They can be fitted in practically all kinds of application in which PCBs are used. A feature of particular interest is that the two "Minis", with an overall height of only 4 mm, are so flat that troublesome shadows are largely eliminated. The push-through terminal block for rear-entry wiring has no protruding parts at all. Its terminals are on the rear side of the PCB and are therefore on the same level as the driver.

**Wires can be inserted and released again:** Each of the three terminal blocks can be supplied as a 1- or 2-pole version. As a result, they are flexible to use and can be placed in sequence without loss of poles. In general, they are suitable for both solid

conductors and tinned wire ends. With the SMD Mini-Flex, it is also possible to connect - and release - fine-stranded conductors through an insertion channel that can be opened wide with the aid of a contact opening device. Conductor cross-sections of 0.2 to 0.75 mm<sup>2</sup> are supported. In the cases of the SMD Mini and the SMD PCB terminal block for rear-entry wiring, conductors which have already been inserted can be released again without tools by simultaneously twisting and pulling. In addition to manual wiring, all SMD PCB terminal blocks from BJB are also suitable for automated processing. For this purpose, they are supplied in tape and reel packaging. ■

input various LED combinations and operating conditions to generate the spectral power distribution, photosynthetic photon flux (PPF), and power usage of a fixture using Lumileds LUXEON SunPlus Series LEDs.

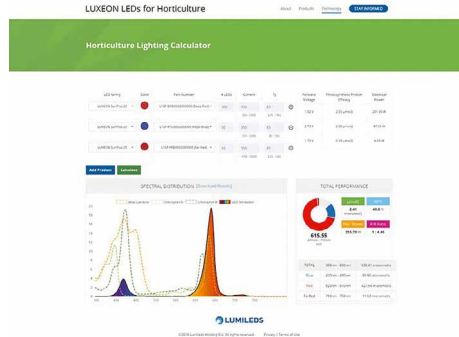

**Designers of grow lights for greenhouses, vertical farms and other horticulture applications can speed up their time to market by using this online calculator**

Designed to allow easy modifications of LEDs and operating conditions, the calculator facilitates fixture design by generating real-time feedback on spectral power distribution. Lumileds LUXEON SunPlus Series of LEDs are the only

horticulture LEDs on the market that are binned by PPF and wavelength to ensure ease of system design and enable wavelength tuning for maximum crop yield in both greenhouse and vertical farming environments.

“With the Horticulture Lighting Calculator, fixture manufacturers can test many lighting scenarios in a short period of time, so that their optimum designs can be brought to market much more quickly and efficiently than if each potential fixture were built and tested individually,” explained Jennifer Holland, Product Manager of the LUXEON SunPlus Series LEDs and Horticulture Lighting Calculator.

The LUXEON SunPlus 20 Line of LEDs is optimized for commercial greenhouses and uses 2.0 x 2.0 mm LEDs in Royal Blue (445 -455 nm), Deep Red (655-670 nm), Far Red (720-750 nm), Lime (broad spectra) and Cool White. The LUXEON SunPlus 35 Line is optimized for vertical farming, using Royal Blue, Lime, and three shades of Purple LEDs in 3.5x3.5 mm format. ■

## Lumileds Horticulture Lighting Calculator for Grow Light Development

Lumileds today introduced an online calculator that fixture manufacturers can use to more quickly optimize the design of their grow lights. The calculator allows the user to



Copyright©2017 Edison Opto Corp. All rights reserved.



## Dual Volt Flicker Free Circuit



### Features

- Flicker-Free Solution
- Work in a high voltage environment
- Triac / 0~10V Dimmer System
- High efficiency (110 lm/W)

### AC EdiLex Module

High PF  
Low THD



- Tunable
- Easy Dimming
- AC COB Module
- Triac Dimming
- Flicker-Free
- 0~10V Dimming

### Applications

- Indoor lighting



5/9~5/11 2017  
Visit us at Booth 1249



## Labsphere Launches Type D Benchtop Goniospectrometer

Labsphere, Inc. has released its newest light metrology solution, a full feature Type D Goniospectrometer that fits securely on a lab bench. Labsphere provides innovative solutions for a wide range of applications including LED/SSL lighting, remote sensing, imager/consumer camera, automotive, defense and security, health and biomedical optics to both Production and Research environments.



**Labsphere's Type D Benchtop Goniospectrometer offers uncompromised Type C Goniospectrometer performance at a reduced footprint**

Labsphere's Type D Benchtop Goniospectrometer is the perfect option for customers requiring the performance of a Type C Goniospectrometer, but is limited by lab space and budget. The reduced footprint allows users to benefit from Labsphere's expertise in light measurement technology without the hassle and expense of building an additional room for a traditional full size Goniospectrometer.

Greg McKee, Chief Technologist at Labsphere stated: "As we worked with global customers requiring full function Goniospectrometers, we realized that the industry needed a robust system that could be used in existing lab spaces. The Benchtop Goniospectrometer meets that need and augments the full line of light measurement technology solutions Labsphere has developed over the past 35 years."

The Benchtop Goniospectrometer measures: Lumens, Peak Candela, CCT, CRI, Beam Angle, Power, Power Factor and Lumen/Watt. User-friendly software allows for customizable reporting with over 20 data points reported in IES format for compliance to global standards and specifications. ■

## Ophir® Expands Series of Precisely Calibrated Integrating Spheres

MKS Instruments announces new additions to the Ophir® Integrating Sphere series of products. Designed for measuring divergent and collimated light sources, such as laser diodes and LEDs, the Ophir Integrating Spheres are integrating sphere and photodiode sensor systems for measuring the optical power of divergent, narrowband light sources. The series includes three precisely calibrated spheres that measure powers from 20 nW to as high as 30 W.



**IS-1, 3A-IS & IS-6 - the three new precisely calibrated integration spheres from MKS' business unit Ophir®**

### New Integrating Spheres:

- The IS-1 is a 1 inch (25 mm) sphere that measures powers from 20nW – 20mW for light sources from 350–1100 nm
- The 3A-IS is a 1.57 inch (40 mm) sphere that measures powers from 1µW – 3W for light sources from 350–1100 nm
- The IS-6 is a 5.3 inch (135 mm) sphere with 4-ports. It measures both high and low power divergent beams, from 20µ W to 30 W, for light sources from 200-2200nm

All three integrating spheres can measure beams with a divergence of up to ±40 degrees. Each is delivered as a calibrated unit with a photodiode detector. The IS-6 can be purchased with no detectors for use in the user's measurement setup or as a uniform light source. ■

## Ledvance Launches Substitube Connected

Ledvance, the fully-owned Osram subsidiary, is bringing the flagship of its current Substitube portfolio to market that enables energy costs to be reduced by up to 90% compared to applications with traditional

fluorescent tubes. The LED replacement for T5 tubes is also new to the portfolio, featuring real glass that prevents undesired expansion and sagging of the lamps.

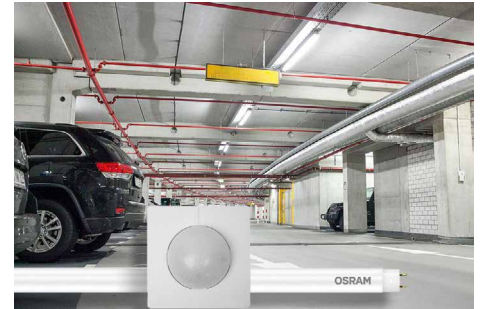

**The Substitube T8 Connected enables electricity costs for less frequently used areas to be significantly reduced**

The highly successful Substitube brand of LED tubes is now in its sixth generation and enables the direct replacement of fluorescent tubes. Until now these were able to save up to 69 percent in electricity compared to applications with traditional lamps. With the market launching of the "Substitube T8 Connected", Ledvance is now bringing the innovation highlight from last year's Light + Building to the wholesale sector. The product provides energy-saving potential of up to 90 percent in applications where fluorescent lamps were traditionally used - and up to 50 of these LED tubes can be wirelessly connected to a sensor detecting daylight and movement. The sensor dims the light as soon as it is not required and only a screwdriver is needed to adjust the sensor. The lamps are available with either 4,000 or 6,500 Kelvin color temperatures.

A further new product offered by Ledvance is the LED replacement for T5 tubes. To ensure the required level of stability in the luminaire this Substitube model is being launched to market with a real glass tube, optionally as the "Advanced UO" with up to 5,600 lumens for high rooms, or with up to 3,920 lumens for standard room heights. By simply replacing the light sources, electricity consumption can be cut by up to 50% compared to applications using fluorescent tubes, and in many cases payback times are less than two years. Both T5 replacement models have efficiency levels of up to 150 lumens/watt with a rated service life of up to 60,000 hours and 200,000 switching cycles. This lamp is also optionally available with 4,000 or 6,500 K.

The latest T8 models with the "Advanced UN" type designation can be used on both

conventional and electronic control gear without any additional precautions. This reduces stock keeping costs and enables greater scaling effects.

All Substitute LED tubes can be quickly and simply exchanged via plug & play and without new wiring – meaning that luminaire approval marks remain valid. The lamps also provide safe handling during mounting due to a special safety switch in accordance with IEC 62776. ■

## LumiGrow Cloud-Based Wireless Control Horticulture Lighting

LumiGrow has announced the worldwide release of the Pro Series E, a horticultural lighting product line that combines the best in optimized spectrum LED technology with cloud-based wireless control. Each Pro Series E fixture comes with a wireless control module included, so you can get up and running with the most modern lighting controls quickly and easily. Manage your lights from any phone, tablet, or computer via the SmartPAR™ Wireless Control System, and choose to be backed by the industry's best research support team running 10 years strong and leading 5-year warranty.



LumiGrow's Pro Series E horticultural lighting solution can be controlled from any phone, tablet, or computer via the SmartPAR™ wireless control system

"We've engineered our lighting solution with our customers' needs in mind. Our energy-efficient and intuitive design utilizes industry highest-efficacy LED's. We've increased light output (PPF/W), implemented robust and highly reliable components-drivers, and offer a user-friendly cloud-based software interface to further boost your bottom-line and overall performance," says LumiGrow Executive VP of Operations and Engineering, David Littleton at LumiGrow. "Our new product line empowers our users with ease-of-use and nimble response to changing conditions. Cloud-based wireless control allows for real-time adjustment of output intensity and spectral ratios for optimizing photosynthesis, achieving high yields, and improving commercial quality, all from your wireless device."

### Performance Meets ROI:

The Pro Series E product line takes advantage of some of the newest enhancements in LED technology, to provide more light output than their previous Pro Series, all while keeping energy-usage low.

# EPISTAR

Standing on the shoulder of giant

SEE FURTHER

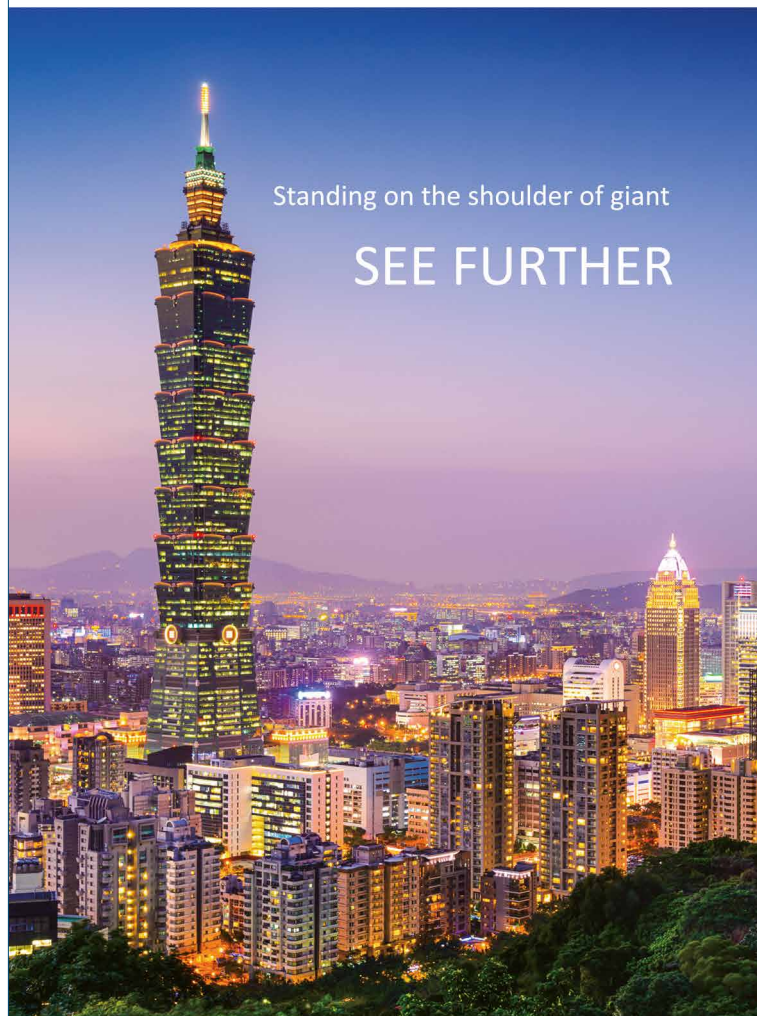

Co-activation  
**SERVICE**

Learn more about our  
Co-activation Service Model

### TAIWAN INT'L LIGHTING SHOW

Time April 12-15, 2017

Booth Area J 0326

Venue Taipei Nangang Exhibition Center, Hall 1

Epistar Corporation  
21, Li-hsin Rd., Hsinchu Science Park,  
Hsinchu 300, Taiwan  
T : +886 3-567-8000 F : +886 3-579-0801  
sales@epistar.com



Website Facebook



“When compared to standard HPS lamps, the Pro Series E typically pays itself off in electricity-usage savings within three years, with additional savings accrued each additional year of the fixture’s life.” says VP of Sales and Marketing, Jay Albere II. The new fixture delivers 50% energy-savings versus HID, runs up to 50% cooler than HID lighting, and maintains light output. LumiGrow also enables their devices with spectral control functionality so that you can achieve specific plant responses.

#### Grow How You Want:

No longer do growers need to be tied to rigid lighting arrangements and schedules. Take control of your lighting strategy by using SmartPAR™ Wireless Control System. Develop automated lighting schedules, adjust spectral ratios, and create lighting zones on the fly. Traditional lighting requires expensive wiring and infrastructure just to create and modify zones. SmartPAR™ frees growers to be more fluid with their growth strategies, enabling zone control, monitoring, and advanced spectral programs, all from any wireless device. ■

## Plessey Hyperion Family High-Power Horticultural LED Grow Lights

Plessey, a leading developer of award-winning LED technologies and manufacturer of solid-state lighting products, today launched the Hyperion family of high-power horticultural LED grow lights. Designed specifically to provide supplementary lighting in greenhouses, the Hyperion 1000 and Hyperion 1600 units deliver greater returns for commercial growers through increased productivity while achieving a 40% energy saving compared to equivalent 600 W and 1000 W sodium grow lights.



Plessey's new Hyperion high-power horticultural LED grow lights directly replace sodium lamps and cut energy by 40%

“Hyperion is the world’s most productive grow light,” said Jonathan Barton, Plessey’s Director for Grow Lights, adding, “As the only LED manufacturer to make LED grow light fixtures, Plessey has been able to use its LED design and engineering skills to create a superior solution that delivers a great commercial return for growers by also ensuring the lowest overall cost of ownership.”

Building on the success of its recently launched Attis range of grow lights, these initial Hyperion grow lights respectively deliver photon fluxes of 1000  $\mu\text{mol/s}$  and 1600  $\mu\text{mol/s}$ , and are ideally suited to growing vegetables, flowers, young plants and medical marijuana. They are directly equivalent to standard 600 W and 1000 W sodium grow lights. Hyperion units can be used to add to or replace existing installations. Plessey’s Hyperion grow lights provide a variety of spectrums to enhance yield, quality and consistency by controlling the speed of plant growth, flowering and fruiting – possibly extending crop production and product shelf life.



# Illuminating Innovation

## HOW CAN WE MAKE YOUR IDEAS BRIGHTER?

Dow Corning offers today’s LED industry unmatched experience and know-how for LED packaging and lamp and luminaire assembly. We bring more than just an industry-leading portfolio of assembly and optics materials – we offer you solutions for maximizing performance and enabling next-generation design. As your dedicated innovation partner, we also bring proven process and application expertise, a network of molding and optical experts, a reliable global supply base and world-class customer service.



To learn how Dow Corning silicones can address your key performance issues and turn your next-generation concepts into reality, visit [dowcorning.com/lighting](http://dowcorning.com/lighting).

#### VISIT US AT:

**LIGHTFAIR International**  
May 9–11, Philadelphia, PA, USA – **Booth 2557**  
**Guangzhou International Lighting Exhibition**  
June 9–12, Guangzhou, China – **Booth 1.1 D46**



Dow Corning is a registered trademark of Dow Corning Corporation. The Corning portion of the Dow Corning trademark is a trademark of Corning Incorporated, used under license. <sup>TM</sup> Trademark of The Dow Chemical Company © 2017 Dow Corning Corporation. All rights reserved.

AV23096, AV23015, AV19272

The 1:1 equivalence between Hyperion 1000 and Hyperion 1600 grow lights and the familiar 600 W and 1000 W sodium lights that growers, greenhouse builders and installers have been using for years, offers numerous benefits in evaluating, installing and using LED lighting. Comparisons between LED and sodium grow lights have previously been difficult because of the need to use more LED lights to match the light output of sodium lamps. For a given installation, the same number of Hyperion units can be used to directly replace sodium units, which would be far fewer than any competitive LED solution. The Hyperion units can also be installed on the existing greenhouse trellis. Hyperion permits greater lighting design flexibility with more even light distribution and less shading than alternative lower-power LED fixtures. ■

## Nanorod LEDs with Two Functions Could Make Multifunctional Displays

Cellphones and other devices could soon be controlled with touchless gestures and charge themselves using ambient light, thanks to new LED arrays that can both emit and detect light. Made of tiny nanorods arrayed in a thin film, the LEDs could enable new interactive functions and multitasking devices. Researchers at the University of Illinois at Urbana-Champaign and Dow Electronic Materials in Marlborough, Massachusetts, reported the advance in the Feb. 10th issue of the journal, *Science*.

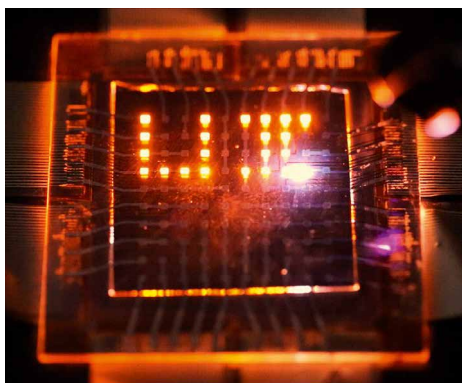

A laser stylus writes on a small array of multifunction pixels made by dual function LEDs that can both emit and respond to light (Photo courtesy of Moonsub Shim)

“These LEDs are the beginning of enabling displays to do something completely different, moving well beyond just displaying information to be much more interactive

devices,” said Moonsub Shim, a professor of materials science and engineering at the U. of I. and the leader of the study. “That can become the basis for new and interesting designs for a lot of electronics.”

The tiny nanorods, each measuring less than 5 nanometers in diameter, are made of three types of semiconductor material. One type emits and absorbs visible light. The other two semiconductors control how charge flows through the first material. The combination is what allows the LEDs to emit, sense and respond to light.

The nanorod LEDs are able to perform both functions by quickly switching back and forth from emitting to detecting. They switch so fast that, to the human eye, the display appears to stay on continuously – in fact, it’s three orders of magnitude faster than standard display refresh rates. Yet the LEDs are also near-continuously detecting and absorbing light, and a display made of the LEDs can be programmed to respond to light signals in a number of ways.

For example, a display could automatically adjust brightness in response to ambient light conditions – on a pixel-by-pixel basis.

“You can imagine sitting outside with your tablet, reading. Your tablet will detect the brightness and adjust it for individual pixels,” Shim said. “Where there’s a shadow falling across the screen it will be dimmer, and where it’s in the sun it will be brighter, so you can maintain steady contrast.”

The researchers demonstrated pixels that automatically adjust brightness, as well as pixels that respond to an approaching finger, which could be integrated into interactive displays that respond to touchless gestures or recognize objects. They also demonstrated arrays that respond to a laser stylus, which could be the basis of smart whiteboards, tablets or other surfaces for writing or drawing with light. And the researchers found that the LEDs not only respond to light, but can convert it to electricity as well.

“The way it responds to light is like a solar cell. So not only can we enhance interaction between users and devices or displays, now we can actually use the displays to harvest light,” Shim said. “So imagine your cellphone just sitting there collecting the ambient light and charging. That’s a possibility without

having to integrate separate solar cells. We still have a lot of development to do before a display can be completely self-powered, but we think that we can boost the power-harvesting properties without compromising LED performance, so that a significant amount of the display’s power is coming from the array itself.”

In addition to interacting with users and their environment, nanorod LED displays can interact with each other as large parallel communication arrays. It would be slower than device-to-device technologies like Bluetooth, Shim said, but those technologies are serial – they can only send one bit at a time. Two LED arrays facing each other could communicate with as many bits as there are pixels in the screen.

“We primarily interface with our electronic devices through their displays, and a display’s appeal resides in the user’s experience of viewing and manipulating information,” said study co-author Peter Trefonas, a corporate fellow in Electronic Materials at The Dow Chemical Company. “The bidirectional capability of these new LED materials could enable devices to respond intelligently to external stimuli in new ways. The potential for touchless gesture control alone is intriguing, and we’re only scratching the surface of what could be possible.”

The researchers did all their demonstrations with arrays of red LEDs. They are now working on methods to pattern three-color displays with red, blue and green pixels, as well as working on ways to boost the light-harvesting capabilities by adjusting the composition of the nanorods.

This work was supported by a collaborative research effort between the Dow Chemical Company and the University of Illinois, with the aim of advancing technologies important to industry. The National Science Foundation also supported this work. ■

### References:

The paper “Double-heterojunction nanorod light-responsive LEDs for display applications” is available from [scipak@aaas.org](mailto:scipak@aaas.org)

Images, an audio Q&A and a video demonstrating various functionalities are available:

<https://uofi.box.com/v/multifunctionLEDs>



## CTI Project Results Promise a Bright Future for OLEDs

Developing a low-cost, efficient method of increasing the attractiveness of OLEDs for lighting poses a significant challenge. Thanks to a CTI project, CSEM and Sefar AG have succeeded in designing a promising state-of-the-art way of achieving this aim. This technology opens up new opportunities for applications in residential, architectural, professional lighting segments, as well as consumer electronics.

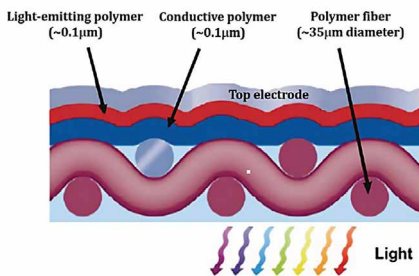

**Schematic cutaway view of the fabricated OLED device: Micrometer-size conductive metal wires and transparent polymer fibers are woven together and embedded into the optically clear filling polymer**

OLEDs (Organic Light-Emitting Diodes) have long been deemed to be the lighting technology of the future. However, their market penetration remains minute due to their high production costs and moderate light output compared to, for example, inorganic LEDs.

Considerable resources have been applied, unsuccessfully, to overcoming these barriers. Thanks to a project supported by the Swiss Confederation (CTI project), CSEM and the company Sefar are now able to propose a promising solution featuring interesting production costs, high efficiency, and compatibility with the fabrication of large-area OLEDs.

### Low-cost, flexible, highly transparent but still highly conductive:

Together, the partners have developed low-cost, flexible, transparent, highly conductive electrodes made of fabric substrates comprising flexible metallic wires and polymeric fibers woven together in a highly transparent and flexible polymer. These fabric substrates (SEFAR® TCS Planar) are manufactured using low-cost, high-throughput processes under standard ambient clean room conditions.

The OLEDs are finalized by coating the substrate with a thin-film (tens of nanometers) layer of a solution-process conductive polymer. The high electrical conductivity of the metal wires in the fabric substrate ensures that the electrode displays high conductivity over large distances, even with an ultra-thin, and hence highly transparent, layer of the conductive polymer.

“The wet deposition of the different ultra-thin OLED layers with excellent thickness uniformity and minimum leakage current

was the main challenge faced by CSEM,” explains Rolando Ferrini, Head of CSEM’s Integrated Light Management Section.

### Real, far-reaching potential for optoelectronic devices:

“The use of Sefar fabric-based electrodes significantly simplifies the production of large-area OLEDs by eliminating the evaporation, photolithography, and electrical insulation of the supporting metal tracks,” continues Peter Chabreck, R&D manager at Sefar. “With this achievement, our company aspires to reach 20 percent of the flexible transparent electrodes market by 2020 for all types of optoelectronic devices.”

The groundbreaking solution can be applied for OLEDs, as well as for many other products, including solar cells, EL devices, touch screens, electrochromic glasses, transparent heating elements, sensors, photo-detectors, and transparent shielding elements. ■

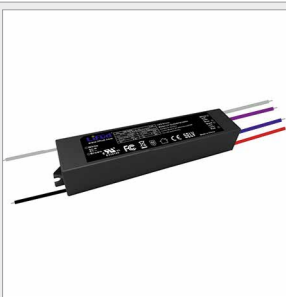

### IP65 + Flicker-Free + 0-10V / PWM / Rx Dimmable Lifud New LF-GLD\*\*YA Series

All designed in One Lifud’s Potted IP65 LF-GLD\*\*YA series extends its function with flicker-free and 0-10V/ PWM / Rx solution, covers a power range from 15-60 W. Mainly applied for LED linear lights, tri-proof lights, grid lights, floodlights etc. 100-277 Vac ( max. 90-305 Vac), 25-50 Vdc with high PF& EF and low THD.

For more details see [lifud.com](http://lifud.com) or visit us at Light Fair May 9-11 • Pennsylvania Convention Center, Philadelphia, PA USA Booth # 5724

**LIFUD**  
sales@ledfriend.com



### Product Showcase: 7-in-1 Single Channel 240W Constant Voltage Dimming Module

The GRE Alpha 7-in-1 dimmer provides full-range, 0-100%, smooth, high resolution dimming performance for constant voltage LED dimming applications. Flexible and easy-to install, this unit comes with a multi-colored LED indicator and integrated strain relief cover. Dimming transfer characteristics can be set (linear or logarithmic) for a wide range of dimming applications. Each unit includes built-in thermal shutdown with auto restart and overload protection.

<http://www.grealpha.com/>

**GREAlpha**  
LED Power Specialists

**NEW CREE® XLAMP® LEDs CAN:**

*IMPROVE RELIABILITY ::*

*REDUCE SYSTEM COST ::*

*REDEFINE LED LIGHTING ::*

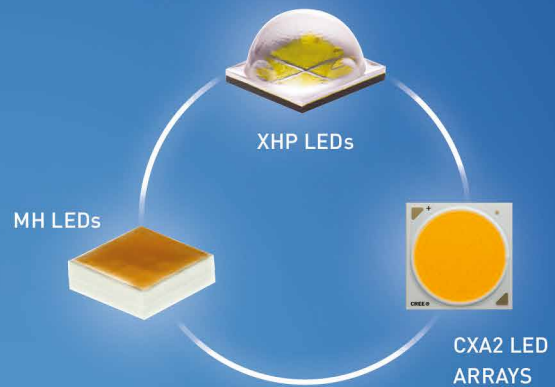

# GAME CHANGING IS GREAT. BOTTOM LINE CHANGING IS BETTER.

You can't change your bottom line by using the same LEDs that everyone else is using. Cree's Extreme High Power (XHP) LEDs deliver double the lumen output at high operating temperatures, while our MH LEDs combine the system advantages of our best arrays with the manufacturing ease of a discrete. And our CXA2 LED arrays are packed with lumens to offer system cost savings up to 60%.

**CREE** 

See how higher power equals lower cost.  
[cree.com/xhp](http://cree.com/xhp)

The new way to a better LED array.  
[cree.com/mh](http://cree.com/mh)

Even more lumens for savings up to 60%.  
[cree.com/cxa2](http://cree.com/cxa2)



## TECHNICAL REGULATORY COMPLIANCE UPDATE



Segment	Product	Standard (Certification)	Region	Technical Regulatory Compliance Information
Lighting	Tubular Fluorescent Lamps	Standard TIS 23-2558, 2015	Thailand	<p>The Thai Industrial Standards Institute (TISI) is the national standards agency, will be withdrawing the current Thai Industrial Standard TIS 23-2521 (1978), and replacing it with the new standard TIS 23-2558, 2015 and this comes in force on Dec 20, 2017.</p> <p>This new TIS standard is intended to increase the level of protection for human health and safety, and it references the international standard IEC 61347-2-8 (2000). It states the safety criteria for fluorescent lamp ballasts intended for use with AC voltages up to 1,000 V at 50 or 60 Hz, with or without pre-heated cathodes or a starting device, and also having rated wattages, dimensions and characteristics as specified in TIS 236 and TIS 1713.</p>
Lighting	Table Lamps for Visual Task	Standard CQC16-465316-2016	China	<p>China Quality Certification Centre (CQC) has modified the performance certification rules for table lamps for visual task. This is in force since Nov 02, 2016 and applies to tungsten, fluorescent or LED light source, the power supply voltage not exceeding 250V visual task lamps, including visual literacy work lamp and VDT visual task lamp.</p> <p>The modifications can be broadly seen in the below areas:</p> <ul style="list-style-type: none"> <li>• Certification scope</li> <li>• Certification criteria</li> <li>• Certification unit of classifying rule and Validity of the certificate</li> </ul>
Lighting	Double Capped Fluorescent Lamps	Standard TIS 956-2557, 2014	Thailand	<p>Mandatory double capped fluorescent lamps Thai Standard TIS 956-2557, 2014 approved on 29 September 2016 by TISI (The Thai Industrial Standards Institute), prescribes the general safety requirements for double-capped fluorescent lamps for general lighting purposes of all types with Fa6, Fa8, G5, G13, 2G13, R17d and W4.3x8.5d caps. It includes photobiological safety, blue light and infrared hazards below the level which requires marking and labeling. The Standard will enter into force after 365 days from the date of publication in the Official Gazette on 3 October 2017</p>
Electrical	Low Voltage Equipments	Decision No. 120, 2016	Customs Union	<p>The technical regulation of the Customs Union is developed in accordance with Agreement on common principles and rules of technical regulation in the Republic of Belarus, Republic of Kazakhstan and the Russian Federation of Nov 18, 2010. This technical regulation was adopted by the Board of Eurasian Economic Commission, Decision No. 120 which amends Decision No. 768 approving the Technical Regulations on Safety of Low Voltage Equipment.</p> <p>The technical regulation of the Customs Union is designed to establish a single customs territory of the Customs Union, a mandatory for the application and enforcement of the requirements for low-voltage, ensuring the free movement of low voltage equipment into circulation in the common customs territory of the Customs Union. This regulation is in force since Nov 26, 2016 and provides a new list of voluntary standards whose compliance may be used to demonstrate conformity to the technical regulation.</p>
Components	Plugs and Socket-outlets for Fixed Wiring, Adapters and Cord Sets	Announcement No. 10530006230, 2016	Taiwan	<p>The Bureau of Standards, Metrology and Inspection (BSMI) under the Ministry of Economic Affairs (MOEA) implements commodity inspection measures as stipulated in Taiwan's Commodity Inspection Law. This standard came into force on Dec 27, 2016 which is in accordance with the Commodity Inspection Act where plugs and socket-outlet for fixed wiring, adapters and cord sets are subjected to mandatory inspection.</p> <p>BSMI is revising the inspection standards of Plugs and Socket-outlets for fixed wiring and Adapters to enhance consumer protection. Also to add to the safety requirements for the commodities as stated before they require marking of presence conditions of restricted substances. All these markings should be made in accordance with Section 5 of CNS 15663(2013-07) on the body, packages, stickers or the instruction books of the product. Manufacturers and Importers who utilize website to announce "the presence conditions of the restricted substances," their website address should then be clearly stated on the body, packages, stickers or the instruction books of the product.</p>

**Disclaimer:** This information is research work of TÜV SÜD Product Service and is intended for general information purposes only. The content is publishable only after having the consent of TÜV SÜD Product Service. If it is published with any changes, the company is not liable for it. The information is subject to change and all rights for it are reserved by TÜV SÜD Product Service GmbH.

A free training can be arranged for a clear understanding of the upper stated standards. For further information on the latest upgrades and testing standards and training, please contact [cps@tuv-sud.com](mailto:cps@tuv-sud.com)

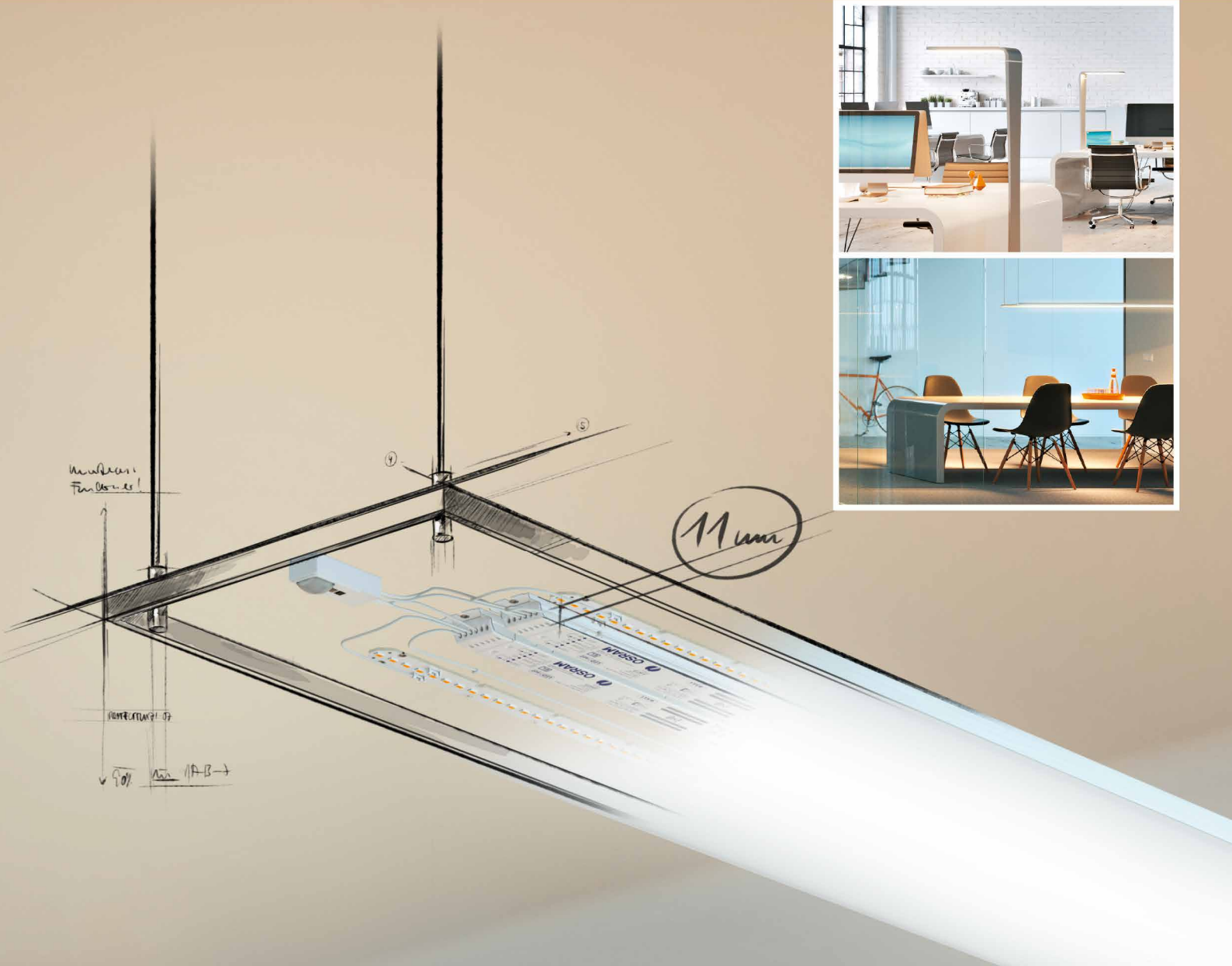

# Light is flat

## OSRAM UltraFlat-System

### Your design visions become reality

With a depth of just 11 mm, our UltraFlat DALI LED driver brings a new dimension to our wide range of OPTOTRONIC® drivers: flatness.

Teaming up with the PrevaLED® Linear Slim LED module and the small light and motion sensor, the UltraFlat driver enables you to realize designs that were not possible before. Slim luminaire designs can be achieved without compromising on high performance and functionality. Discover our multifaceted LED system portfolio to meet your unique requirements at: [systemsolution.osram.com](http://systemsolution.osram.com)

Light is OSRAM

# OSRAM



# Application of CIE 2015 Cone-Fundamental-Based CIE Colorimetry

CIE Division 1, Vision and Color, is responsible for studying visual responses to light and establishing standards of response functions, models and procedures for specifications relevant to photometry, colorimetry, color rendering, visual performance and visual assessment of light and lighting. In this article, the CIE 2015 colorimetry system is introduced followed by a description of key questions proposed by the CIE for future research needs on this important topic.

Among the standards developed by CIE Division 1, the CIE 1931 standard colorimetric observer, defined by the 2-degree CIE color-matching functions

$$\bar{x}(\lambda), \bar{y}(\lambda), \bar{z}(\lambda)$$

are the most important and fundamental functions that form the basis of CIE colorimetry. Even though the CIE 1931 standard colorimetric observer has been used as the international standard for more than 85 years, it is occasionally found that the colors of objects do not visually match even though their colorimetric values are the same. Additionally, there is strong evidence that there can be significant error in the current color specification

using the CIE 1931 standard colorimetric observer, especially when applied to some white LED light sources.

Since colorimetry was established in 1931, considerable improvements in the metrology of the color stimulus and immense advances in the knowledge of color vision have been made. Based on the modern knowledge of the human color visual system, the CIE published a set of new color-matching functions known as the CIE 2015 observer, which takes into consideration the age of the observer and the field size of the stimulus, and provides a method for deriving the associated chromaticity diagram (CIE 170-1:2006, CIE 170-2:2015).

## CIE 2015 Colorimetry

The CIE 2015 Colorimetry system was introduced in two CIE Technical Reports, CIE 170-1 and CIE 170-2, developed by CIE Technical Committee (TC) 1-36. Part 1 of the report introduces cone fundamentals for the normal observer, ranging in viewing angle from 1° to 10°, and Part 2 provides the tools to calculate the cone-fundamental-based tristimulus values,  $X_F$ ,  $Y_F$ ,  $Z_F$  and chromaticity coordinates,  $x_F$ ,  $y_F$ .

To develop the cone fundamentals for the normal observer in Part 1, it is recommended to use as the color-matching functions (CMFs) of Stiles and Burch (1959), excluding the values of  $b_{10}(\lambda)$  beyond 505 nm. Then the spectral sensitivity functions of

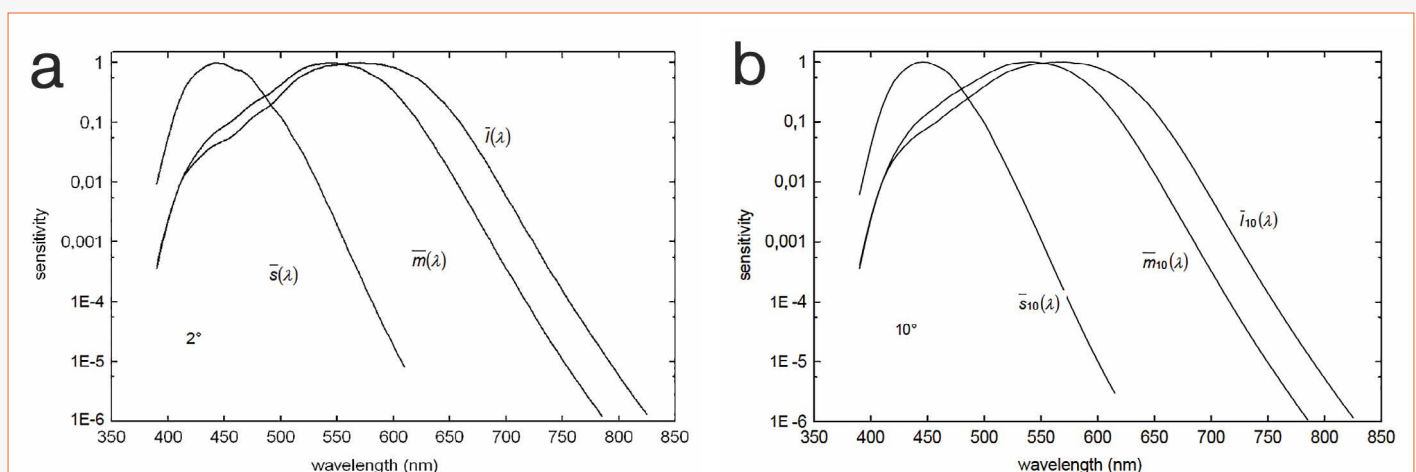

Figures 1a&b: The cone fundamentals for 2° viewing field (a: CIE 170-1:2006) and 10° viewing field (b: CIE 170-1:2006)

the long-wave sensitive (L-), medium-wave sensitive (M-) and short-wave sensitive (S-) cones, measured in the corneal plane for a 10° viewing field, the so called "cone fundamentals" are derived. Next, by correcting these functions for the absorption of the ocular media and the macular pigment, and taking into account the optical densities of the cone visual pigments, all for a 10° viewing field, the low density absorbance functions of these pigments were derived. Using these low density absorbance functions one can derive, considering the absorption of the ocular media and the macula, and taking into account the densities of the visual pigments for a 2° viewing field, the 2° cone fundamentals (Figure 1a). Using the same procedure one can derive cone fundamentals for every viewing angle between 1° and 10° (Figure 1b). Effects of age can also be incorporated by application of the relationship of the absorption of the lens as a function of age.

Part 2 of the report starts with the definition of cone-fundamental-based spectral luminous efficiency functions,  $V_F(\lambda)$  as a linear combination of the long-wave sensitive and the middle-wave sensitive cone fundamentals, following the proposal of Sharpe et al. (2011). Cone-fundamental-based spectral luminous efficiency functions are proposed for the 2° and for the 10° photometric observers. Then MacLeod–Boynton tristimulus values  $L_{MB}$ ,  $M_{MB}$  and  $S_{MB}$

are computed in the traditional form, while chromaticity coordinates  $l_{MB}$  and  $s_{MB}$  are computed so as to preserve the equi-luminant property of the diagram. In addition, transformations of the cone fundamentals in the form of cone-fundamental-based tristimulus values,  $X_{F_i}$ ,  $Y_{F_i}$ ,  $Z_{F_i}$  and chromaticity coordinates,  $x_{F_i}$ ,  $y_{F_i}$  are presented.

Figure 2 compares the spectrum locus of the cone-fundamental-based chromaticity diagram and that of the CIE 1931 chromaticity diagram.

More recently, CIE TC 1-97, **Age- and Field-Size-Parameterized Calculation of Cone-Fundamental-Based Spectral Tristimulus Values** has been established with the aim to recommend a procedure for age- and field-size-parameterized calculation of cone-fundamental-based spectral tristimulus values, compliant with the principles of the CIE XYZ concept and to deliver a computer program for the calculations.

### Future Research Plan

As introduced above, the CIE 1931 colorimetric system needs to be improved, possibly by adopting the CIE 2015 cone-fundamental-based colorimetric system for the calculation of colorimetric parameters to be used for the computation of lighting quality data. Therefore, intensive field trials

are required to help the color, imaging and lighting industries to gain confidence on CIE 2015 cone-fundamental-based colorimetry.

Firstly, the results of the use of the CIE 1931 (2°), CIE 1964 (10°) and CIE 2015 cone-fundamental-based color-matching functions, need to be compared, especially when applied to LED lighting and in imaging applications. How accurate are cone-fundamental-based colorimetry results compared with those of 1931 and 1964 in predicting typical colorimetry observations such as color difference, color appearance, whiteness, color rendering, etc.?

There is also a need to quantify observer metamerism. Evidence suggests that the earlier CIE method underestimates these effects. There is a need to investigate whether or not the cone-fundamental-based colorimetry could be used to quantify the age metamerism effect and/or the size metamerism effect. Also a recommended method for calculating the CIE 2015 cone-fundamental-based color-matching functions needs to be agreed upon.

The CIE 2015 cone-fundamental-based colorimetry system has established a better link between colorimetry and physiology. This link will improve the understanding of color, will be useful for education and will offer novel opportunities to solve problems of color measurement and color perception in everyday life and industry. ■

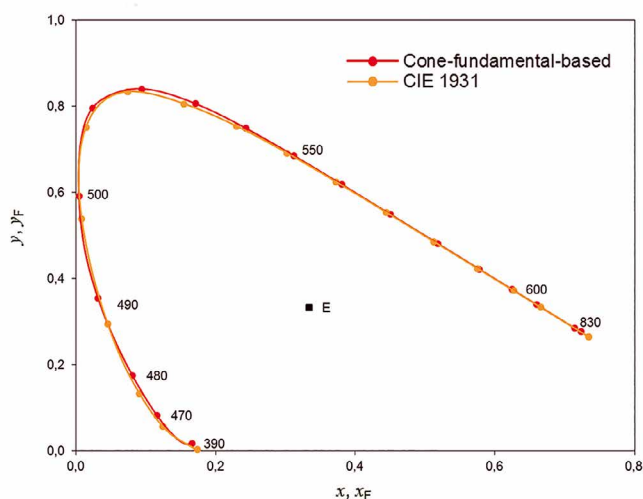

**Figure 2:** Spectrum locus of the  $(x_F, y_F)$  cone-fundamental-based chromaticity diagram (blue curve) and spectrum locus of the CIE 1931  $(x, y)$  chromaticity diagram (magenta curve) (CIE 170-2:2015)

### References:

- CIE 170-1:2006 Fundamental Chromaticity Diagram with Physiological Axes - Part 1
- CIE 170-2:2015 Fundamental Chromaticity Diagram with Physiological Axes – Part 2: Spectral Luminous Efficiency Functions and Chromaticity Diagrams
- SHARPE, L.T., STOCKMAN, A., JAGLA, W., JÄGLE, H. 2011. A luminous efficiency function,  $V^*D65(\lambda)$ , for daylight adaptation: A correction. *Color Research and Application*, 36, 42–46



# Tech-Talks BREGENZ - Norman Bardsley, President of Bardsley Consulting



## Dr. J. Norman Bardsley

Norman Bardsley is a member of the Technical Advisory Team for the Solid State Lighting (SSL) Program of the US Department of Energy (DOE).

In this role he is a co-author of the DOE'S SSL R&D Plan, helps to set the agenda for the annual R&D Workshop and manages research projects.

Norman also acts as Chief Analyst for the International SSL Alliance. Following the award of an M.A. Degree in Mathematics at Cambridge University and a Ph. D in Theoretical Physics from the University of Manchester, Norman served as Professor of Physics at the University of Pittsburgh,

Strategic Business Development Manager at Lawrence Livermore National Laboratory, Director of Roadmaps and Standards at the US Display Consortium and Director of Display Technology for DisplaySearch.

Professor of Physics, Dr. J. Norman Bardsley, has become an internationally recognized expert in SSL through his activities as an advisor for DoE and ISA. Dr. Bardsley has a profoundly deep knowledge and understanding of OLED technology, which includes the manufacturing thereof, cost structures and research activities. LED professional talked with him about the different aspects of OLED lighting technology and asked for his thoughts on future perspectives.

**LED professional:** Thank you very much for coming here to this interview. We'd like to start with questions about OLED if you don't mind.

**Norman Bardsley:** My pleasure. Go ahead!

**LED professional:** There was a time when all we heard about were OLEDs and how they were going to be the next light source. But it doesn't seem to have happened. In fact, a lot of big companies have sold their OLED businesses and the EU have stopped some incentive programs and reduced money for other programs. Given this environment, what is your general opinion of the OLED business?

**Norman Bardsley:** I think there's still a potential for OLED and other technologies that extend the form factors of Solid State Lighting beyond what's available now.

I'm very disappointed with the way that LEDs have been commercialized in the sense that most of the product developments and sales has been a light switch that looks and operates a lot like the original incandescent or discharge lamps. They are not in a form that takes full advantage of the Solid State technology. So, for example, for the last seven or eight years I've been very interested in the competition between OLEDs and edge lit light guides which are illuminated by LEDs. In my opinion both technologies have not progressed as rapidly as one had hoped. Although edge lit LED fixtures are now fairly common, especially in the U.S. They are still very thick and very heavy. You don't have the thin, lightweight flexible light source that we hoped would appear. So I think there is still an opportunity on the market for OLED.

**LED professional:** Can you identify some reasons why OLEDs did not evolve faster?

**Norman Bardsley:** There have been several problems. The major one is cost. And perhaps the most effective way to reduce costs is to manufacture in quantity and design new products, which build on the ones that are selling well and making profits - and that just hasn't happened.

While the EU put a lot of money into basic research in organic, plastic and printed electronics, the big companies haven't followed through in designing products and developing manufacturing techniques that use these technologies. As a result, a lot of effective and fascinating research done ten years ago is still widely untapped.

In the past 15 or 20 years, the first real breakthrough for printed or organic or flexible electronics is in OLED with OLED displays. This broad range of interesting technologies is coming to market. But the Asians have



OLED technology lags behind expectations in regards to cost reduction. Nevertheless, attractive opportunities offered by flexible OLED displays encourage development and raise market expectations. These developments could also have a positive impact on OLED lighting applications



OLED displays, including the flexible AMOLED displays for mobile devices are already competitive for high-end products. Alternatives like micro LEDs or nano LEDs don't seem to be realistic alternatives yet even though there are rumors that they'll be used in Apple's next generation mobile phone displays



brought it to market. I think that is because the Asian companies and the Asian governments have a different approach to supporting industry and research. They are prepared to go all the way to support them to knock others out.

So I think that the promise of OLEDs is still there but there has been very little progress for OLED lighting in getting the task done right. Since so much money is being spent, and so much development work is going into OLED displays, and now almost half of it goes into flexible OLED displays, the big hope is that this technology development might also be a chance for lighting.

**LED professional:** Why is the OLED display market so interesting nowadays that companies put more effort into them? I would think that you would only have one or two or maybe three screens in a household but you would have many more luminaires.

**Norman Bardsley:** Right. But there's a very big difference in the cost structure. OLED displays succeeded because Samsung found a product where the value of the end product was large enough to pay for a relatively expensive display. The display that goes into a cell phone in terms of dollars per square inch is maybe between ten and a hundred times more expensive than you can afford to pay for any lighting. And it is still not clear whether all that will be successful in other

display applications where the cost constraints are more severe. And you'll see this particularly in TV. The cost constraints in TV are almost as severe as in lighting. So one of my big hopes is that if OLED TV can compete in the mass market, not just the very high-end, then already the cost will have come down enough that it is much easier for companies selling OLED lighting.

**LED professional:** The next generation of iPhones is supposed to have a micro LED display with flexible substrates, and so on. There are new opportunities for using inorganic LEDs for these displays using some ideas that could be cheaper than OLED for flexible area illumination or something similar. Do you see a risk that this type of technology or approach will succeed before the OLED is really mature from a perspective of cost, technology and efficiency?

**Norman Bardsley:** Well, as I've already mentioned, I see no technical reason why edge-lit light guides may not provide a solution for very thin, light weight flexible displays. However, the LED industry hasn't been working very hard on solving the many problems that exist there. And micro-LEDs, at the moment, are like quantum LEDs: It's something that competitors are throwing out there just to show that they have a different idea. But I think that if you analyze them carefully - for example, Samsung have not yet

committed themselves to OLED TV and they keep saying that they'll go instead with Q-LEDs (quantum LEDs). However, as Barry Young has pointed out, quantum LEDs are probably at least a decade away from giving the performance that you need. Micro-LEDs are also very far from achieving what is dreamt for them.

It's extremely costly. Setting up the circuit is very expensive and it's very difficult to do. The other extreme is people at Apple argue that you use micro-LEDs on a much, much lower size scale in hand-held devices. But again - you're going over from currently having 20 or 30 or even a hundred LEDs in an Apple smart phone to something like 10 million micro-LEDs! And it seems to me that it isn't anything more than a dream.

**LED professional:** So, you're saying that it is much too early for things like quantum LEDs and micro-LEDs. Isn't that really the same thing that happened when the OLED was announced at the beginning of the new century?

**Norman Bardsley:** Yes, but we see that OLEDs have made a lot of progress since they were announced. I will admit, though, that the progress is nowhere near as fast as I would like to see it, especially in terms of developing products. But as you pointed out, there are less investments being made in basic research. It's an interesting question as to which will come to market first, but I think in respect to micro-LEDs and Q-LEDs, OLED is still way ahead. Of course for lighting, it's a different matter.

**LED professional:** About 10 years ago there was a very simple rule for OLEDs: 100 candela per square meter and about 1,000 hours lifetime or 1,000 candela per square meter and 100 hours lifetime. It has changed in the meantime, but we're still not where we want to be. What do you think are the chances for progress in both brightness and lifetime?



**EARLY BIRD TICKETS**  
AVAILABLE UNTIL JULY 3RD.  
[www.trends.lighting/event-registration](http://www.trends.lighting/event-registration)



FORUM | SHOW | NEWS

# SMART TRENDS IN INDOOR LIGHTING

**FROM HCL, TO LUMINARIES TO INTERNET OF THINGS**  
for Architects, Lighting Planners, Lighting Consultants  
and IT/IoT System Integrators

September **26-28 2017** | Bregenz  
[www.trends.lighting](http://www.trends.lighting)

Co-located with Europe's Leading Lighting Technology Event  
**LpS 2017** | [www.lps2017.com](http://www.lps2017.com)



The role-to-role manufacturing process is a key technology for the mass production of flexible OLEDs



**Norman Bardsley:** I think that there has been a great amount of progress during the last few years, for example, in the adoption of multiple stacked OLEDs. These are appearing in displays now but they started out in lighting where people started to have two layers, and then three layers – and then Philips came out with a bright product that has six layers. This means that if you have six layers, the current density is six times less. So the lifetime is maybe 10 times more.

You can do things with this: You can either keep the brightness the same and have a longer lifetime or you can raise the brightness. Roughly, if you double the brightness the lifetime decreases by a factor of three or if you triple it, it decreases by a factor of five. So you still have a trade-off.

There are a lot more serious problems, though. If you have an individual light, you don't notice a decrease by 20% but if you have two lights side by side, you do. Especially in displays with a question of persistence of image – then 3% or 5% is all they tolerate. So that's another area where there are benefits coming from displays and materials are being developed where lifetime is critical. The reason I brought this up is that at the moment, the amount of light that is put out by a single panel is still fairly small. So very often you have luminaires with multiple panels and then you have two panels next to each other. If there are two next to each other and you have a difference of 10% you'll notice it.

So luminaire manufacturers may demand something better than L-70. I don't think that what we have now is good enough.

**LED professional:** Another issue is the possible size of OLEDs today. I believe the maximum size of a standard OLED today is 32x32 cm and that is by far, not big enough for the ideas that some luminaire manufacturers or designers have. When do you think the technology will have evolved enough to get really large OLEDs?

**Norman Bardsley:** There are two aspects of this that interest me: One is that the most serious problem is the manufacturing one. If you're going to build really large panels, you either have to build them on a roll – role to role – or you need a very big substrate. Either way requires tremendous capital. And that's not available yet. Both Konica Minolta and LG Display have said for many years that they're going to build a new plant. LG Display may come online next year. Konica Minolta built one last year but it hasn't produced anything of commercial value yet. A big problem has been to scale up the size of the manufacturing facility.

Another related problem with manufacturing is yield. If you try to build one very large panel and you have a certain number of defects per square meter, that's much more difficult than making the same size panel out of relatively large number of small ones stitched together. So until the yield gets up to certainly

more than 80% and first handled panels, it's just not feasible.

**LED professional:** What about from a designing point of view?

**Norman Bardsley:** I think designers have been moving away from having whole homogeneous ceilings and walls. A panel can be very dull – unless you want to make it into a display. So, I would say there is less pull for large homogeneous than there used to be. But it would still be nice to have a variety of panel sizes. And another thing that's disappointing in terms of size is almost all of the panels that are made now are the circular or rectangular ones. Even the octagonal that Osram made have disappeared. Philips used to show lots of prototypes of flowers and Konica Minolta had the prototype of a tulip but they haven't appeared in commercial production, which is a shame.

**LED professional:** OLED is one thing but you need to have electronics to drive the OLED and you need to have something like a luminaire to put the OLED in. Today electronics have form factors, normally a square cross-section and very long. This is not the right form factor for OLED. You should have very thin driving electronics. Could you comment on that?

**Norman Bardsley:** Like you, I'm really frustrated at the size of drivers and the lack of availability of efficient drivers to meet any required luminaire design. But this is true on the LED side as well as the OLED side. My interest is really in getting thin, lightweight, flexible lighting and whether this is OLED or LED, I want a thin film electronic driver for it. I wish the Europeans and Americans would spend more time and effort in developing innovative drivers – and not just leave it to the Asians. It's a critical need but the problem is that there were small companies starting to develop the drivers ten years ago but there just isn't a market there to encourage them to put in the development work. I hope



While the light spectrum of OLEDs without a blue peak is an advantage for HCL, the lack of an affordable color tuning solution is a significant disadvantage

that this is something that will be recognized by the LED industry as a problem so we will get more progress towards more appropriate drivers and connectors.

**LED professional:** Another question is why should it be in the interest of the luminaire manufacturer to make luminaires out of OLEDs? All the value you create, is created by the OLED manufacturer and the electronics manufacturer.

**Norman Bardsley:** I think you have a good point and I've had a long argument with friends and colleagues in the OLED business, one of whom kept arguing that an OLED is a luminaire. I don't think so. Usually, the end price of a luminaire, even an OLED luminaire, has to be probably four times the cost of the panel. Now, maybe you could come down to two and a half, but it's got to be a lot more because of all the extra work you have to do or the design you have to make or the warranties you have to give and all the other expenses that luminaire manufacturers have. So I think it's unrealistic for an OLED panel manufacturer to expect that a luminaire company will come along and just add 10% to the price and sell it. I think it has to be treated like any other lighting component in that an LED in a luminaire is typically 10% to 15% of the cost and the driver is 10% to 15% of the cost. It's slightly different for an OLED. I think an OLED panel is 25% - but that's just what I envisage. And the driver

might be around 15%. The rest is there for the luminaire manufacturer to do what he has to do to make some profit.

**LED professional:** Another point is Human Centric Lighting and whatever one understands by that phrase. It is relatively simple to adapt color temperature or color in general with LEDs but not as easy with OLEDs.

**Norman Bardsley:** Some of the aspects of Human Centric Lighting are more easily met with OLEDs, for example, low temperature – minimizing the blue – and that's a big advantage. If you want to get a high color rendering, at the moment there's still a fairly substantial penalty for getting to CRI over 90 in LEDs. It's easier to do that in OLEDs. So if all you want to do is design a product for a specific application there is a possibility that OLEDs can compete in some markets, like health.

Dynamic control is much more difficult. This is one area where I think that OLEDs have not started to develop. Designing an OLED in which the color can be changed dynamically is something that can be done in the lab – there are ways to do it – but they are expensive. You can do it by having either red, green and blue stripes or pixels just as in a display. You can make them small so that they're not visible – but this means that you need three separate circuits that have to be

connected up – and the smaller you make them, the more expensive the circuit is going to be. Or you can stack them and put in intermediate electrodes and then you connect the electrodes up so you have the potentials across the reds, the greens and the blue are different. But again, that's a little more expensive to do. The other big problem there is with those intermediate electrodes that give you greater absorption because you usually get 10% or 15% absorption in a transparent conductor.

We know how to do it, but it's going to make it even more expensive and make the yield even lower in practice.

**LED professional:** You mentioned that an advantage of the OLED is not having the issues with the blue. But I'm not sure if we are discussing the problem correctly because the blue peak depends on the color temperature you use and on the quality, in general of the LED and the phosphors. A study that Osram did a few years ago showed that the blue peak doesn't mean that there is more blue than what there is in a fluorescent lamp. How correct are these figures?

**Norman Bardsley:** I agree with you that there is a lot of fear out there about blue light and I don't want to make the case that minimizing blue light is incredibly important. It's just that if a customer wants a light with a CCT of 2700 or 2000 than that makes OLEDs relatively more



Barrier layers that are also necessary to protect quantum dots on light guides belong to the most critical elements of an OLED

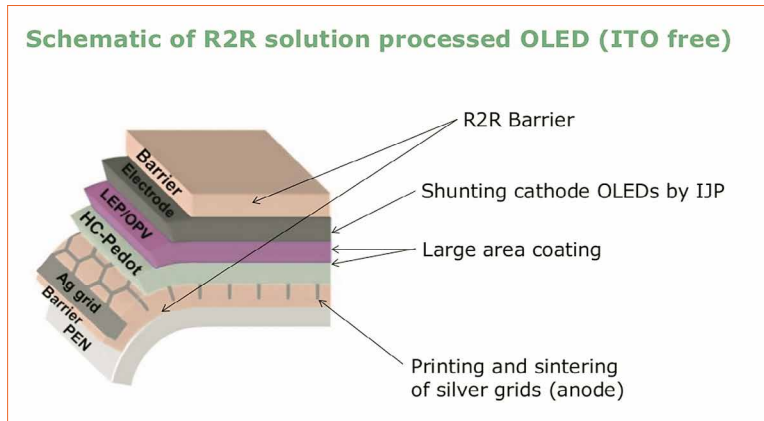

attractive than if he wants 5000 or 6000. I can't provide a solution – all I'm saying is that if you have a situation when you're using this light in the evening, an OLED is more attractive than it is for a luminaire to be used in a school or in an office.

**LED professional:** We discussed the need for special electronic technologies in reference to OLEDs. Do you think OLED technology will also drive other technologies?

**Norman Bardsley:** Ten years ago I was really hopeful that there would be a lot of synergy between organic photovoltaics and OLED. But it turns out that organic photovoltaics is proceeding almost as slowly as OLED. I can't point to a specific area where I think that something that we've learned in OLEDs will pay off. On the other hand, I'm always surprised when I go to these flexible and printed electronic meetings about how many new applications they have come up with. For example, I've been very frustrated with transparent conductors when we were looking for an alternative to ITO. The cost came down tremendously when it was found that the touch-screen people also needed a transparent conductor and then silver nano wires took off and were fairly successful.

**LED professional:** If we turn that question around – what areas do you see influencing OLED and maybe even other lighting technologies?

**Norman Bardsley:** My main area of interest has always been the overlap between displays and lighting. Right

now, for example, one of the areas where there has been tremendous progress in displays is quantum dots. When quantum dots were tried in lighting five to ten years ago it was found that the life-time was much too short because of the heating. But then in displays you can place them further away from the LEDs. So first of all QD Vision was very successful by putting in a strip of quantum dots on the edge of the display – a little further away from the LEDs – to convert the blue into the green and red or white. Then other companies put quantum dots on the surface of the wave-guide. That puts it even further away from the LEDs so you have less problems with heating but you need more of it. Both of those have been very successful. And now you have people looking back to see if you can use quantum dots as down converters in LEDs inside the package because of what's been learned about the lifetime. But that's not a cure. This is still an LED with a quantum dot replacing a phosphor.

Another area where there has been rapid progress is in the area of barrier layers for plastics that are needed for OLEDs. 3M had been working on developing such barrier layers. They have an effective solution but the market wasn't big enough for them to go into production. But then when the quantum dot people starting putting the quantum dots on the surface of the light guide they needed to be protected – because quantum dots need to be protected against water. And so the market was big enough. That's another area of what I think

would be potential overlap between OLEDs and large area electronics in general. If you have the need for electronics on plastic and you do need a barrier film, there has been a lot of progress and there will be even more progress in the next couple of years. So barrier film technology is an area that is progressing very rapidly right now and the cost is coming down.

**LED professional:** Just one more question: Do you see any other lighting technologies besides LED and OLED that might start to play an important role in the future?

**Norman Bardsley:** I'm not aware of any technologies or really of any need for a different technology. Q-LED is an example of something that could come but I'm not convinced that there's not any kind of lighting application or form factor that you can't meet with current SSL technology. The LEDs might have to be smaller or thinner or more efficient or they might have to have a longer lifetime but there are so many different ways now that are being developed for deploying LEDs, like chipless packages and COB and just a huge variety.

Furthermore, one of the big problems that OLEDs has had might also be true for other technologies. Luminaire manufacturers very often have said that they are so busy trying to learn how to use LEDs that they just don't have time for to take on something more difficult! And I think that we're going to have the situation for at least another decade that luminaire manufacturers are right to be focusing on optimizing and improving the solid-state technology that we have – including LEDs – rather than going off and finding something different.

**LED professional:** That statement could turn out to be the beginning of a brand new discussion! Thank you very much for your time.

**Normal Bardsley:** You're welcome. ■

# LpS 2017

**LED** SYMPOSIUM  
professional +EXPO

**! EARLY BIRD TICKETS**  
Available until July 3rd.  
[www.lps2017.com/registration](http://www.lps2017.com/registration)

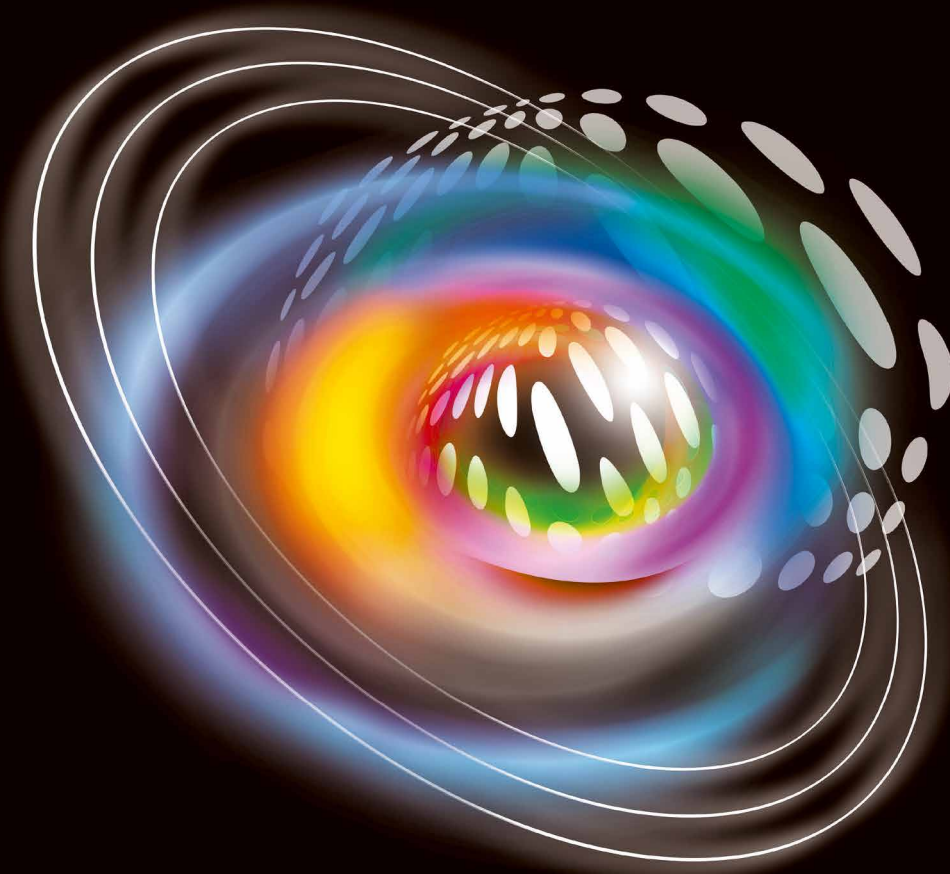

7<sup>TH</sup> International

## LED professional Symposium +Expo

Smart Technologies for Lighting Innovations



SEPTEMBER 2017  
26<sup>TH</sup> - 28<sup>TH</sup>

BREGENZ  
AUSTRIA

[www.lps2017.com](http://www.lps2017.com)



# Roadway Lighting Optics for Environment Adaptive Spatial Light Distribution

Roadway lighting for different environmental conditions is a challenging task. But even more challenging is to find a solution with outstanding task efficiency for both dry and wet tarmac surface conditions. The drawback of these types of solutions is that they are usually made up of two different lighting systems. Since the two systems are not usually used to an equal degree, they age at a different rate. Solving this problem is very complex. Viktor Zsellér, PhD student, and Dr. Krisztián Samu, Senior Lecturer, both from the Budapest University of Technology and Economics, propose an optical system that solves this conundrum.

This paper presents a method of generating artificial light distributions for European roadway lighting applications meeting every requirement of lighting standards. In particular, genetic algorithm is used for finding two optimized beam shapes for a defined lighting scenario with outstanding task efficiency, both for dry and wet tarmac surface conditions. Given these two light distributions, direct switching based on defined events is not recommended, as one chain will age faster, while some of the light sources are always turned off. However, simultaneously running the two optics, having the previously defined light intensity distributions is also impairing to any lighting situation, as the resulting light intensity to every spatial direction is a superposition of the two, forming this way a distorted cumulative with usually a bold nadir region.

The purpose of this paper is to introduce a separation method for these two, radically different light intensity distributions with

a user defined duty cycle scheme that minimizes the luminous flux variation during the lifecycle, providing a balance between the two chains. This way, two optical light engines can be designed, that are controlled to achieve the defined performance with aligned lumen depreciation, providing an outstanding lighting experience during various environmental conditions.

## Introduction

In roadway lighting applications where motorized traffic is involved, the installed luminaires must provide sufficient and uniform luminance on the roadway surface perceived by the drivers of vehicles while also controlling glare in order to ensure clear visibility of obstacles on the tarmac outside the stopping distance. While light intensity in specific directions can be considered a known parameter during the lifecycle of an outdoor lighting fixture and thus it is possible to achieve a good illuminance for a given task, luminance is heavily influenced by the reflection characteristics of the tarmac [1]. A fairly diffuse reflective surface becomes more specular reflective in case of rain that might result poor uniformity experienced by the observer and may even reduce contrasts below a certain level, so that obstructions become practically invisible in given areas.

For LED based roadway lighting luminaires the compact form factors of the light source, the advanced controllability with improved dimming capabilities and the robustness in optical beam shaping enables the application of an

	Isolines of Observer 2 [cd/m <sup>2</sup> ]		
	Reflectivity characteristics		
	Requirement	Standard CIE 30-2 R1 Tarmac	Standard W1 Tarmac
Lav [cd/m <sup>2</sup> ]	≥ 0.75	0.98	1.12
U0	≥ 0.40	0.75	0.34
U1	≥ 0.60	0.75	0.52
TI [%]	≤ 15	4	4
SR	≥ 0.50	0.66	0.66

**Table 1:** Recovering of the reported effects with lighting design calculations

environment adaptive lighting control scheme, where multiple channels of light sources with different optics are dimmed separately, transitioning the system level light intensity distribution between defined states. This function can either be utilized as just a switching profile triggered by discrete events like the rapid change of humidity, or as a closed loop control scheme processing the signals of even multiple kind of sensors or for instructions casted via telecommunication channels.

### A Lighting Design Case Study

In order to gain a better understanding of the problem statement, figure 1 shows an evaluation of the same street, which recently adopted LED technology – once while the tarmac is dry and again when the surface of the roadway is slightly wet. The reason of these investigations was residential complain, since the contrast revealing capability of this lighting installation drastically dropped upon rain. Moreover, it was also reported, that the reflected light intensity by these conditions caused disability glare, reducing the observers ability to determine the distance of obstructions and pedestrians.

After the characterization of the reflectance of the roadway surface, R1 property was used for dry condition and W1 for wet in the lighting design verification. This effect of luminance pattern change is becoming more cardinal by increasing the difference of specular-diffuse reflectivity ratio of the surface, meaning that diffuse tarmacs are more sensitive in this aspect. In addition, most roadway surface shifts towards being more diffuse reflective during its lifecycle.

It can be seen on table 1 that the lighting installation does not meet the specified requirements in case of wet surface. Both overall uniformity and longitudinal uniformity drops significantly while average luminance increases. This latter factor is caused by the increased specular reflected luminous intensity [2]. The largest luminance gain observable in one of the standard defined calculation grid on the field of calculation for luminance is 298% in this example.

One additional impact that is not reflected by the lighting design is glare. Threshold increment calculates with average road luminance and the uniformity is not considered in the calculation while the equivalent veiling

luminance is the same in both cases. Reporting glare with a threshold increment value of 4% was very unusual with traditional light sources like High Pressure Sodium.

### An Ideal Light Intensity Distribution for a Given Lighting Scenario

For the purpose of evaluation, two arbitrary light intensity distributions have been generated with genetic algorithm, both for the same roadway lighting scenario with dry and wet tarmac. Introducing this technique is important for the purpose of this paper, as the resulting desired light intensity distributions for this control method vary; and understanding this difference is a key for adapting this technique with acceptable level of mean square proportional error.

The algorithm provided finds a satisfying result for a lighting problem statement, while it is important to highlight that even though there is a convergence observable in the iteration process – it is not guaranteed that this way a theoretical absolute maximum will be found over the merit function.

**Figure 1:**  
The flowsheet of the light intensity optimization process

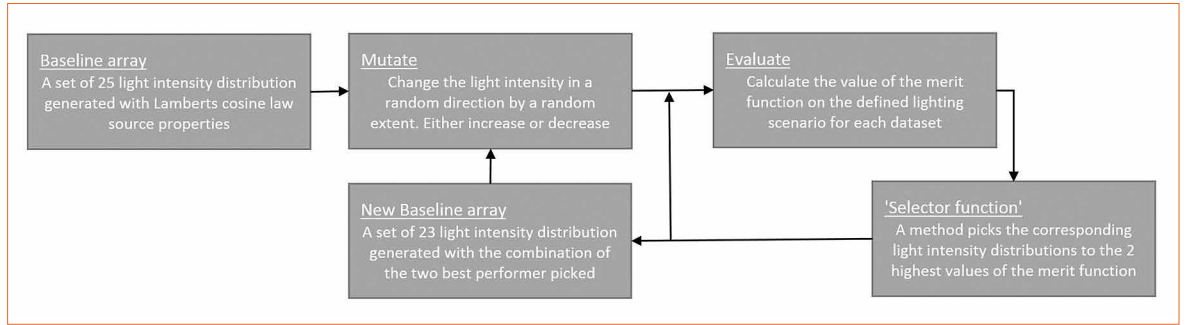

**Figure 2:**  
Transfer functions provided for the merit function

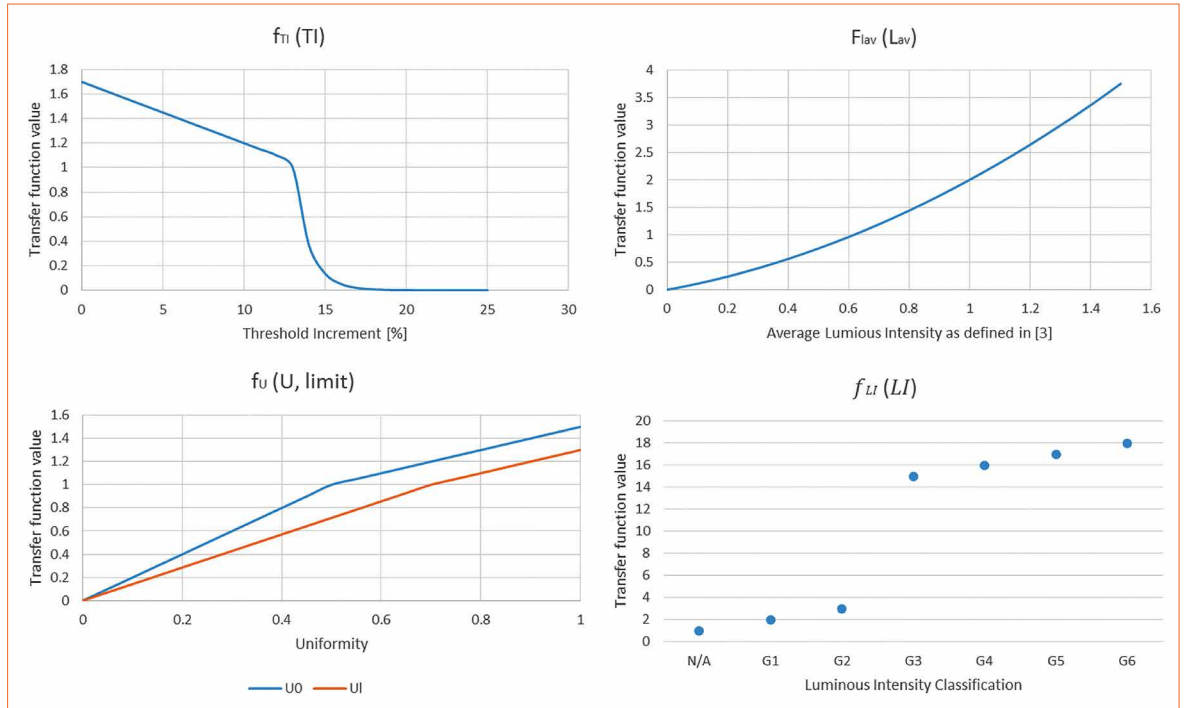

**Algorithm**

A light intensity distribution dataset consists of light intensity values typically in [cd] or [cd/klm] in a spherical coordinate system, defined as I-table. Positioning this in a virtual space enables the calculation of performance as defined in European Standard EN13201-3 [3] and illuminance characteristics. While such data arrays are usually acquired by goniophotometric measurements or by optical simulation, in this work purely arbitrary light intensity distributions have been generated. Reverse arithmetic calculation of illuminance tasks is easily programmable and has a wide spread literature – the same for roadway lighting arises complications due to higher order equations.

For the purpose of this paper, a population of 25 members of absolute light intensity distributions were created for each optimization with Lambert source characteristics as a baseline. In an iterative process, the light intensity towards a randomly selected spatial direction was increased or decreased by a defined extent in each step. Then evaluating the results on the defined lighting scenario against a merit function inherited from the requirements of European Standard EN 13201, the two best performing arrays have been elevated to the next iteration step, while the remaining population became the distortion of the mean derived from these two high performers. Figure 1 introduces the flowsheet of the optimization.

**Merit function**

Understanding the merit function used is a key in understanding the novelty of the method introduced. For function variables, a set of parameters have been calculated for the defined roadway lighting scenario. The iteration was designed to be converging to the maximum of equation 1.

Where *MF* is the merit function, and the variables used:

- L<sub>av</sub>: Average Luminance, [cd/m<sup>2</sup>]
- U<sub>0</sub>: Overall uniformity
- U<sub>l</sub>: Longitudinal uniformity
- TI: Threshold increment
- SR: Surround ratio
- LI: Luminous Intensity Class as integer (e.g. G3 is 3), derived from European Standard EN 13201, A.1

$$MF = f_{L_{av}}(L_{av}) \cdot f_U(U_0, 0.44) \cdot f_U(U_l, 0.66) \cdot f_{TI}(TI) \cdot f_{SR}(SR) \cdot f_{LI}(LI) \quad (1)$$



		Product A	Product B	Generated Light Intensity Distribution
	cd — C0 - C180 — C90 - C270			
Lav [cd/m <sup>2</sup> ]	≥ 0.75	0.94	0.75	1.26
U0	≥ 0.40	0.44	0.49	0.6
UI	≥ 0.60	0.61	0.66	0.92
TI [%]	≤ 15	10	6	14
SR	≥ 0.50	0.55	0.55	0.52

**Table 2:** Evaluation of the results on a sample lighting scenario

Figure 2 introduces transfer functions of Luminance, Uniformity, Threshold Increment and Light Intensity Classification used by the merit function for the evaluation of any given member of the arbitrary population. Every function needs to be monotonic for an appropriate level of convergence [4]. The resulting luminous intensity distribution is bilaterally symmetric and using high-resolution array results spikes towards the calculation grid points.

The need for luminous intensity classification was implemented in order to maintain integrity of similarity by the high angle light intensity outputs of the generated distributions for dry and wet tarmac, meaning that for a specific spatial direction, the ratio of the candela values is below a given threshold that will define the achievable dimming space. This way - using the ratios indicated on table 2 - D, it was possible to dampen the luminance gain effect above 70-degree vertical angle by highly specular reflective roadway surface. Even though this metric is only recommended to be calculated in case TI is not applicable, there are increasing numbers of high volume installations in EMEA, where a restriction of this rating is also demanded by municipalities.

**Evaluation of the results**

In order to benchmark the capabilities of the generator algorithm, a roadway lighting design was made to compare the performance with two commercial products light distribution at the same luminous flux, that are meeting

every requirement of a sample scenario with single row layout, 32 m pole distance, 10 m mounting height, no overhang and 8 m width roadway with R3 type tarmac.

**Two Channel Dimming**

The idea of two channel detached dimming requires two separate power supplies for the luminaire with individual dimming capability. These dimmers are to be connected to an intelligent module that is able to set the levels with high resolution over the dimming range. The actuating signal can either be gained from the data registered of specific sensors or acquired via telecommunication channels.

Let RA(C, γ) be the light intensity table (I-table) towards spherical angles C and γ of channel 'A', and RB(C, γ) be the luminous intensity provided by channel 'B' in the same direction, both in relative photometry. Let DA and DB be the dimming state of channels 'A' and 'B' and finally DD(C, γ) and DW(C, γ) be the defined light intensity distributions in domains [C, γ] for dry and wet tarmac conditions. Additionally a minimum luminous flux value needs to be assigned to the given relative intensity distributions that ensure

meeting the requirements of a lighting scenario with specified margin: φD and φW.

There is a general workflow for setting up a separation with this method:

- The user has to define the desired light intensity distributions: DD(C, γ), DW(C, γ)
- The minimum luminous flux has to be specified
- Three out of four dimming states need to be defined, which specifies the control scheme. The fourth value will be given based on the luminous flux specifications. Table 3 introduces the types that can be defined. Instance 1 is a type of control where the two channels are switched without dimming. Instance 2 dims down RA and dims up RB for the transition. Instance 3 dims up RB for the wet tarmac state. This is analogue to a system where in a reflective optic, portion of the light emitting surface is dimmed. Instance 4 is a system where the drive current is balanced
- A factorial optimization process has to be performed on two of the dimming specifications that minimizes the residual of the restored light distributions

	Instance 1		Instance 2		Instance 3		Instance 4	
	State D	State W	State D	State W	State D	State W	State D	State W
DA	100%	0%	100%	23%	100%	100%	70%	42%
DB	0%	100%	0%	70%	0%	100%	70%	100%
Target:	DD	DW	DD	DW	DD	DW	DD	DW
Flux lm:	1000	925	1000	925	1000	1555	1000	925

**Table 3:** Types of control schemes

System design for this introduced application depends on many factors, including the light source capabilities, thermal design and the target lighting application. It is possible, however, to find a system specification with concatenated aging structure for a specified application based on the luminous flux of each state. Table 4 shows a system, where the two states are forecasted to be operated in a 85% to 15% duty cycle. Based on this a control scheme was found that dims the channels in a way, so that the lumen depreciation based on TM-21-11: Projecting Long Term Lumen Maintenance of LED Packages will be aligned using a set of LM-80 data.

**Luminous intensity separation**

Equations 2 describe the mixing of two intensity distributions for a resulting system output ( $D_D$  and  $D_W$  being the desired output) and are the residual arrays in each case from the specified values.

$$\begin{aligned} R_A \cdot D_{A1} + R_B \cdot D_{B1} &= D_D - \epsilon_D \\ R_A \cdot D_{A2} + R_B \cdot D_{B2} &= D_W - \epsilon_W \end{aligned} \quad (2)$$

With a given control scheme defined, the required intensity distributions are calculated as:

$$R_A = \frac{(D_W - \frac{D_{B2}}{D_{B1}} \cdot D_D)}{(D_{A2} - \frac{D_{B2}}{D_{B1}} \cdot D_{A1})} \quad (3)$$

$$R_B = D_W - (D_{A2} \cdot R_A) \quad (4)$$

After these calculations, an iteration has to be performed that restores the specified intensity distributions as shown in EQ5. This way the residual can be expressed. Whichever control scheme was chosen, the variable dimming proportion could be set to a value, where:

$$\sum \epsilon_D + \epsilon_W \xrightarrow{appr.} 0 \quad (5)$$

Figure 3 shows the result for two given desired intensity distribution using the specified system introduced in table 4.

**Conclusions**

It was shown in this paper that in many cases, having a stationary light intensity distribution over the lifetime of an outdoor roadway lighting luminaire, may result in poor uniformity of luminance (both overall- and longitudinal uniformity) by certain environmental conditions, based on the calculations of European Standard EN 13201. In some cases, the distortion of the luminance distribution perceived by a standard observer may even cause disability glare.

Therefore a method was described, that provides controllability of the intensity distribution in order to satisfy lighting requirements with changing optical properties of the environment, thus providing better perceptibility of obstructions, reducing glare and elevating safety for all roadway users. The introduced algorithm aims aligned lumen depreciation of the channels of specifically generated arbitrary intensity distributions that are designed to support the special requirements demanded by this separation. ■

**Table 4:**  
Control scheme for aligned aging characteristics

Part	State D	State W
D <sub>A</sub>	80%	61%
D <sub>B</sub>	70%	90%
Duty cycle:	85%	15%
Flux [lm]	1000	925
Flux A [lm]:	533	374
Flux B [lm]:	467	551

**Figure 3:**  
The desired light intensity distributions for a target application: DD (top-left) and DW (top-right) and the restored distributions of the separation (bottom row)

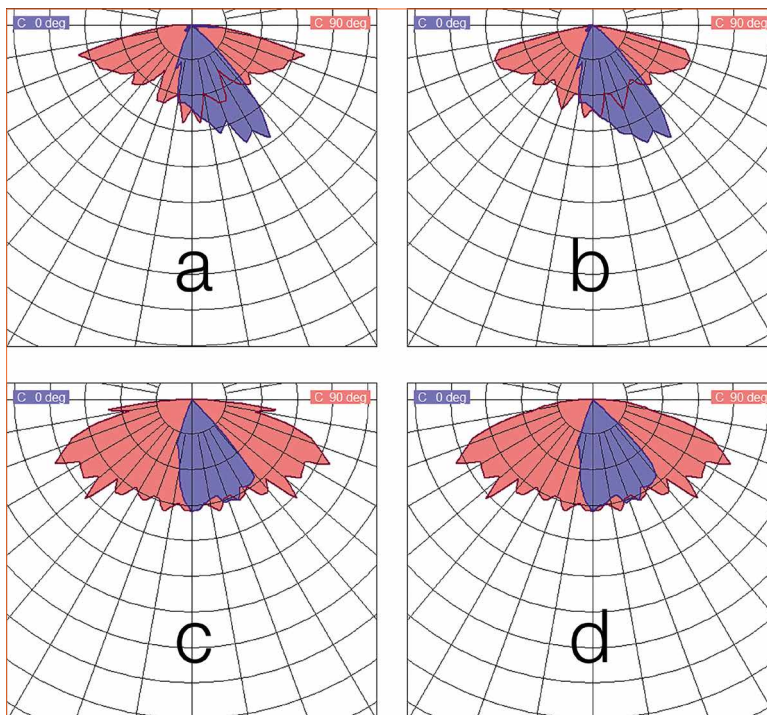

**References:**

- [1] Lighting for driving, Peter R. Boyce, CRC Press, 2008, ISBN-13:978-0-849-8529-2
- [2] The outdoor lighting guide, The Institution of Lighting Engineers, Taylor & Francis, 2005, ISBN 978-0-4153-7007-3
- [3] European Standard EN 13201-3 Road lighting - Part 3: Calculation of performance
- [4] A genetic algorithm tutorial, Darrell Whitley, Statistics and Computing, 65-85, 1994

# Exclusive. Extraordinary. FREE.

UPDATED VERSION 1.1 AVAILABLE  
DESIGN YOUR LUMINAIRE NOW!  
<http://www1.FutureLightingSolutions.com/LSC>

## Over 20,000 Lighting Simulations Completed with Future Lighting Solutions' Lighting System Creator Design Tool

The Lighting System Creator is a free online design tool offered by Future Lighting Solutions which enables the user to seamlessly create an entire lighting system. Powered by a proprietary algorithm leveraging light source LM-80 data, the LSC automatically provides appropriate and application specific light sources based on value engineering principles, determines the optimal forward current and temperature to meet target flux, efficacy and L70 lumen maintenance values.

- The LSC will optimize the temperature and current to minimize the LED count and suggest the most cost effective approach to meet target specifications using LEDs, COBs, and even modules and integrated light engines.
- In cases where the user wishes to consider one specific type of light-source for the application, the user can now specifically select their preference versus being presented with all possible technical solutions.
- The LSC now also includes light sources that do not yet have an available LM-80 report. This now enables users to consider recently released products for design consideration in to their fixtures.
- The tool also includes an automatic offset that incorporates the efficiency impact of the integrated driver and/or integrated optic for modules and light engines when applicable.

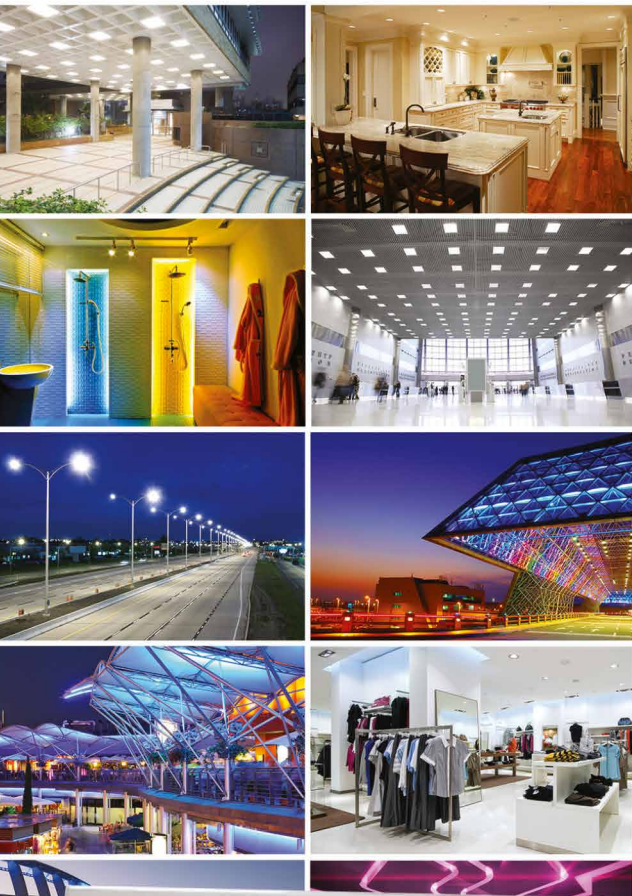

**LIGHTFAIR International 2017**  
May 9<sup>th</sup> – 11<sup>th</sup>, 2017  
Booth #: 3515  
Pennsylvania Convention Center

**FUTURE**  
Lighting Solutions  
Making LED Lighting Solutions Simple™

[www.FutureLightingSolutions.com](http://www.FutureLightingSolutions.com)

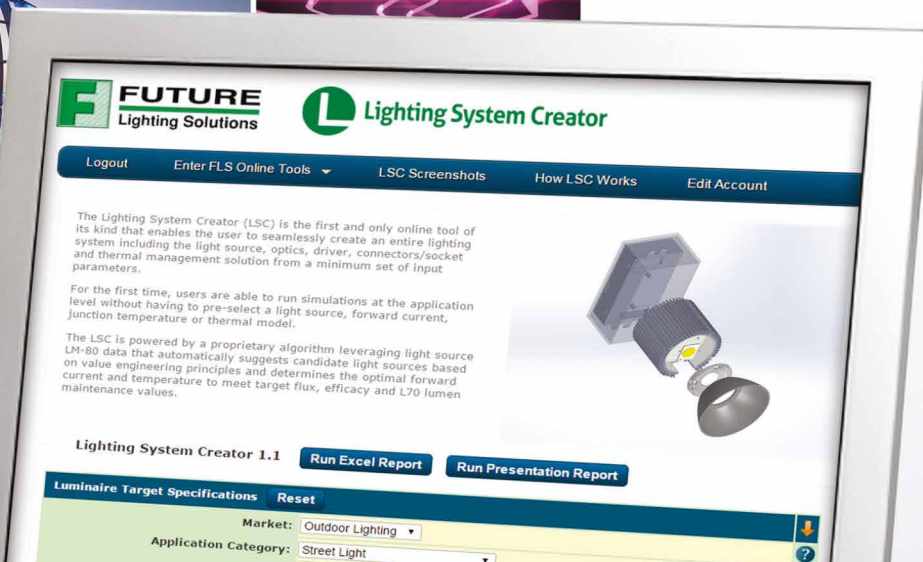



# Lead Halide Perovskite Nanocrystals - A New Promise for Light Emitting Devices

Perovskites structured materials have attracted scientific and technological interest in the last four years. Recent studies have shown that these materials could deliver high photoluminescence efficiency at any desired wavelength in the visible spectrum. Mirko Prato and Francesco Di Stasio, Technologist and Marie Curie Fellow of the Institute of Photonic Sciences at the Istituto Italiano di Tecnologia focus on the application in single color LEDs (red, green and blue) and white emitting color-converting layers. They discuss what limits their application in everyday technology like toxicity and limited functional stability.

Perovskites structured materials have attracted great interest for optoelectronics applications in the last four years. Mostly, this is thanks to the promising properties of such materials combined with low cost and solution based processing, which greatly contribute to their high potential for photovoltaic and light-emitting devices (LEDs). Recent studies have shown that these materials could also be obtained as colloidal nanocrystals exhibiting very high photoluminescence efficiency and with the possibility to emit at any desired wavelength in the visible spectrum by tuning their chemical composition and/or by controlling their size and shape. Even though research on perovskite nanocrystals is still at the starting stage, they are expected to have a significant impact in the development of novel lighting devices in the near future thanks to their facile synthesis

compared to other semiconductor nanocrystals. Here, we discuss the latest findings on perovskite nanocrystals light emitting devices. In particular, we will focus on their application in single color LEDs (red, green and blue) and white emitting color converting layers. Furthermore, we will discuss what limits their application in everyday technology, such as toxicity (caused by the presence of lead in their structure and the use of organic solvent for processing), and limited functional stability.

## Introduction: The Rise of Lead Halide Perovskites

Lead halide perovskites are quite an old material, already having been synthesized for the first time in 1893[1] and fully characterized from a structural point of view in the late 1950s [2].

The typical perovskite crystal structure is reported in figure 1. Lead halide perovskites have the chemical formula  $APbX_3$ , where A is a monovalent cation and X is a halide ion (either Cl<sup>-</sup>, Br<sup>-</sup> or I<sup>-</sup>). As reported in figure 2, Pb and X ions arrange forming sharing-corners octahedra and the

**Figure 1:**  
Top panel: Crystal structure of cubic lead halide perovskites with the generic chemical formula  $APbX_3$

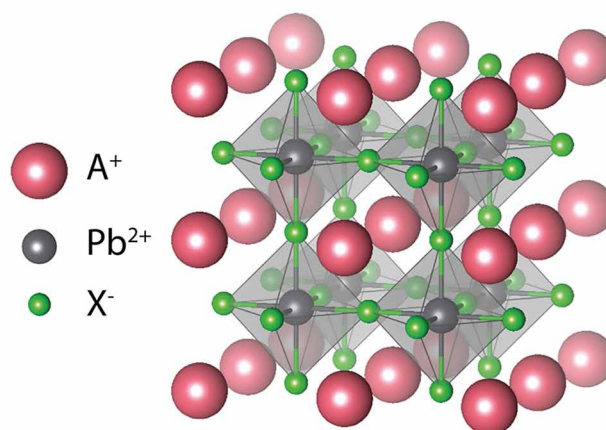

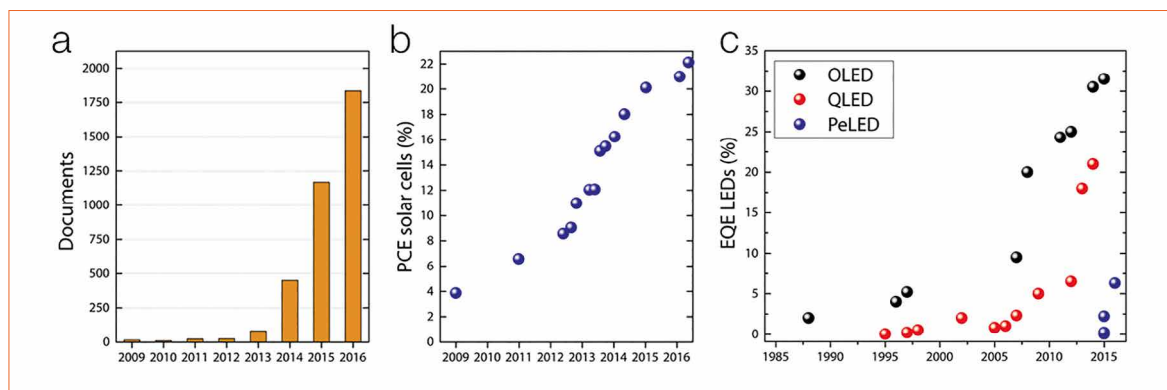

**Figures 2a-c:** Number of scientific publications dealing with solar cells based on perovskite materials in the last 7 years (Source: <http://www.scopus.com>); rapid increase in perovskite solar cell power conversion efficiency in the same period of time (Source: NREL efficiency chart [4]); comparison of LED external quantum efficiencies in OLED, QLED and perovskite-based LED (PeLED)

monovalent cation fills the space in between four  $(\text{PbX}_6)^{4-}$  octahedra. The monovalent cation is typically either an alkali metal (cesium,  $\text{Cs}^+$ ) or a small organic molecule as methylammonium (MA,  $\text{CH}_3\text{NH}_3^+$ ) or formamidinium (FA,  $\text{CH}(\text{NH}_2)_2^+$ ).

Despite their age, these materials only came to the interest of the optoelectronics community quite recently. Indeed, it was 2009 when, for the first time, Kojima et al. introduced  $\text{CH}_3\text{NH}_3\text{PbI}_3$  (having a direct bandgap of 1.55 eV, which makes this material a good light absorber over the whole visible solar emission spectrum) as sensitizers for solar cells, measuring a power-conversion efficiency of 3.8% [3]. Starting from this germinal work, an increasing number of papers appeared in recent years, reaching the impressive number of 1834 papers dealing with perovskite-based solar cells in 2016 (more than 5 papers a day!); researchers quickly identified challenges that needed to be addressed for these materials to be technologically successful, showing continuous improvements in device architectures and conversion efficiencies, that reached the value of 22.1% [4] in 2016. The results obtained for high-efficiency photovoltaics suggest that lead halide perovskites are excellent semiconductors for optoelectronic devices in general: an efficient solar cell material should also be a good light emitter according to the detailed balance in the Shockley–Queisser formulation [5], where all recombination should ultimately be radiative. Indeed, previous works have shown that perovskites possess strong

photoluminescence, making them potential candidates for use not only in solar cells but in light-emitting devices, too [6]. In particular, perovskite nanocrystals (NCs) obtained by colloidal synthesis can exhibit very high photoluminescence quantum efficiency, coupled with narrow emission linewidths and color tuning over the entire visible spectrum.

In this document, we will briefly summarize the latest finding on the emerging field of perovskite nanocrystals. Firstly, we will give an overview of the typical synthesis protocols for these NCs, focusing on the optical properties from a solution. We will also comment on the possibility of tuning the emission color, either by chemical composition or by shape engineering. We will then move to discuss the main results obtained with these NCs in monochromatic LEDs as well as phosphors in white color layers. We will also discuss the issues that are limiting to the implementation of these materials in commercial LED systems.

### Colloidal Synthesis of Lead Halide Perovskite NCs

The first solution-based synthesis of colloidal  $\text{MAPbBr}_3$  NCs was reported by Pérez-Prieto and colleagues in 2014 [7]. After this seminal work, researchers around the world have reported several synthesis protocols for perovskite NCs. It is out of the scope of this document to enter into the details of all the different methods, for which we refer the interested readers to the recent review by A. Rogach and coworkers [8].

It is, however, helpful to underline the common points between those methodologies. Indeed, independently on the choice of the monovalent cation (either MA or FA for hybrid organic-inorganic  $\text{MAPbX}_3$  perovskites or Cs for fully inorganic  $\text{CsPbX}_3$  NCs), most of the protocols rely on the use of long chain organic molecules (amines and/or acids), used to provide a self-termination of the crystallization, leading to the formation of discrete nanoparticles in solution. These solutions (typically in organic solvents) have been shown to be stable over several weeks/months, provided that no polar substances (like water and moisture, for instance) come in contact with the NCs themselves. Due to the ionic character of these perovskites, in fact, the NCs could easily deteriorate if the proper mixture of solvents is not used. This environmental instability is more pronounced for hybrid perovskites, e.g.  $\text{MAPbI}_3$  could dissociate into  $\text{PbI}_2$  and MAI, the latter of which is volatile [9]. A fully inorganic structure without a volatile organic component is therefore highly desired, especially in view of a possible use of these materials in commercial devices.

The preparation methods for fully inorganic  $\text{CsPbX}_3$  NCs can be divided into two classes: the so called “hot injection” and “room temperature recrystallization”. In the “hot injection” approach,  $\text{PbX}_2$  powder is dissolved in a mixture of organic solvent and surfactants. After that, the preheated Cs precursor is injected into the  $\text{PbX}_2$  solution at a specific temperature (in the 130–200°C range) and then,

NCs form. Their growth is usually arrested by abruptly lowering the reaction temperature with an ice-bath. Even if this approach usually results in NCs of higher quality in terms of crystallinity and size and shape dispersion, the use of high temperatures and controlled reaction atmospheres as well as the needed abrupt temperature change could potentially limit its application for large scale production. On the other side, “room temperature recrystallization” methods could face the requirements of upscaling. In this approach, which can be briefly described as transferring inorganic ions from good into very poor solvents,  $\text{Pb}^{2+}$ ,  $\text{Cs}^+$  and  $\text{X}^-$  sources powders are dissolved completely in a specific solvent together with surfactants. Secondly, a small amount of the above solution is added into a bad solvent. After transfer, the enormous drop in solubility produces a highly supersaturated state immediately, which induces a rapid recrystallization. Surfactants help to control the size and disperse them in various nonpolar solvents. So obtained NCs exhibit comparable optical properties to that of NCs synthesized at high temperatures [10].

The main distinctive character of the optical properties of these NCs could be summarized as follows:

Dependence of the emission wavelength on the halogen (X = Cl, Br or I):

Independently on the choice of the monovalent cation and of the preparation protocol, lead halide perovskite NCs show an interesting dependence of the emission wavelength on the used halide ion. If the size of the NCs is large enough to avoid quantum confinement effects, Cl-based NCs emit in the blue-violet region, Br-based NCs in the green region and I-based NCs in the red region of the visible spectrum. Therefore, using the very same preparation method, and changing only the chemical nature of the halogen, it is possible

to obtain the fundamental emitters of the RGB color model.

Narrow emission line-widths:

As in the case of other semiconductor quantum dots, lead halide perovskite NCs are also characterized by narrow photoluminescence line-widths. Typical full width at half maximum values are in the order of 0.1 eV, corresponding to 12-15 nm in the blue-violet, approximately 20 nm in the green and 35 nm in the red region of the visible spectrum [11, 12].

High PL QY:

Furthermore, even without any surface shelling, the lead halide perovskite NCs show quite high photoluminescence quantum yield values. This is true especially for Br- and I-based NCs, for which PLQY of almost 100% [13] and 60-70% [14], respectively, have been reported. Importantly, such high efficiency values are partially retained in films where efficiencies above 30% are observed [15].

On the other hand, Cl-based NCs are typically less luminescent, and PLQY of maximum 10% have been reported.

## Tuning of the Optical Properties

A useful property of lead halide perovskite is that mixed-halide compositions are possible. This implies that, by a careful balance of the used halogens, any desired emission wavelength in the 400 – 700 nm range could be targeted and obtained. There are two ways to obtain such a result. The first is to run the colloidal synthesis by combining appropriate ratios of halogen precursors (e.g.  $\text{PbX}_2$  salts), as done for instance by the group of M. Kovalenko [12]. Alternatively, it is possible to make use of a peculiar property of perovskites in general, i.e. the mobility of anions (halides, in the present case) in the crystal lattice. In this way, by exposing a solution of  $\text{CsPbBr}_3$  NCs to an excess of other halide ions (either

Cl or I), we demonstrated that anion exchange reactions occur and Br ions could be replaced partially or completely in the NCs, resulting in a blue shift (adding Cl) or red shift (adding I) of the PL peak. The optical properties (PL linewidth and QY) of the NCs obtained by anion exchange are in line with those of the NCs obtained by direct synthesis [11].

Another interesting venue to control perovskite nanocrystals emission is a typical approach for semiconductor quantum dots, i.e. quantum confinement. By changing the synthesis conditions (such as reaction temperature, acidity of the reaction medium and/or chain length of the organic molecules used as surfactants), researchers have been able to tune the size of the NCs down to the quantum confinement regime [16-19]; in this condition, the band-gap of the lead halide perovskite could be “opened” in a control manner and, accordingly, the PL peak could be blue-shifted. This procedure could be particularly helpful to obtain bright blue emitters based on lead bromide perovskites since, as we discussed before, PL QY values in the blue-violet region of the visible spectrum are typically lower than in the rest of the spectrum.

## LEDs for Display Application

LEDs based on perovskites films are still outperforming their NCs counterpart. As an example, in 2015, hybrid organic-inorganic perovskites were used to demonstrate green emitting LEDs with a current efficiency of 42.9 Cd/A [20]. Nonetheless, inorganic ( $\text{CsPbBr}_3$ ) perovskite nanocrystals based LEDs showed an astonishing improvement in performance since their synthesis has been reported at the beginning of 2015. In fact, the first green emitting  $\text{CsPbBr}_3$  nanocrystal LED reported a current efficiency of 0.43 Cd/A at the end of 2015 [21], and in just more than a year (end of 2016) these type of LEDs have reached 13.3 cd/A in a similar



# Lighting the World ONE LED AT A TIME

## High Power Series



**219 SERIES**



**229 SERIES**



**144 SERIES**

Tightest optical control  
Superior reliability  
Low thermal droop  
Industry standard footprint

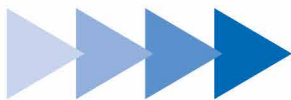

**Request Your FREE Samples Now!**

[www.bit.ly/FLSNichiaSamples](http://www.bit.ly/FLSNichiaSamples)

Available in Europe and the Americas

 **NICHIA**  
[www.NICHIA.com](http://www.NICHIA.com)

**LIGHTFAIR International 2017**  
May 9<sup>th</sup> – 11<sup>th</sup>, 2017  
Booth #: 3515  
Pennsylvania Convention Center

 **FUTURE**  
**Lighting Solutions**  
*Making LED Lighting Solutions Simple™*  
[www.FutureLightingSolutions.com](http://www.FutureLightingSolutions.com)

**Table 1:**  
Overview of representative results on inorganic and hybrid halide perovskite nanocrystals LEDs: electroluminescence peak emission (nm), turn-on voltage (V), maximum external quantum efficiency (EQE), maximum current efficiency (Cd/A), maximum luminance (Cd/m<sup>2</sup>), reference and date of publication

Material	Emission Wavelength [nm]	Turn-On Voltage [V]	Max EQE [%]	Max. Current Efficiency [Cd/A]	Max. Luminous Efficacy [lm/W]	Max. Luminance [Cd/m <sup>2</sup> ]	Ref.	Date
CsPbBr <sub>3</sub>	516	4.2	0.12	0.43	0.18	946	[21]	Oct-15
CsPb(Br/I) <sub>3</sub>	586	4.6	0.09	0.08	0.06	528	[21]	Oct-15
CsPb(Br/Cl) <sub>3</sub>	455	5.1	0.07	0.14	0.07	742	[21]	Oct-15
CsPbBr <sub>3</sub>	516	3.5	0.06	0.19	x	1377	[25]	Jan-16
CsPbBr <sub>3</sub>	523	2.8	0.19	x	x	206	[23]	Feb-16
CsPbI <sub>3</sub>	698	2.2	5.7	x	x	2335	[23]	Feb-16
CsPbBr <sub>1.5</sub> Cl <sub>1.5</sub>	480	3.5	0.0074	x	x	8.7	[23]	Feb-16
CsPbBr <sub>3</sub>	527	4.6	2.21	8.98	3.4	3853	[26]	Apr-16
CsPbBr <sub>3</sub>	512	3.4	6.27	13.3	5.24	15185	[22]	Oct-16
MAPbBr <sub>3</sub>	521	2.9	1.1	4.5	3.5	2503	[27]	Dec-15
FAPbBr <sub>3</sub>	533	3	x	6.4	5.6	2714	[24]	Nov-16

spectral range [22] (see Table 1). Performance is improving very rapidly thanks to the “know-how” developed in the last 20 years on the fabrication of LEDs using solution processed materials. In fact, most of the fabrication techniques used in organic (OLEDs) or II-VI and III-V semiconductor quantum-dot LEDs (QLEDs) are completely transferrable and nowadays a plethora of different materials that can be used as electrodes or charge transport layers are available, thus facilitating device optimization. Despite the rapid improvement in efficiency and emitted luminance, most of the results reported in literature are limited to the green spectral region (500-550 nm) with only two articles reporting red and blue emitting perovskite nanocrystal LEDs [21, 23]. Red emitting perovskite nanocrystals LED have shown a maximum luminance of 2335 Cd/m<sup>2</sup> (current efficiency is not reported in this case). On the other hand, blue emitting perovskite nanocrystals LEDs are still lagging behind in terms of efficiency and maximum luminance.

Hybrid-inorganic-organic perovskite nanocrystals based on methylammonium (MAPbBr<sub>3</sub>) have been employed as well. This type of LED has shown a current efficiency of 4.5 Cd/A in 2015. Up until now MAPbBr<sub>3</sub> nanocrystals have seen a

limited research focus for light-emission applications compared to fully inorganic perovskite ones. This is because replacing MA with inorganic Cs offers the perovskite extra thermal stability up to its melting point ( $\approx 500$  °C) and promise longer device operational lifetime. In fact, a major issue of perovskite nanocrystals LEDs is their stability and overall operational lifetime. This has been studied marginally compared to the work done for perovskite solar cells and much more work is necessary to shed light on the degradation processes taking place during LED operation, air exposure and their storage (the so called “shelf-life”). For example, the use of mixed halides for color tuning has already been reported to cause unstable emission color after only few seconds of operation [23].

Despite the great improvement in efficiency and luminance for green-emitting LEDs observed in just over one year, much effort is still needed to understand the nanocrystals degradation processes, stabilize their color, fabricate efficient blue and red LEDs and optimize the device architecture. All these represent great challenges while chemists around the world are constantly synthesizing novel perovskite nanocrystals (very recently, for example formamidinium based

perovskite green-emitting LEDs have been demonstrated with a current efficiency of 6.4 cd/A [24]). The constant search for new perovskite nanocrystals structures and compositions is motivated by the presence of lead in the crystal. Toxicity of lead based perovskite remain an important limiting factor for commercial application and the hope is that knowledge achieved on the fabrication of LEDs using fully inorganic or hybrid lead perovskite nanocrystals can transferred to their non-toxic counterparts be in the future.

### Perovskites Nanocrystals as Phosphors and in Light-Converting Layers

Another venue for application of perovskite nanocrystals is their use as phosphors. More conventional II-VI and III-V semiconductor quantum-dots have already seen successful application in this field in display applications, for example Samsung recently commercialized their first ultra-high definition TV based on Quantum dots. Such technology in display removes the reduced vision angle typical of LCD displays and allows enhanced contrast. Similarly, perovskite nanocrystals have been used for the fabrication of color converting layers but for the generation of white light, mainly thanks to the ease of tuning their color. Phosphor-based

# Illumination - Innovation - Imagination



## 1% Xitanium Indoor Linear and Point Source Drivers

The Philips Advance Xitanium range of programmable LED drivers are perfectly suited for Linear & Downlight fittings in commercial applications. These models are compatible with standard 0-10V dimming systems to deliver reliably smooth dimming performance down to a minimum of 1%.



### Linear LED Driver with 1% Dimming + SimpleSet

- 20W/40W/54W/75W Linear Mount
- 120-277V Main Input
- Class 2 Output
- 0-10V Dimming
- 1% Minimum Dimming Level
- Programmable Dimming Options
- UL/CSA/ETL
- Class P
- Compatibility with Fortimo Linear Modules
- 5 Year Warranty

### Applications

Indoor Linear, Office and Retail Lighting

### Point Source LED Drivers with 1% Dimming + SimpleSet

- 25W/36W/50W J Box Mount (Bottom Entry)
- 25W/36W/50W Surface Mount (Side Entry)
- 120-277V Main Input
- Class 2 Output
- 0-10V Dimming
- 1% Minimum Dimming Level
- Programmable Dimming Options
- UL/SREC
- UL/CSA/ETL
- Class P
- Compatibility with Fortimo Modules
- 5 Year Warranty

### Applications

Indoor Downlights, Wall Sconce, Ceiling, Retail and Hospitality Lighting

For the latest information on Philips products contact your local FLS sales representative.

This information is accurate at the time of writing. Neither Philips nor its agents assume any liability for inaccuracies or losses incurred by use or misuse of this information. Check manufacturer's website for the most recent information.

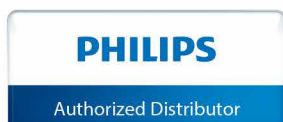

**LIGHTFAIR International 2017**  
May 9<sup>th</sup> – 11<sup>th</sup>, 2017  
Booth #: 3515  
Pennsylvania Convention Center

**FUTURE**  
Lighting Solutions  
*Making LED Lighting Solutions Simple™*  
[www.FutureLightingSolutions.com](http://www.FutureLightingSolutions.com)



**Figure 3:** Solutions of lead halide perovskite NCs of different halide composition under UV light illumination. By changing the halogen X in the material, it is possible to obtain bright emitters in the red – violet spectral range (top). Corresponding PL profiles (bottom)

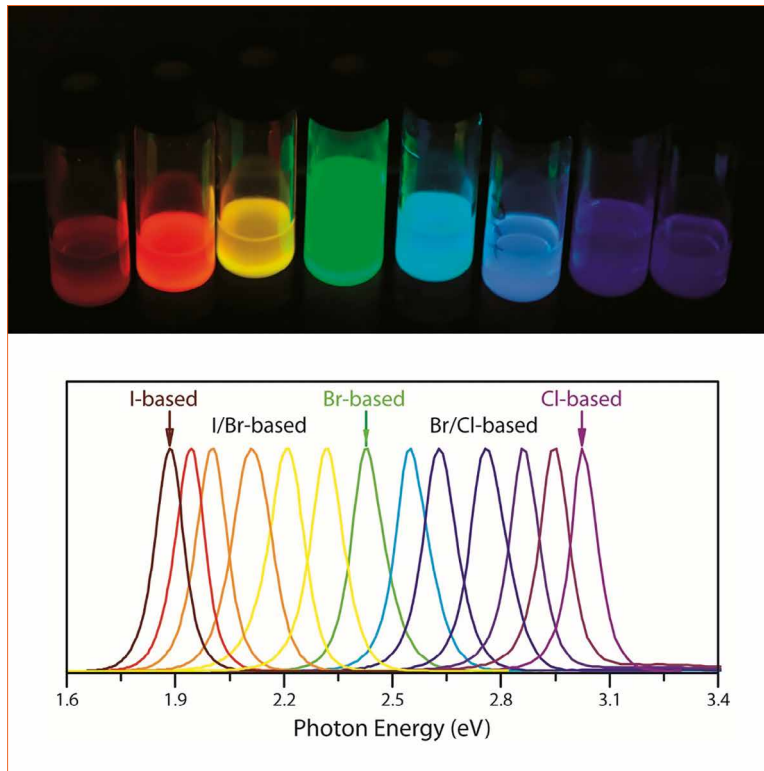

solid-state white LEDs provide a much higher efficiency alternative to incandescent and fluorescent lighting. In particular, few relevant examples of perovskite white emitting layers are present in the literature, employing either  $\text{CsPbX}_3$  (where X is either Br, I or Cl) inorganic nanocrystals [28, 29], hybrid perovskite nanocrystals, or hybrid methyl and octylammonium meso- to nanoscale crystals [30]. In all cases, researchers have taken advantage of the color tailoring of perovskite by changing the type of halide in their structure or the nanocrystal size/shape. In these applications, perovskites nanocrystals have demonstrated the capability of obtaining color-rendering index above 80 with

color temperature in the 5000-6000 K range, similar to currently commercially available white LEDs.

Another interesting application of perovskite nanocrystals as phosphors is in the field of telecommunication. Thanks to their relatively fast photoluminescence lifetime (of less than 10 ns)  $\text{CsPbBr}_3$  nanocrystals have been successfully employed as phosphors in a visible light communication system (VSL) [31]. This technology promises to solve the current limitations in data and wireless communication present in conventional IR-based networks. As such, VSL requires fast emitters with a large modulation bandwidth. In the case of the light converter proposed (employing both

perovskite nanocrystals and conventional phosphors), the system shows a bandwidth of 491.4 MHz, a value significantly higher than conventional nitride-based phosphors (~12.4 MHz), organic materials (40–200 MHz) or YAG-based phosphors (3–12 MHz), demonstrating once again the potential of perovskite nanocrystals in yet another field of photonics.

## Conclusions

In spite of their intriguing properties, the use of lead halide perovskite NCs in commercial devices is, however, still far away. In a matter of only 1 year the performance of LEDs based on perovskite nanocrystals has seen a tremendous improvement through better material engineering, further motivating research in this field to achieve higher efficiency. Nevertheless, it is important to remember that operational lifetime of these devices is still very limited and a full understanding of degradation processes has still to come. The applicability of perovskite is not limited to LED but as phosphors as well, yet conventional quantum dots based on II-VI and III-V semiconductor have already overtaken this commercial field. Other major concerns are on Pb toxicity and on the intrinsic instability of the perovskite structure. The future of perovskites seems very bright but many challenges are still ahead to exploit this class of materials in real life applications outside a research laboratory. ■

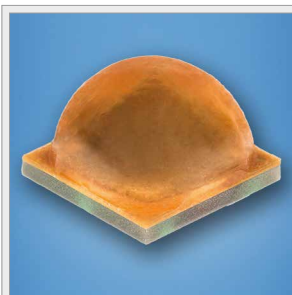

### Cree's New XLamp® XHP50.2 LED Delivers the Highest Lumen Density in Its Class

Cree's XLamp XHP50.2 LED delivers up to 7% more lumens and 10% higher LPW than the first gen XHP50 LED. The XHP50.2 can produce more than 2,500 lumens from its 6 mm light emitting surface to reduce size, cost and enable innovative solutions for applications from spot to street lighting. LM-80 data is available to reduce the time for ENERGY STAR® and DesignLights Consortium® qualifications.

[www.cree.com/xlamp/xhp50\\_2](http://www.cree.com/xlamp/xhp50_2)

**CREE** 

**References:**

- [1] Wells, H.L., Über die Cäsium- und Kalium-Bleihalogenide. *Zeitschrift für anorganische Chemie*, 1893. 3(1): p. 195-210
- [2] Moller, C.K., Crystal Structure and Photoconductivity of Caesium Plumbobalides. *Nature*, 1958. 182(4647): p. 1436-1436
- [3] Kojima, A., et al., Organometal Halide Perovskites as Visible-Light Sensitizers for Photovoltaic Cells. *Journal of the American Chemical Society*, 2009. 131(17): p. 6050-6051
- [4] NREL Efficiency Chart. Available from: [http://www.nrel.gov/ncpv/images/efficiency\\_chart.jpg](http://www.nrel.gov/ncpv/images/efficiency_chart.jpg)
- [5] Shockley, W. and H.J. Queisser, Detailed Balance Limit of Efficiency of p-n Junction Solar Cells. *Journal of Applied Physics*, 1961. 32(3): p. 510-519
- [6] Tan, Z.-K., et al., Bright light-emitting diodes based on organometal halide perovskite. *Nat Nano*, 2014. 9(9): p. 687-692
- [7] Schmidt, L.C., et al., Nontemplate Synthesis of CH<sub>3</sub>NH<sub>3</sub>PbBr<sub>3</sub> Perovskite Nanoparticles. *Journal of the American Chemical Society*, 2014. 136(3): p. 850-853.
- [8] Huang, H., et al., Colloidal lead halide perovskite nanocrystals: synthesis, optical properties and applications. *NPG Asia Mater*, 2016. 8: p. e328
- [9] Nenon, D.P., et al., Structural and chemical evolution of methylammonium lead halide perovskites during thermal processing from solution. *Energy & Environmental Science*, 2016. 9(6): p. 2072-2082
- [10] Li, X., et al., All Inorganic Halide Perovskites Nanosystem: Synthesis, Structural Features, Optical Properties and Optoelectronic Applications. *Small*, 2017: p. 1603996-n/a
- [11] Akkerman, Q.A., et al., Tuning the Optical Properties of Cesium Lead Halide Perovskite Nanocrystals by Anion Exchange Reactions. *Journal of the American Chemical Society*, 2015. 137(32): p. 10276-10281
- [12] Protesescu, L., et al., Nanocrystals of Cesium Lead Halide Perovskites (CsPbX<sub>3</sub>, X = Cl, Br, and I): Novel Optoelectronic Materials Showing Bright Emission with Wide Color Gamut. *Nano Letters*, 2015. 15(6): p. 3692-3696
- [13] Gonzalez-Carrero, S., et al., The Luminescence of CH<sub>3</sub>NH<sub>3</sub>PbBr<sub>3</sub> Perovskite Nanoparticles Crests the Summit and Their Photostability under Wet Conditions is Enhanced. *Small*, 2016. 12(38): p. 5245-5250
- [14] Shamsi, J., et al., N-Methylformamide as a Source of Methylammonium Ions in the Synthesis of Lead Halide Perovskite Nanocrystals and Bulk Crystals. *ACS Energy Letters*, 2016. 1(5): p. 1042-1048
- [15] Akkerman, Q.A., et al., Strongly emissive perovskite nanocrystal inks for high-voltage solar cells. *Nature Energy*, 2016. 2: p. 16194
- [16] Sichert, J.A., et al., Quantum Size Effect in Organometal Halide Perovskite Nanoplatelets. *Nano Letters*, 2015. 15(10): p. 6521-6527
- [17] Akkerman, Q.A., et al., Solution Synthesis Approach to Colloidal Cesium Lead Halide Perovskite Nanoplatelets with Monolayer-Level Thickness Control. *Journal of the American Chemical Society*, 2016. 138(3): p. 1010-1016
- [18] Imran, M., et al., Colloidal Synthesis of Strongly Fluorescent CsPbBr<sub>3</sub> Nanowires with Width Tunable down to the Quantum Confinement Regime. *Chemistry of Materials*, 2016. 28(18): p. 6450-6454
- [19] Shamsi, J., et al., Colloidal Synthesis of Quantum Confined Single Crystal CsPbBr<sub>3</sub> Nanosheets with Lateral Size Control up to the Micrometer Range. *Journal of the American Chemical Society*, 2016. 138(23): p. 7240-7243
- [20] Cho, H., et al., Overcoming the electroluminescence efficiency limitations of perovskite light-emitting diodes. *Science*, 2015. 350(6265): p. 1222-1225
- [21] Song, J., et al., Quantum Dot Light-Emitting Diodes Based on Inorganic Perovskite Cesium Lead Halides (CsPbX<sub>3</sub>). *Advanced Materials*, 2015. 27(44): p. 7162-7167
- [22] Li, J., et al., 50-Fold EQE Improvement up to 6.27% of Solution-Processed All-Inorganic Perovskite CsPbBr<sub>3</sub> QLEDs via Surface Ligand Density Control. *Advanced Materials*, 2016: p. n/a-n/a
- [23] Li, G., et al., Highly Efficient Perovskite Nanocrystal Light-Emitting Diodes Enabled by a Universal Crosslinking Method. *Advanced Materials*, 2016. 28(18): p. 3528-3534
- [24] Perumal, A., et al., High brightness formamidinium lead bromide perovskite nanocrystal light emitting devices. *Scientific Reports*, 2016. 6: p. 36733
- [25] Zhang, X., et al., Enhancing the Brightness of Cesium Lead Halide Perovskite Nanocrystal Based Green Light-Emitting Devices through the Interface Engineering with Perfluorinated Ionomer. *Nano Letters*, 2016. 16(2): p. 1415-1420
- [26] Zhang, X., et al., All-Inorganic Perovskite Nanocrystals for High-Efficiency Light Emitting Diodes: Dual-Phase CsPbBr<sub>3</sub>-CsPb<sub>2</sub>Br<sub>5</sub> Composites. *Advanced Functional Materials*, 2016. 26(25): p. 4595-4600
- [27] Huang, H., et al., Emulsion Synthesis of Size-Tunable CH<sub>3</sub>NH<sub>3</sub>PbBr<sub>3</sub> Quantum Dots: An Alternative Route toward Efficient Light-Emitting Diodes. *ACS Applied Materials & Interfaces*, 2015. 7(51): p. 28128-28133
- [28] Song, Y.H., et al., Long-term stable stacked CsPbBr<sub>3</sub> quantum dot films for highly efficient white light generation in LEDs. *Nanoscale*, 2016. 8(47): p. 19523-19526
- [29] Palazon, F., et al., Polymer-Free Films of Inorganic Halide Perovskite Nanocrystals as UV-to-White Color-Conversion Layers in LEDs. *Chemistry of Materials*, 2016. 28(9): p. 2902-2906
- [30] Pathak, S., et al., Perovskite Crystals for Tunable White Light Emission. *Chemistry of Materials*, 2015. 27(23): p. 8066-8075
- [31] Dursun, I., et al., Perovskite Nanocrystals as a Color Converter for Visible Light Communication. *ACS Photonics*, 2016. 3(7): p. 1150-1156

# A Standardized Open Platform Is Key to the Future of Smart Lighting System Design

The LED industry's pace of evolution is more prevalent now than it has ever been. The shift from traditional standalone LED bulb lighting to fully connected digital LED systems is upon us and is transforming the industry for the better. For years, LED manufacturers have focused on driving cost down rather than focusing on improving quality, but with the advent of connected lighting, smart lighting and human-centric lighting, the focus has shifted back onto quality. Dr. Kyeongik Min, Principal Engineer in the LED business team at Samsung Electronics, explores how the LED industry can accelerate the transition from standalone lighting to fully connected lighting through a deeper understanding of current market trends.

A great number of companies like Philips and Osram have spent the last few years or so introducing connected lighting solutions, which are proving to be defining points in the evolution of LED lighting. However, for the lighting industry to continue to grow quickly within the 'smart' space, two factors are essential. First, the industry must move towards a standardized and interoperable open platform for most lighting control, and secondly, manufacturers must not overlook the cost of transitioning from traditional to digital lighting, and continue to drive efficiencies wherever possible.

The reason these factors are so important is because of smartphones. Traditionally, we have controlled lighting using switches, sensors and wall controllers that have been optimized for traditional lighting or low-level digital lighting in its early stages. However, people increasingly want to monitor the status of remote devices and control them with smartphones, anytime and anywhere.

## The Importance of Smartphone Control

The importance of smartphones and other mobile devices is undoubtedly going to grow over time. These technologies have already become the control hub for our everyday lives, enabling us to work on the go and manage our social lives through social media. Lighting has become just one other part of our lives we can now control through our mobile devices.

## How Smartphones Connect to Lighting

There are three different 'tiers' of connectivity (C1, C2 and C3), which define how smartphones can connect to lighting. The following explanations of each tier are based mainly on Bluetooth low energy (BLE) technology because of its tremendous potential and the strong reception that it has received throughout the industry.

But before getting on to the three tiers, it's important to consider that traditional legacy lighting (C0) is generally controlled by a Triac or 0-10V dimmer, which gives the control signal to the driver of the LED module in each luminaire.

Within the first tier (C1), a dedicated controller can be added to the existing driver with a BLE-equipped sensor or switch on top of the C0 to allow smartphones to directly control the lighting without the need for a cloud server. In this C1 mode, multiple smartphone controls can enable users to share lighting control with one another.

The second tier (C2) adds the cloud into the mix, which means that users can record data on their lighting, for example, which lights are on at which time, how many lights are on, how much energy they're using and more. The data that is generated can easily be monetized on a subscription basis.

And for the third and final tier (C3), a Wi-Fi/BLE bridge can be added to enable people to control their lighting through the cloud within the BLE mesh range. This type of setup enables people to confirm the status of their lighting or configure the settings at any time and from any place, remotely, or to set up the most desirable configuration in a smart space.



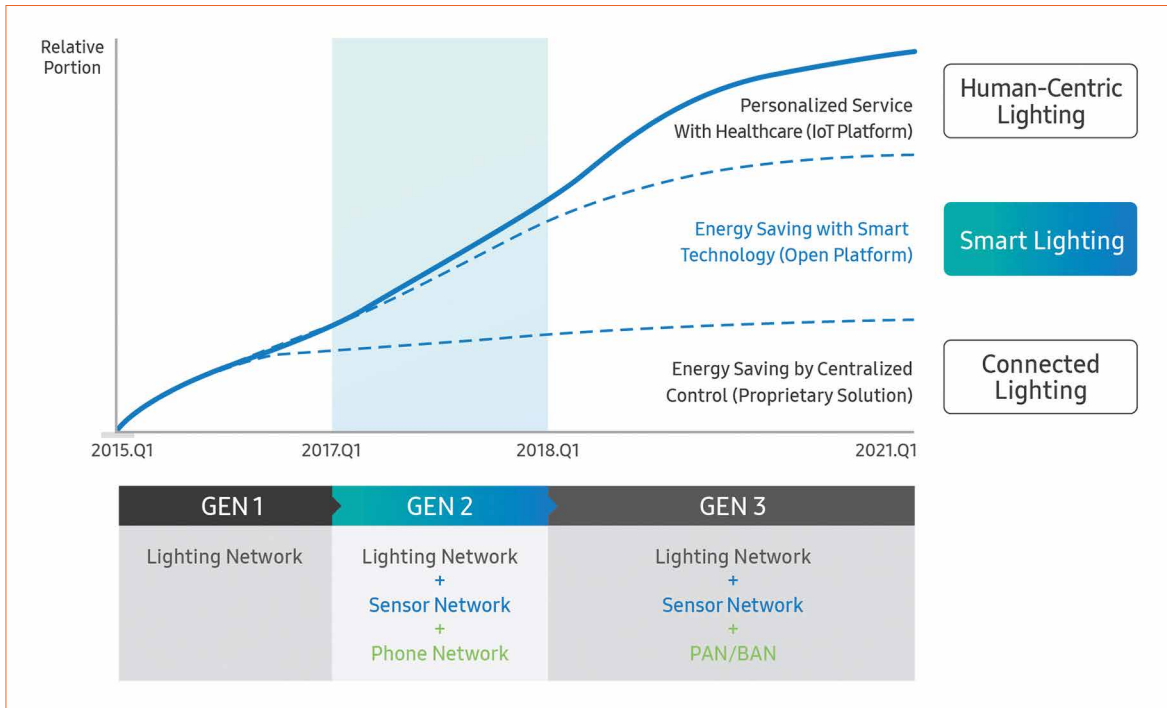

**Figure 1:**  
Three levels of  
lighting control using  
smartphones

## How Connectivity Made Smartphones the Hub of Smart Lighting

There are several reasons why each of the three tiers of smartphone connectivity is becoming more prevalent within lighting control. The first reason is the evolution of protocols, namely Bluetooth, which can now accommodate smart technology through Bluetooth low energy (BLE), as mentioned before. BLE is quite different from ZigBee, which does not support direct control with smartphones, but is at the center of much IoT activity today, especially at the end node. However, BLE can support mesh technology together with direct control for IoT applications, which is hugely important for high-density end-node applications such as smart homes.

Therefore, the standardization of the likes of DALI, ZigBee and Bluetooth is already underway because of their vital role as core connecting methodologies for lighting networks, sensor networks and wireless phone networks. Most upcoming solutions, therefore, will be based on standardized hardware and firmware so that all players in the digital lighting industry can take part in the development of viable end-to-end solutions. Towards the second half

of 2017, most new smart lighting products will be based on DALI 2.0, ZigBee 3.0 and Bluetooth 5.0.

The second reason why smartphones have been able to become control hubs for lighting is because of the improvement and prevalence of mobile networks, which have progressed from 2G to 3G and 4G, LTE, and improvements to Wi-Fi networks. These improvements ensure that smartphones can easily connect to the cloud so users can control their lighting in real time from any location. In terms of security and flexibility in the use of information services, smartphone control will be more widely developed for personalized service on demand, for example healthcare services, which will make the identification through password or biometrics secure while payment process will be much easier with high security.

## The Evolution of Smart Lighting

To understand what's next in the smart lighting industry, some historical context is needed.

The three tiers of connectivity sit within the second generation of digital lighting, which is happening over the next 12 months. The first

generation started over a decade ago, with major lighting manufacturers and control system companies developing several proprietary solutions for increasing energy savings through centralized control, based on wired or wireless connectivity. The primary purpose of these first-generation solutions has been to build a lighting network that focuses on 'connecting' light. But being the first generation of digital lighting, these solutions are inherently not scalable or sufficiently interoperable with evolving network technologies such as advanced sensor networks, next-generation phone networks, PANs (personal area networks) and BANs (body area networks).

The purpose of such second-generation solutions has naturally been to standardize communication protocols and reduce the pain of commissioning and pairing, where smartphones serve as the primary smart device. In addition, the convergence of sensor and actuator networks (SANs) has created another valuable approach to enhancing the augmented network. And as discussed before, ZigBee and Bluetooth smart technology are key solutions for driving this new generation of digital lighting.

**Figure 2:**  
The digital lighting  
transformation

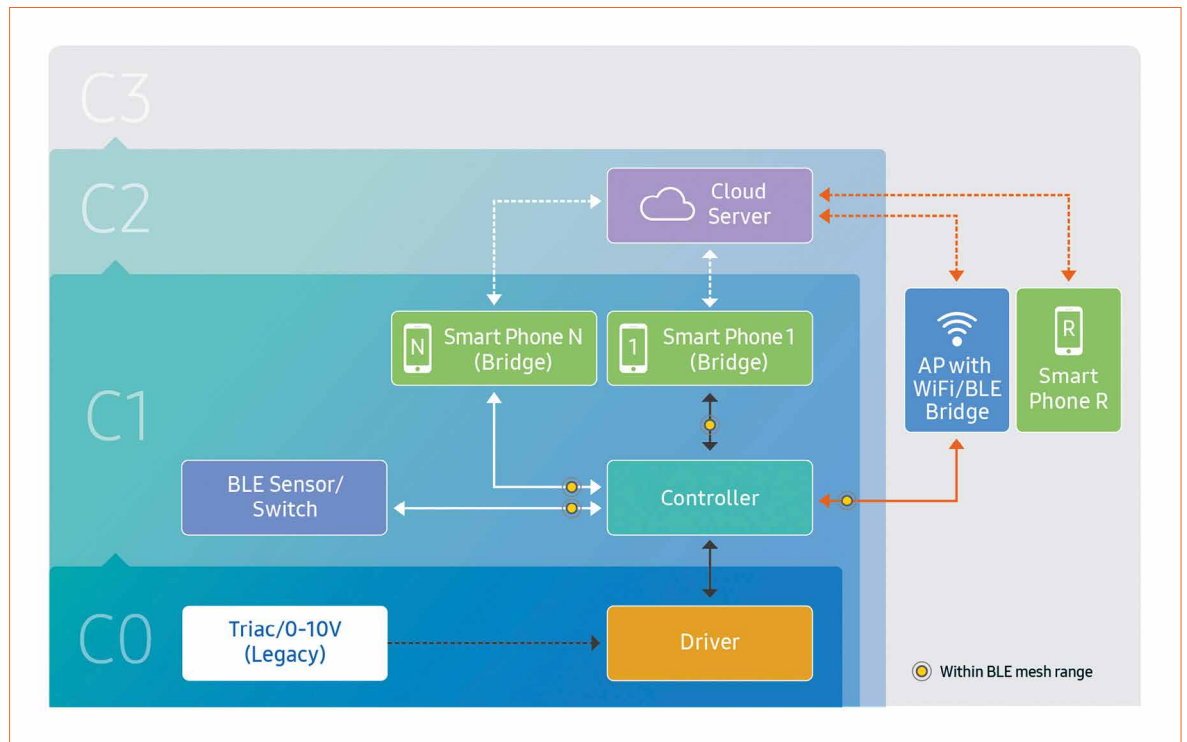

However, the ultimate goal of digital lighting is to develop a hub for the IoT (Internet of Things) that delivers additional network capabilities to PANs/BANs - the third generation of smart lighting. This trend will also lead to a shift in the smart lighting network infrastructure to embrace personalization services like healthcare, as mentioned earlier. This third generation of digital lighting will require an IP address for every node and end-to-end security architectures that can secure personal data with hardware, firmware, and software.

The essence of human-centric illumination arises from the physical and biological nature of light, and will be further enhanced when coupled with CCT-tunable and color-tunable LED technology.

### An Open Platform as Key to Success

The answer to making everything above a reality is not for LED manufacturers to build entire proprietary connected lighting solutions due to the high cost involved and subsequent high purchase cost for consumers. In other words, the benefits of connected lighting do not outweigh the costs at this time. So, to drive

the cost down, the LED industry must look towards a simple, open platform standard, upon which manufacturers can build their own smart lighting solutions. With the inevitable greater cost savings and increased opportunity for seamless integration, lighting device manufacturers can freely design LED lighting systems based on an open standard platform, and then enhance newly installed systems at their discretion. In addition, human-centric lighting should be built on the same platform, allowing for more sophisticated spectrum control and additional network devices in PANs and BANs.

Upon the open platform, manufacturers should consider trying some examples of seamless smart lighting to reduce decision-maker resistance and accelerate widespread adoption of smart lighting, as described in Figure 3. In the US, LED lighting manufacturers can install dimmable drivers for improved LED lighting or continue the use of legacy dimmers like Triac or 0-10V. With existing LED lighting systems, a BLE-enabled dimmer or BLE-enabled smart dimmer can be added to replace a Triac/0-10V dimmer. This will allow smartphones to incorporate much more flexible

use of remote control technology in a residential space. Similarly, the same technology can be applied to switches and sensors in converting most existing components to smart components, while keeping some in their legacy designs if desired. With a backward-compatible smart driver, the existing controller can be matched to a new CCT tunable driver. Furthermore, LED modules, drivers and controllers can be consolidated into a single board (or smart engine called an "S-engine"), to reduce cost to an acceptable level.

A step-by-step approach to seamless connectivity will be based on BLE-enabled solutions or the use of a BLE-ZigBee "combo" solution. By using a BLE-ZigBee combo monolithic solution (available during the second half of 2017), a simple, cost-effective, approach can be easily adopted.

Overall, the advantages for lighting manufacturers in choosing digital lighting are very compelling. To illustrate this visually, the key benefits of each step toward smart digital lighting are shown in Figure 5. Adding Bluetooth to an existing Triac/0-10V architecture requires some increase in cost, but this will



## LED test equipment from the world leader!

Whether scanning or array spectrometers, imaging photometers or colorimeters – our products and systems serve all key applications in LED/SSL and display measurement, spectroradiometry and photometry, from UV to IR.

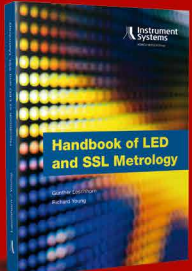

**New: „Handbook of LED and SSL Metrology“**

Available at



ISBN 978-3-86460-643-4 (Print)  
ISBN 978-3-86460-917-6 (E-Book)

**We bring quality to light.**



**Figure 3:** Seamless options for a step-by-step approach to C1 control

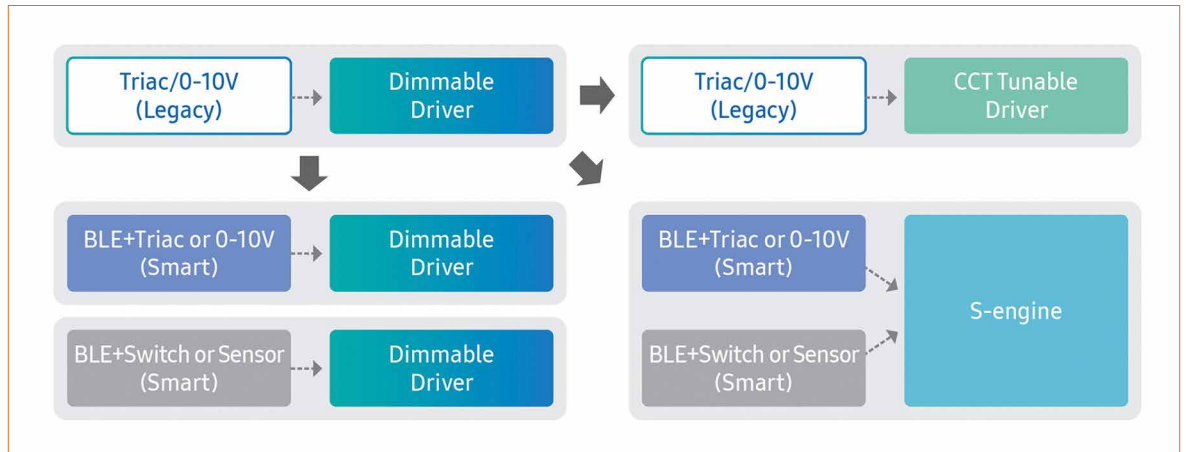

**Figure 4:** BLE-enabled solution and BLE-ZigBee combo solution in sequence



**Figure 5:** Step-by-step solutions with clear market relevance

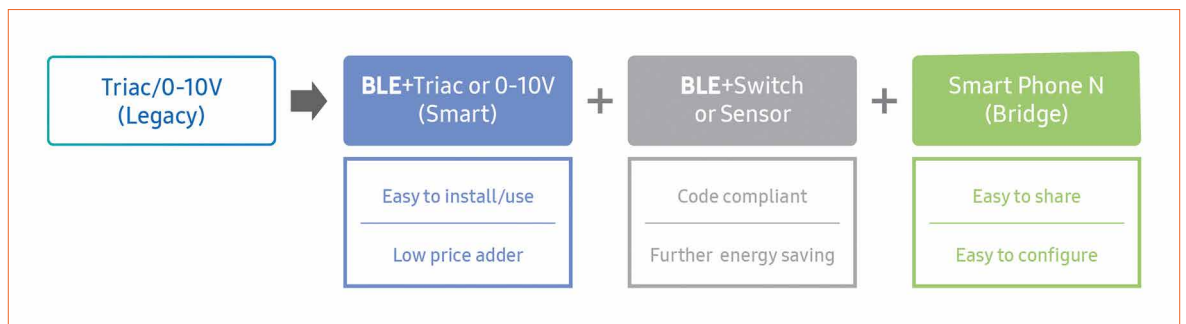

**Figure 6:** Examples for future-proof products that support different communication standards: in this case Samsung's SLM series supporting DALI2.0/ BLE5.0/ZigBee3.0

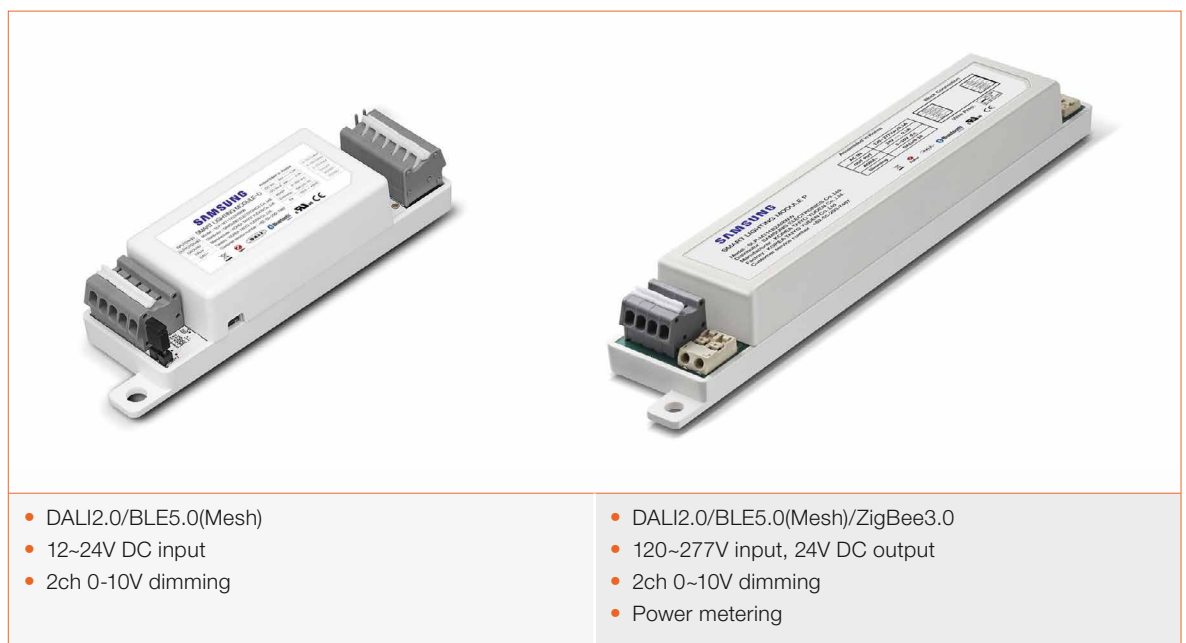

be less expensive than adding smart features to existing dimmers. There's also the opportunity to save more energy - add BLE to switches and sensors, and analyze the conditions for using smarter controls, while maintaining code compliance.

In addition, the initial investment can become even more cost-efficient by enabling multiple phone controls over any home appliance, especially useful when the controlling device is in a remote-control mode.

Beyond the above step-by-step options, new multifaceted solutions will support the latest control standards DALI 2.0, BLE 5.0 (mesh) and ZigBee 3.0. Furthermore,

2ch 0-10V dimming will be available for white color-tunable applications, and include power metering for improved energy management.

### Concluding Remarks

The driving forces for smart and human-centric lighting solutions have been carefully evaluated here, as well as how to accelerate their adoption beyond the potential hurdles that have been discussed. Combining a Bluetooth smart approach (or Bluetooth low energy) with an optimized mesh and seamless end-to-end control options will likely be the most efficient way to transition from connected to human-centric lighting, via smart lighting. To do so,

a seamless solution based on standardized DALI, ZigBee and BLE protocol currently seems to be the best and most promising approach.

Encouraging lighting manufacturers to embrace this approach is the key to a prosperous smart lighting era. The early digitalization of LED lighting will be first realized this year based on a seamless options approach. Moreover, DALI, ZigBee and Bluetooth standardization schedules prior to May 2017 will be consistent with this important shift, and the next generation of end-to-end solutions can be expected to accelerate the transition from smart to human-centric lighting in the second half of the year. ■

**InterLumi**  
The lighting trade fair can be your local partner  
**Panama**

**June 29 – July 1, 2017**  
ATLAPA Convention Center, Panama

[www.inter-lumi.com](http://www.inter-lumi.com)

Light up the path to

**The Latin American &  
Caribbean Market!**



# Looking for the Best Thermal Solution for CSP Module Designs

Chip Scale Package (CSP) LED technology is not new but while it has been used for a while in TV backlighting applications, it is relatively new to lighting applications. In many respect CSPs are a new world for lighting module manufacturers as they are smaller, usually don't have any ESD protection, have different light distribution, and, last but not least, have a smaller heat dissipation area. The latter asks for re-thinking the traditional thermal design for modules. Dr. Giles Humpston, Applications Engineer at Cambridge Nanotherm, explains in detail why CSP LEDs present a significant thermal challenge for module designers and outlines some fundamentals in calculating the thermal flow required to keep CSP LEDs cool.

CSP LEDs, the latest incarnation of flip-chip LEDs, began their life in backlighting for TVs. In these applications low and mid-power LEDs were used without any problems. As the market moves inexorably towards general lighting, the power rating of CSPs is creeping up. CSPs for general lighting fall into the 'high-power' category (over 1 W) and with devices rated up to 3 W currently available, this is causing problems.

The term 'chip scale package' is defined by the package being no more than 20% larger than the chip itself (the next step is wafer level packaging where the packaging is the same size as the chip). To achieve this, LED manufacturers strip out as many of the superfluous elements as possible. Take a standard high-power packaged LED and remove the ceramic submount and the wire bonds, directly metallize the P and N contacts and coat with a phosphor and you have a CSP LED. This method is great for LED manufacturers as it reduces both the material and manufacturing costs. It also results in a very small (often 1x1 mm) packaged

LED that can be closely packed onto PCB modules, helping to create smaller, brighter and cheaper luminaires.

As a result of these benefits the CSP market is enjoying strong growth. Industry analyst Yole Développement estimates that CSPs will make up 34% of the high-power LED market by 2020.

## Why CSPs Present Such a Thermal Challenge

However, CSPs aren't without their challenges. The small dimensions can present handling problems for pick-and-place machines. The absence of a lens means careful consideration needs to be given to beam management. But most immediate is the thermal challenge posed by the move towards ever higher-powered CSPs.

CSPs are designed to be soldered directly onto a PCB using their metallized P and N contacts. This reduces the thermal resistance between the LED die and the PCB which, viewed from one perspective, is a positive thing. However, the absence of the ceramic submount that acts as a heat spreader between the die and the

board in a traditional packaged LED means heat transfers from the die to the PCB as an intense point heat source. The thermal management challenge has, effectively, been shifted from "Level One" (the LED die packaging level) to "Level Two" (the module level). This means that module and luminaire designers have to be extremely careful to ensure CSP LEDs are provided with adequate cooling. To meet these demands Metal Clad PCBs (MCPCBs) with aluminium or copper bases are used.

To illustrate this, let us consider an example of a wire bond LED that measures 1x1 mm attached to a standard 'Level One' submount, made of aluminium nitride and measuring 3.5 mm on a side and 0.635 mm thick. In this instance the heat source is 1 mm<sup>2</sup> and assuming the thermal conductivity of the aluminium nitride is isotropic, a simple thermal model reveals the heat will spread to cover an area of approximately 5 mm<sup>2</sup>. Obviously, most of the heat remains concentrated in the central area but even so, the effect of the submount is to decrease considerably the heat flux density before it reaches the module MCPCB. With a CSP LED, the reverse applies. Again, taking a



1x1 mm device, the solder lands must be smaller than this and might only measure 0.3x0.8 mm each. This reduces the initial area available for heat transport by roughly half so less spreading has occurred by the time it reaches the cold side of the submount. This equates to a 2-fold difference in cooling ability between the CSP LED and a wire bond LED on a submount.

The price of failing to remove this heat effectively can be a reduced lifespan, poor light quality, color fluctuation and ultimately catastrophic failure of the LED.

In the absence of a submount, for CSP LEDs it is solely down to the MCPCB to conduct the heat effectively enough to keep the LED junction temperature within the manufacturer's recommended limits. This challenge becomes even harder as CSP LED dimensions shrink, power ratings increase and the module designer packs more and more CSPs into ever denser arrays – the MCPCB now really needs to work for its money.

To better understand the scale of this issue it is necessary to break this down.

## Considerations on Calculations

When calculating the thermal flow in CSP designs, the primacy of axial conduction is important: First, it's worth considering that in most CSP LED board designs, efficiency of axial thermal conduction tends to play a more important role than that of lateral thermal conduction. In this context, axial thermal conduction is z-axis, i.e. through the thickness of the MCPCB while lateral or radial thermal conduction is in-plane in the x/y-axis and occurs predominantly in the copper wiring trace of the MCPCB.

To illustrate this, consider a standard CSP LED soldered to a copper circuit layer, of around 50  $\mu\text{m}$  thick and 35 mm diameter, which in turn

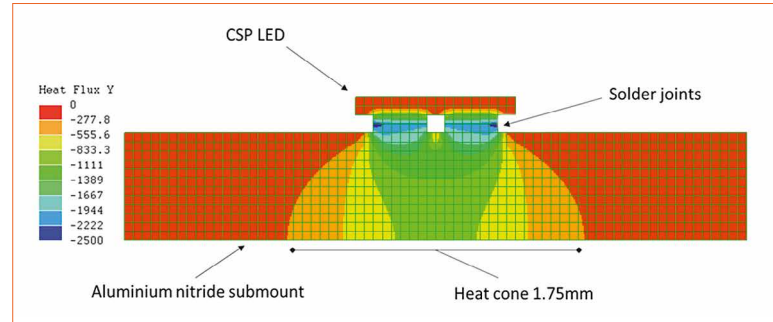

**Figure 1:** Thermal model of the heat flux emanating from a 1x1 mm CSP LED through a 0.635 mm AlN submount (170 W/mK) to a heat sink, illustrating the spreading that occurs, effectively decreasing the thermal resistance of the path

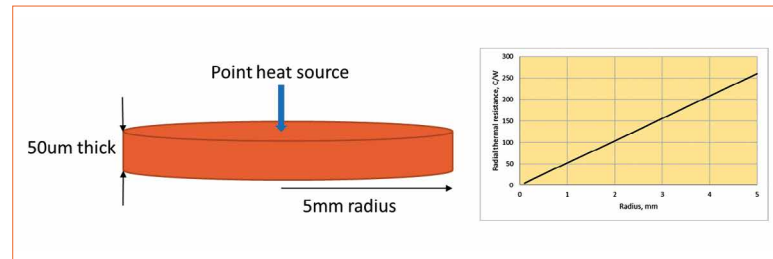

**Figure 2:** Radial heat spreading from a point source of heat in a copper disk, having dimensions representing a generous copper area of wiring trace on a MCPCB

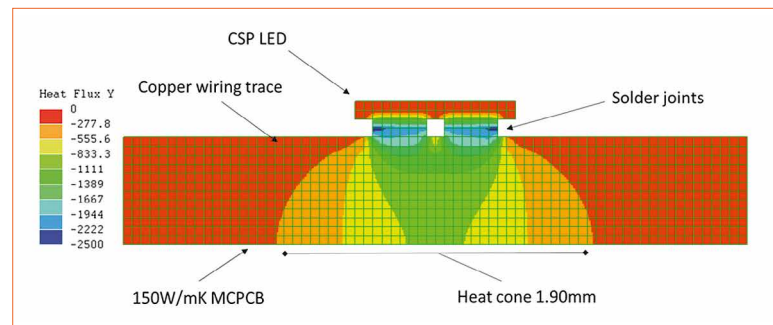

**Figure 3:** Simplified simulation of a CSP LED on a MCPCB illustrating that a 60  $\mu\text{m}$  copper wiring trace is unable to spread the heat laterally any significant distance. The close similarity of heat flow with figure 1 is to be expected when the substrate is a high performance MCPCB having an aggregate thermal conductivity in excess of 150 W/mK

sits on a dielectric, and then an aluminium heat spreader. Depending on the grade of the board the thermal conductivity of the dielectric will typically range from around 3 – 10 W/mK and between 10 and 50  $\mu\text{m}$  in thickness. This means the axial thermal impedance will range between 0.16 and 0.01  $^{\circ}\text{C}\cdot\text{cm}^2/\text{W}$ . That is, for a slab of dielectric measuring 10 mm on a side, every watt of heat flowing will not pass through instantly but result in the calculated temperature difference (0.16 - 0.01  $^{\circ}\text{C}$ ) between the two faces.

The next step is to examine the radial thermal resistance of the copper disc. Copper is an excellent conductor of heat, with a thermal conductivity of almost 400 W/mK. But at only 50  $\mu\text{m}$  thick, which is half the thickness of a human hair, its ability to transport heat along its length is severely restricted. Taking a bar of copper 1 mm wide by 50  $\mu\text{m}$  thick by 5 mm long the thermal resistance end-to-end is

over 250  $^{\circ}\text{C}/\text{W}$ . Clearly this is massive compared to the axial thermal resistance so when the copper disk is attached to a dielectric layer with very low thermal resistance, most of the heat will promptly disappear through the dielectric and down to the heat sink and none will get as far as the edge of the copper area.

This is demonstrated by expanding the previous simulation to include a 35  $\mu\text{m}$  thick layer of copper covering the whole 3.5x3.5 mm area, but keeping the hot CSP LED the same dimensions. The model shows some heat spreading taking place in the copper but the extent is limited to a 15% increase in area at the heat sink.

In practice for optimum cooling of CSP LEDs it is necessary to balance the axial and radial conductivities. If the copper area is overly reduced, too much reliance is placed on axial conduction so the thermal resistance goes up. This means

that close packing of CSP LEDs can result in thermal imbalance over the array area. Conversely, making the copper area excessively large has little benefit because of its high in-plane thermal resistance that prevents the heat spreading any significant distance.

Often it is assumed that specifying a thick layer of copper on a MCPCB will spread the heat far and wide, reducing the flux density and making it easy to remove the heat by conduction through a dielectric with mediocre thermal resistance. While this is true to a certain extent, only the very best MCPCBs have sufficiently low thermal resistance to accommodate high power CSP LEDs. With these products, increasing the thickness of the copper does not change the optimum copper area (of around 3.5 mm diameter) because the in-plane thermal conduction of even a 105  $\mu\text{m}$  (3oz) thick plane of copper on a decent quality MCPCB is still low relative to z-axis conductivity of the dielectric. There is also the constraint that the copper tracks underneath a CSP LED are required to possess a gap of around 200 $\mu\text{m}$  and this becomes progressively more difficult as the thickness of the copper increases.

In any thermal analysis of LED structures, it must be remembered that the thermal path between an LED and a heat sink is not a solid lump of homogeneous material. Usually it comprises a complex

stack of materials, such as the LED package, solder joint, circuit board, thermal interface material, heat spreader and many more. Each of these structures will have radically different dimensions, thermal conductivities and specific heat capacities, with various interface resistances between all the different layers. Of these, interface resistance is often the most critical and one of the hardest to model. The thermal resistance of a single interface can dwarf the thermal properties of the other materials in the structure and throw calculations of performance to the wind. The best technical solutions seek to minimize interface resistance between elements in the board, the most assured method of doing this being by elimination from the structure. Coatings and other layered constructions are particularly vulnerable to high interface resistance and the possibility it will change over time. While homogeneous materials are best, where an assembly of different materials is necessary, the most robust and reliable approach is to achieve bonding at the atomic level between materials. Only a limited range of coating and deposition processes function on this premise.

### About the Ideal Profile of an MCPCB Solution for CSP LEDs

So, to reiterate, high axial conduction through the MCPCB is key to a successful CSP design.

When the axial conduction is high it negates the heat spreading benefits usually found by using a thick copper wiring trace. To effectively manage the point heat flux generated by CSPs requires a different approach to the MCPCB itself.

Based on the observations of axial primacy outlined above we know that the MCPCB needs to minimize the thickness of its weakest link – the dielectric layer. Thermal resistance is thickness divided by thermal conductivity. Thermal conductivity is intrinsic to the material selected for the dielectric so the only variable available is thickness. Diamond is perfect for this application but too expensive. The dielectric cannot be too thin as it needs to maintain acceptable electrical isolation to ensure the MCPCB is compliant with relevant regulation. The dielectric layer must also be robust enough to withstand the manufacturing process and durable enough to last active service. And finally, the MCPCB stack needs to minimize the interface resistance between the various materials to maximize the composite thermal conductivity.

### Alternative Solutions to MCPCB for CSP LEDs

Almost all MCPCBs follow the same basic format in terms of their construction: They are manufactured from a sheet of metal (usually aluminum, sometimes copper) covered with a thin (30+  $\mu\text{m}$ ) layer of copper for the wiring trace. This copper sheet is attached (and electrically isolated from the metal base) by a dielectric layer of epoxy resin filled with particles of thermally conductive ceramic to increase thermal performance. However, there is an upper limit to how much of the thermally conductive ceramic can be added. Overload the epoxy with ceramic and the dielectric layer becomes friable and the adhesion to the metal substrate and copper wiring trace will be poor. Not good for a product that needs to be sturdy enough to last several decades (50,000 hours) of active service.

**Figure 4:** Graph demonstrating that for a MCPCB with adequately low thermal resistance to accommodate CSP LEDs, the copper weight has negligible impact on performance

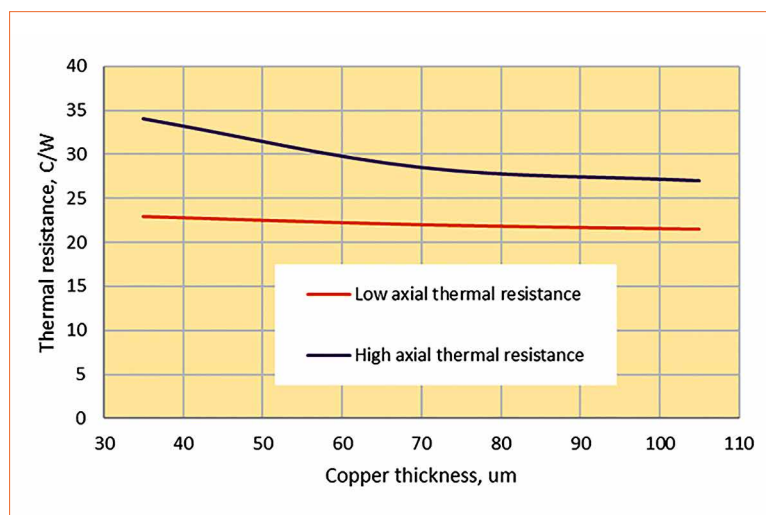

Whilst there are always new developments in these thermally conductive dielectrics there is always a trade-off between performance and durability. At the moment this limits the performance of MCPCBs to a composite thermal conductivity of well under 100 W/mK.

This thermal performance is perfectly acceptable for a majority of LED module designs, but when it comes to CSP modules, particularly for power dense designs, they simply do not offer the required performance. Historically there was only one option available to manufacturers when the thermal performance of MCPCBs fell short of requirements, and that was to move to a wholly ceramic substrate such as aluminium nitride; a material with exceptionally high thermal conductive and an exceptionally high price tag to match.

By taking the best elements of both ceramic and metal PCBs, nanoceramic utilizes the primacy of axial conduction and a low interface resistance to optimum effect.

### How Nanoceramic as Solution for MCPCBs Works

A patented electro-chemical oxidation (ECO) process converts the surface of a sheet of aluminum to a layer of alumina ( $Al_2O_3$ ) that is just tens of microns thick. Whilst alumina is not a particularly efficient thermal conductor (around 7.3 W/mK for the alumina created by the ECO process), the thinness of the layer means heat has an extremely short journey to make before hitting the aluminum base.

An interesting side effect of the ECO conversion is that the alumina layer is atomically bonded to the aluminum base. This has a significant impact on the interface resistance between

the two materials helping to reduce the overall thermal resistance of the stack. The robustness is also impressive and it is impossible to mechanically cleave the nanoceramic off the aluminum from which it was formed.

This combination of a very thin dielectric layer with relatively high thermal conductivity, atomically bonded to the aluminum base, gives a MCPCB containing nanoceramic with laminated copper an exceptional overall thermal conductivity of around 115 W/mK (the copper wiring trace are attached to the nanoceramic with a 3-5  $\mu$ m epoxy layer). This makes this product ideally suited to the demands of CSP applications.

### Conclusions

As designers continue to explore what is possible with CSP LEDs they are regularly finding their designs are outside of the capabilities of standard MCPCB technology. This thermal limit is putting a barrier in the way of innovation and a new technology is needed to fill the gap between traditional MCPCBs and expensive aluminum nitride ceramics. Nanoceramic is one material able to fill this niche. By offering a thermal performance that is tailored to the intense point flux requirements of CSP LEDs along with drop-in manufacturability, an MCPCB with nanoceramic dielectric bridges the gap between traditional MCPCBs and ceramics, enabling CSP LED designers to push the limits – creating smaller, brighter and more cost-effective light sources. ■

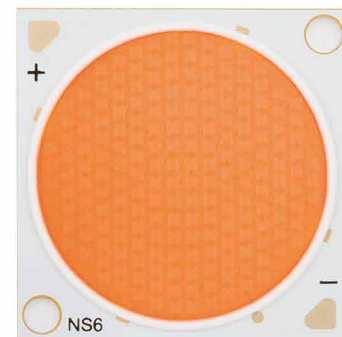
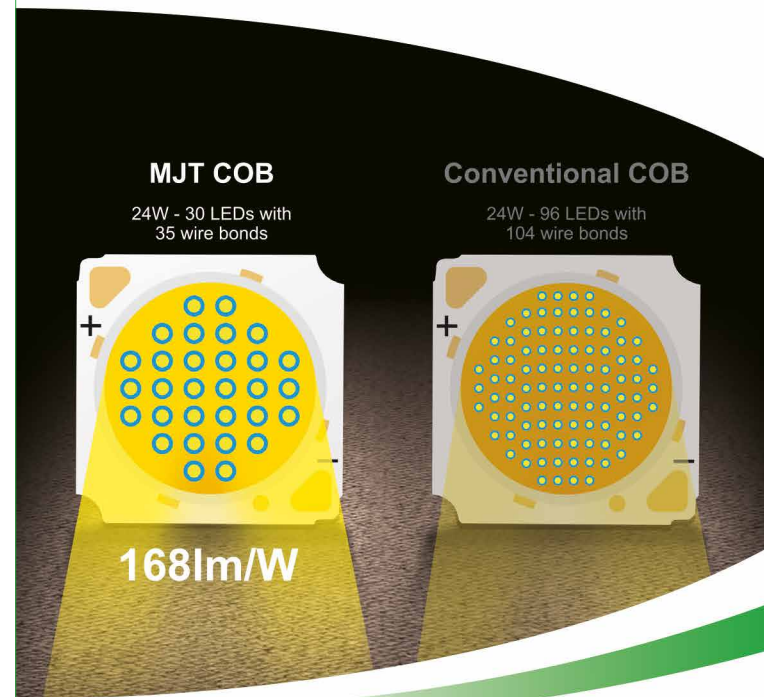

## MJT COB

**Highest Efficacy up to 168lm/W**

More reliable due to fewer wire bonds

Broad power range from 6W to 180W





# Bio-Effective Lighting for Humans, Livestock and Plants

Mood lighting is often misleadingly interpreted as HCL. But HCL is much more because it includes biologically effective light that is beneficial or dangerous, depending on the correct application. While the relevant parts of the radiation spectrum may differ, light is also biologically effective for plants and animals and it is used to achieve well-defined effects. Volker Neu, General Manager LED at Vossloh-Schwabe Lighting Solutions, presents examples, discusses similarities and differences between humans, animals and plants in respect to the relevant spectra, and scrutinizes possible consequences.

In plant growth and animal farming, a lot of research is done to find opportunities to improve growth, health and productivity. In some respects even more is known about the former than about HCL. The article sets out to detail the various biological effects of identical wavelengths on plants, livestock and humans. Current knowledge about the different genera is compared and is used as inspiration to consider possible transfers to HCL (Human Centric Lighting).

## The Status of Horticulture Lighting

Standardized use of bio-effective spectral lighting control has been common in the field of plant cultivation for quite some time. Industrial use is being made of available knowledge and intensive research conducted into further possible correlations. But findings delivered by fundamental research into plant behavior under different wavelengths are also available.

Stimulated via cryptochromes, phototropins and phytochrome, plants have been found to grow sturdier leaves and become more stress-tolerant at wavelengths of less than 400 nm (UV radiation). The above-named photoreceptors are active not only when subjected to this kind of shortwave radiation,

but also in combination with the wavelengths displayed in the graph below. In addition, low doses of UV radiation are used as a means of protection against fungal infestation.

The wavelength range between 400 nm and 500 nm produces a series of effects but does not have to be applied in high doses. Irradiation with blue light can largely prevent plants from drying out (transpiration). In the field of household appliances, modern refrigerators are provided with blue light for the vegetable compartment, which helps to keep fruit fresh for longer.

However, this wavelength range is also responsible for stunting longitudinal plant growth, which can lead to short intervals between

**Figures 1a&b:** Chlorophyll a and Chlorophyll b absorption spectrum (a) [1], and emission spectrum of a horticulture dedicated COB LED module (b) [2]

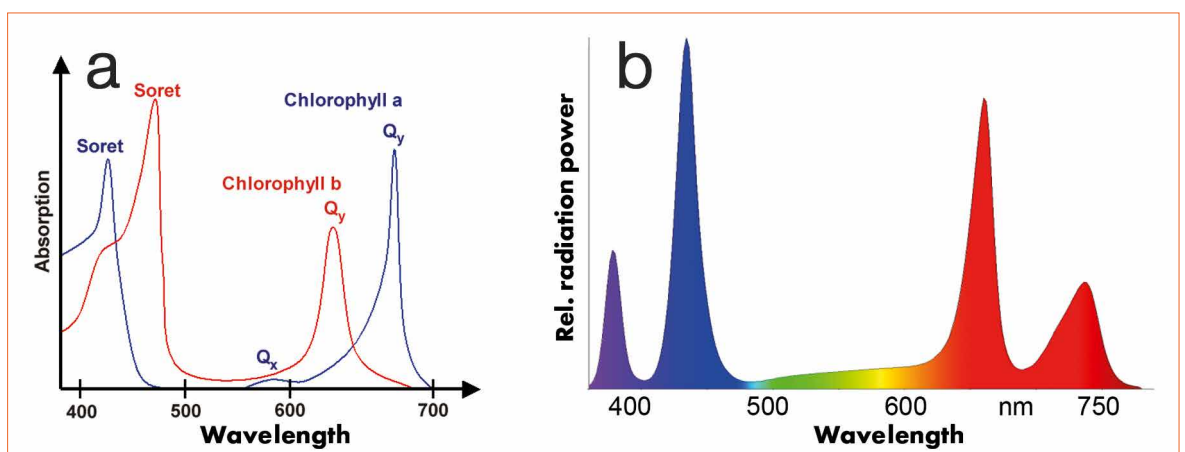

leaves (dwarfism/squat plants) and thus exerts a negative effect.

Applying light within the green wavelength range (600 nm to 700 nm) counters the growth-stunting effect of blue light and prevents short intervals between foliage tiers.

Red light (700 nm to 800 nm), in turn, causes plants to produce larger blossoms and to grow in a more compact form. This wavelength range from 700 nm to 800 nm exerts a major influence on the plant, especially on the flavor of edible plants.

As a result, correctly blending these different wavelength ranges can produce light scenarios that not only facilitate perfect plant cultivation, but also yield optimization potential with regard to energy consumption and plant quality. Energy efficiency is achieved by making spectral adjustments to suit the growth phase. Multichannel systems make it possible to suppress undesired growth factors at any given point in time. Premature illumination with longwave red light will not improve root growth. However, red light – provided at the correct point in time – will allow fruit such as vine tomatoes to ripen in a targeted manner. Ensuring fruit ripens at the same point in time maximizes harvesting efficiency. However, this spectral exposure cannot be defined via an integral value for the light source. A single  $\mu\text{mol}$  value, without any differentiation of the radiated wavelengths, makes no sense here and can only serve as an indication of the light source's output. For practical use, it is much better to split light into wavelength ranges and dedicated illumination tasks. This would be comparable to the integral Ra and the indices of the individual colors.

### Current Situation in Animal Husbandry Lighting

Use of spectrally adjustable light sources is not yet as advanced in the field of animal husbandry. While some of the effects are known

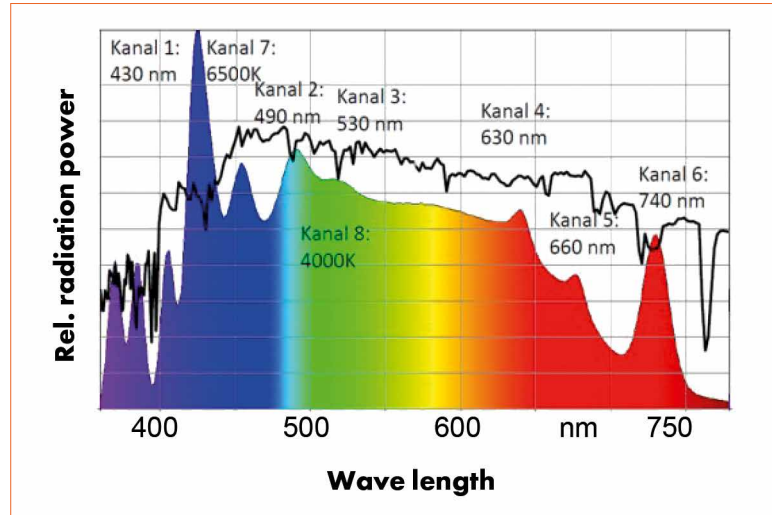

**Figure 2:** The sophisticated “Lighting Equalizer”, an 11 channel system that allows spectral tuning to better control plant growth. Besides controlling growth or larger blossoms, this system offers several additional benefits

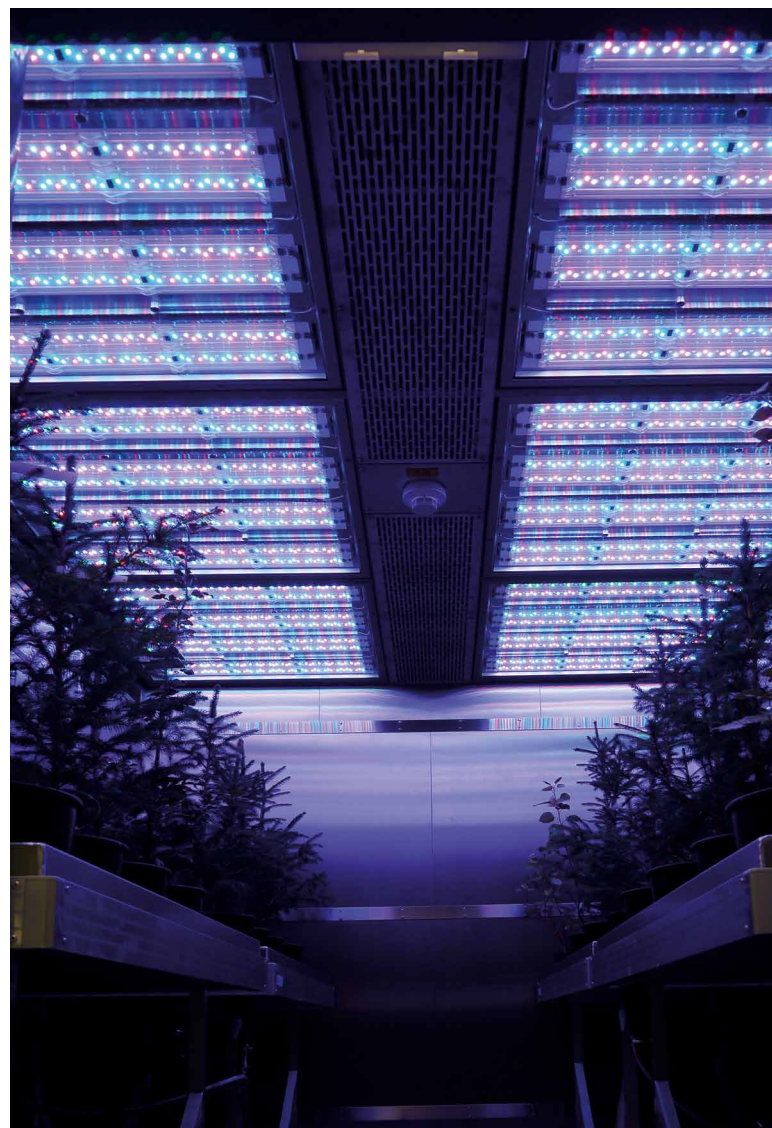

**Figure 3:** Horticulture lighting in a climatic chamber

with regard to livestock farming, the underlying biological reasons have yet to be understood. By contrast, the use of artificial lighting in livestock housing is becoming ever more common, the reasons for which can be seen

in the shift towards keeping livestock in closed sheds without daylight and the considerable global increase in the demand for meat. The demand for poultry has advanced to the number one spot worldwide and even outranks pork.

**Figure 4:** The influence of light on poultry is quite well investigated and much is known. The image shows a common practice spectral illumination in chicken farms

Poultry is inexpensive, healthy and quick to farm. For the seven-week period in which a chick grows into a 1.8-kg chicken, the following lighting scenarios are favored on the basis of currently available information. Green light results in good muscle growth during the first weeks of life, while blue light increases hormone production. As an orientation aid and to improve food uptake, a yellowy-white light is used. If chickens tend towards mutual pecking, red light can lower their aggression levels. A positive influence can also be exerted on the problem of cannibalism and the use of antibiotics, but tests have yet to be carried out on which exact wavelengths are involved. The shortwave range around 380 nm and the red range between 700 nm and 800 nm are set to be decisive for new findings. The visual spectrum of a chicken is considerably broader than that of a human. For that reason, they are difficult to evaluate using conventional light sources (adjusted to  $V(\lambda)$ ). The same is true for other poultry such as ducks, geese and turkeys.

It is also worthy of note that blue light at 480 nm keeps cows awake and increases the yield of ongoing milk production by 8%. Cows have no visual ability beyond 640 nm.

A more detailed evaluation of the influence of light on pig farming has yet to be conducted, but is not currently being pursued due to current market prices.



The operating technology constitutes another factor that exerts a key influence on lighting in such applications. Lighting should feature a particularly high resistance to flickering and scintillation.

Livestock and plants process visual stimuli considerably more quickly than humans. Operation using constant current would be the best alternative and could have a positive effect on poultry and animal health overall.

For dimming purposes, the simple PWM method should not be used, but rather it should be possible to configure a “clean” pulse control factor, which would also have to be synchronized in the case of spectral (multichannel) lighting. Failure to ensure this results in stress for livestock, which in turn has a negative effect on product quality.

### Brief Comparison Between Plants, Animals & Humans

If one now compares the known and tested “plant spectra” with those currently used in animal husbandry, it is easy to see that the dominant wavelengths are largely the same. In this context, no conclusive results can be provided with regard to the amplitudes of the spectral composition.

The influence exerted by individual light spectra as a biological stimulus for humans has barely been researched. The fact that blue light (480 nm) is known to suppress melatonin production can be seen as a first relevant step towards using HCL in the field of general lighting.

The sensitivity (receptiveness) to spectral wavelengths among plants and humans is similar to that of chickens (Figure 5).

**Figure 5:** Comparison of wavelengths and their effects in greenhouses, livestock and human centric lighting

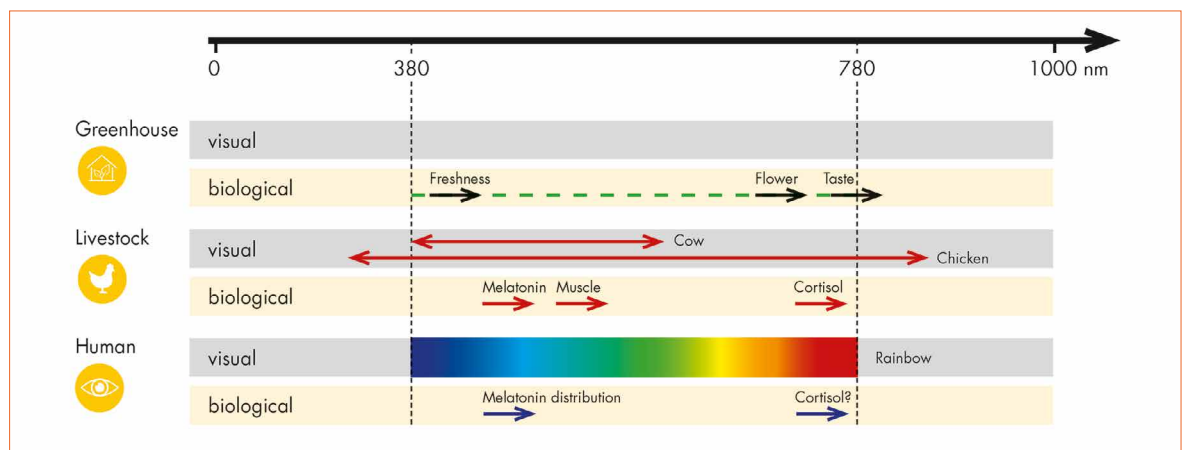



Sunlight provides the basis for all forms of life and organisms, with only the typical respective environment affecting the individual spectra: forest and desert, hill and dale, land and water. Habitat-based filtering can produce differences in this respect.

Going by the findings yielded by research, analyses and tests in all three areas (plants, livestock and humans), it appears logical to assume that further similarities between wavelength-dependent effects will be found. For instance, in chickens the stress hormone cortisol can be reduced with “red” wavelengths. Tests involving inmates in US prisons returned comparable results.

### Potential Consequences

In general, there remains a question as to the correct nomenclature for these processes and measurable factors. The human field, measured in lux and lumens, cannot be extended to wavelengths in the IR and UV ranges. Melatonin-suppression at 480 nm cannot be efficiently represented with a  $V(\lambda)$  curve. HCL does not fit within the conventional lighting profile. Given a typical invitation to tender, an HCL-compatible luminaire would lose out in terms of efficiency in lumens per Watt.

Tested parameters and representations used in established niche applications could provide a basis for a meaningful discussion. Since the effect of HCL on humans should be described via the degree of exposure, as for all other lifeforms and organisms, the unit of measure of this spectral range should be  $\mu\text{mol}$ .

However, it would be equally possible to evaluate the degree of exposure to which any one species is subjected using the sensitivity curve of the respective

genus, as is already common practice in chicken farming. But would “chicken lux” or “gallus lux” apply to all species of bird?

The effect of scintillating and flickering light, which is currently being researched with regard to humans and is resulting in new and/or improved control gear, is already well known in the field of chicken farming. Operating frequencies of up to 1 kHz exert a negative influence on the health of livestock. Further organisms with a fast “visual” response include plankton and algae. This circumstance should not be underestimated for the field of general lighting. Constant-current- powered multichannel drivers could have a positive effect on the desired result, since light would be permanently available.

### Conclusions

In the future, standard lighting practices currently found in the field of animal husbandry are also set to establish themselves in the area of general lighting. This also applies to arguments put forward in favor of HCL and its advantages since technical specifications would be largely transferrable. Clearly defined product features would be necessary to ensure planning security. ■



INTERNATIONAL

The future. Illuminated.

2017

## TRANSFORMING THE FUTURE OF LIGHT AND TECHNOLOGY

PHILADELPHIA, PA USA

Pennsylvania Convention Center

PRE-CONFERENCE

May 7 – 8, 2017

TRADE SHOW &amp; CONFERENCE

May 9 – 11, 2017

LIGHTFAIR.COM



IALD

AmericasMart  
Atlanta

PHOTO CREDITS  
LINCOLN SQUARE SYNAGOGUE, NEW YORK, NY USA |  
LIGHTING DESIGN: TILLOTSON DESIGN ASSOCIATES |  
PHOTOGRAPHY © STUDIO DUBUISSON

# SSL Growth Strategies and USDA Corn Breeding Objectives

The SSL horticulture lighting industry has become one of the fastest growing branches of lighting worldwide. Much research has already been done in regards to horticultural SSL technology and continues to be rigorously explored. While most other inputs for plant growth are monitored and controlled based on plant needs, it is still common practice for light control to be rudimentary (on/off). Brandon Newkirk, Marketing Communications Manager at LumiGrow Inc., gives a short overview on the current state of dynamic LED lighting with a focus on USDA corn breeding trials and objectives.

It has become commonly understood that supplemental lighting is an efficient way to address the shorter days and longer nights that winter's invasion brings. Seasonality carries with it diminished light intensity from the sun at various times of the year. Artificial lighting can be used to provide supplemental light in addition to sunlight to plants. Artificial light can also be the sole source of radiation for various indoor growing environments.

**Figure 1:**  
Corn breeding at the USDA lab using LED illumination

The main aspects to consider when providing light for plants indoors is the quality, intensity, and photoperiod. Quality refers to the actual wavelengths of light provided to plants. Total intensity of light at the plant canopy is crucial and is a function of light fixture intensity, beam angle, fixture arrangement, and daily light integral (DLI), which is the amount of PAR received each day as a function of light intensity. Photoperiod refers to the amount of time the plant receives light throughout a 24-hour timeline.

Different crops have different photosynthetic saturation points, where additional light beyond this point becomes

wasted. For this reason, it's important to monitor the DLI to optimize energy-use versus plant photosynthetic rates. Research institutions, commercial growers, and commercial research teams such as LumiGrow's in-house plant science research group are laying the foundational

knowledge to understand how best to use light as a growth variable for specific growth goals. As horticultural LEDs move into the ag-industry spotlight, we are in the midst of a technological paradigm shift due to increased efficiency and controllability that LED solutions offer.





# guangzhou international lighting exhibition

# 22<sup>nd</sup>

The most influential and comprehensive lighting and  
LED event in Asia

## 9 – 12 June 2017

China Import and Export Fair Complex  
Guangzhou, China

[www.light.messefrankfurt.com.cn](http://www.light.messefrankfurt.com.cn)

### Contact

Messe Frankfurt (HK) Ltd

Tel: +852 2238 9969

Fax: +852 2519 6079

[light@china.messefrankfurt.com](mailto:light@china.messefrankfurt.com)



光亞 · Guang ya



messe frankfurt



**Figure 2:**  
Absorbance spectra  
of Chlorophyll a and  
Chlorophyll b

### USDA Uses Artificial Lighting for Corn Breeding

There has already been much written about light requirements for crop production, but plant breeding remains a topic less explored. Plants have adapted to grow in certain climates, from subtropical to northern climates. Thus, the time it takes to grow from a seed to harvest can differ among different varieties, typically longer for subtropical and shorter for varieties grown in the north, as growing seasons are typically shorter in the north. Light intensities and photoperiods can further affect this, as the same variety can flower at different times if grown under different photoperiods. Although corn will flower under most photoperiods (day-neutral plant), the time to form tassels and silks (male and female flowers, respectively) will differ based on varieties. This presents a challenge for breeders who would like to cross corn, as they need flowering times and tassel formation to synchronize. Requirements are different for every corn variety but, in general, they need a high intensity of light to produce a healthy corn plant.

The USDA-ARS Station is home to the largest collection of maize germplasm in the world, which they make available for national and international research. The maize collection consists of over 20,000 accessions from all over the world. The USDA Station is using artificial lighting to aid in the development of new and more nutritious corn varieties for organic producers finally using a property called gametophytic incompatibility. They've made major advancements in the ability to prevent organic corn from being pollinated by unwanted pollen, a problem that's been prevalent in recent years due to GMO seed.

Researchers at the USDA have been using supplemental light to improve greenhouse light quality and intensity. They have used LEDs to decrease the high levels of heat from their HPS fixtures. HPS and heat is a problem with tall varieties of corn. As the corn grows closer to the high

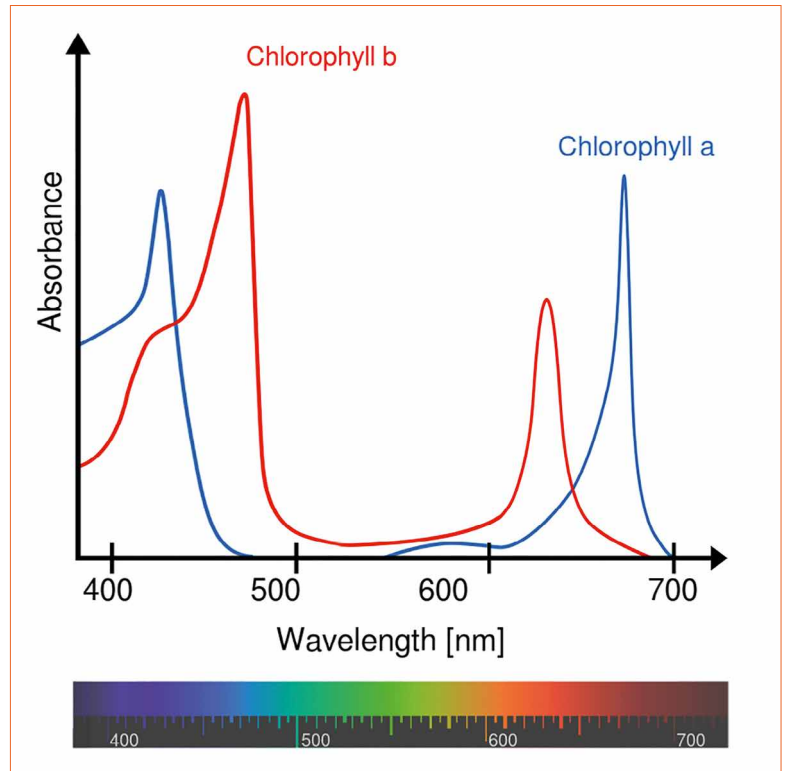

levels of heat emitted, the pollen can often become damaged. Some varieties of corn only grow a few feet in height, but others can get well over 10 feet tall. For tall varieties of corn, high ambient heat from lighting fixtures brings challenges in successful germplasm regeneration. Cooler LED fixtures offer a solution to this production system issue common to many crop breeders.

Researchers at the USDA-ARS Station have begun to experiment testing the effects of spectral variability with some interesting preliminary results. Using controllable LED fixtures to adjust the ratios of wavelengths of red and blue light emitted, they have seen increased control over growth characteristics in specific treatments. Preliminary results at the USDA Station have seen that blue light treatments can potentially induce corn to flower 3 days earlier, and plants grown under red light can have thicker stocks and more vegetative growth. More data must be gathered before any conclusive statements can be made about the significance of the results, but this is just one instance where light spectra have been used to achieve similar control over desired crop characteristics.

### Functional Differences of SSL vs. Non-SSL Lighting Strategies

Whether your goals are for breeding or production purposes, the variables between SSL and non-SSL lighting strategies remain similar. As a new technology and not simply a refinement of an existing one, SSL technology implementation requires that new variables be considered. Given the leaps and bounds that SSL technology has made in efficiency and quality compared to conventional horticultural lighting, the agricultural industry is learning fast.

As mentioned before, traditional lighting such as HPS produces more heat than LED technologies. This reduction in heat can provide major benefits, but this change can significantly affect the growth environment. Traditional growing methods have treated HPS lamps as a heat source, albeit an extremely inefficient method for temperature regulation. When implementing SSL in the form of LEDs, it's important to take note of the reduction in ambient heat, and adjust your temperature control systems accordingly.



# LED Expo Taiwan

The 13th Int'l LED Exposition  
[www.optotaiwan.com](http://www.optotaiwan.com)

**June 14-16, 2017**

TWTC Nangang Exhibition Hall

## **Featured Presentation: Automotive LED**



### **The development of new LED business patterns**

The new blue ocean market for LED: UV LED, IR LED, Proof lights, Automotive LED, jointly demonstrated in special zones



### **Total Solution @ One-stop shop in "Photonics Taiwan"**

Cross-industry platform, promotion and integration of automotive Photonics, finding best partners in Taiwan



### **Most update market trends**

International forums, new technical publications to disclose comprehensive market trends and new technologies

## **Exhibits**

### ■ **LED / OLED Light Source, Package / Module/ Engine**

LED Epi Wafer / Chip, OLED Components, LED Package, LED Module / Engine, OLED Module / Engine

### ■ **LED / OLED Lighting Fixture**

Technical Lighting  
Decorative Lighting  
Accessories and Electronic Components

### ■ **LED Applications**

Backlight, Automobile, Display Board  
Traffic Signal, Projector, IrDA, IR / UV Lights  
Others

### ■ **LED / OLED Materials**

LED Materials  
OLED Materials

### ■ **LED / OLED Equipment**

LED Equipment  
OLED Equipment



**Figure 3:** Comparison of the spectra of two LED growth lights and one HPS system with the photosynthetically active spectrum range of healthy plants

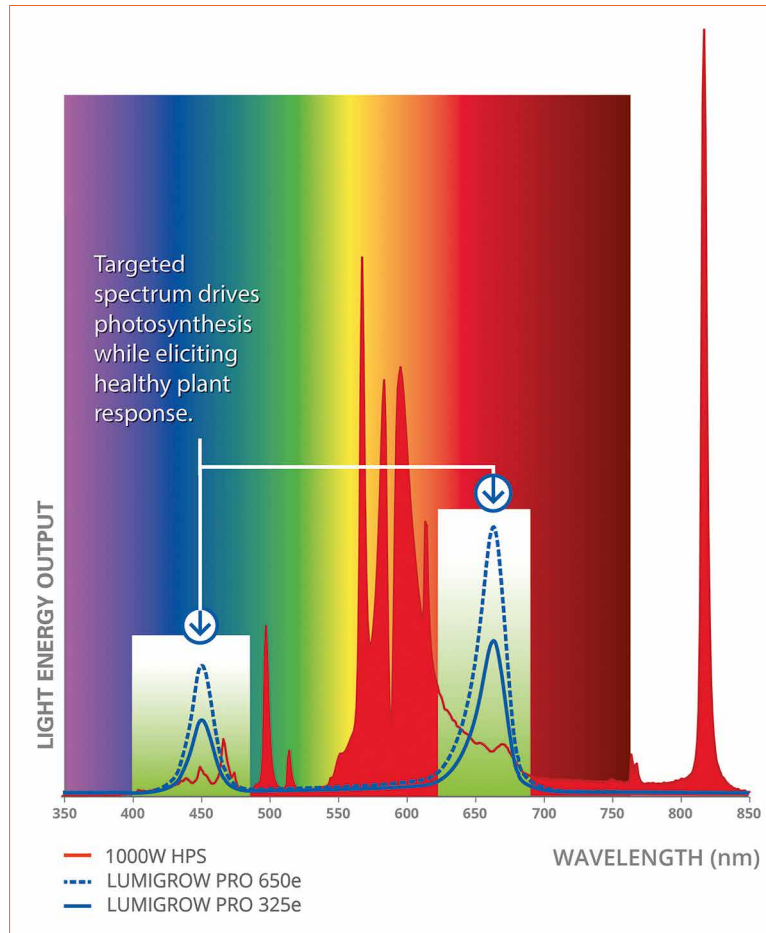

Spectral distribution is another variable when choosing to use LEDs. Different wavelengths of light have varied efficiencies in regards to photosynthesis. Rather than the human eye response curve, horticultural lighting uses Photosynthetically Active Radiation (PAR) as the primary measure. PAR refers to the spectral range from 400 to 700 nanometers, the range that plants use in the process of photosynthesis. LED technology offers the ability for lighting manufacturers to design products that target this PAR range.

### About State-of-the-Art SSL Grow Light Systems

The most up-to-date horticulture lighting fixtures take advantage of the capability for spectrum tuning and perfect intensity control to adapt for the required photosynthetic active radiation spectrum of a plant. Moreover, in high end solutions the spectral controllability can be aligned with the stage of plant growth, i.e. in some crops a blue

light treatment towards the end of flowering elicits beneficial plant response. Other plants may need a different spectral profile or prefer different light intensities during different stages of their growth. This task asks for sophisticated controls for dynamic lighting.

### Dynamic and sophisticated control solutions

Using modern control systems such as wireless solutions like LumiGrow's SmartPAR™ Wireless Control System, growers can automate lighting schedules in regards to light intensity, as well as spectral ratios as mentioned above. Furthermore, such systems allow the user to create different lighting zones from any phone, tablet or computer. Such cloud-based Horticultural lighting control systems are designed to enable growers to be more specific and dynamic with their growth strategies while providing a robust monitoring platform.

### Conclusions

When considering artificial lighting solutions for horticulture, it's important to understand the efficiency of your solution, as well as the science behind how it works. As SSL technology continues to improve, so will the automated systems that support the use of lighting tools to drive plant growth. The dialogue between plant science and lighting technology will remain important as the industry continues to rapidly evolve. It's important that horticultural experts and lighting specialists work with each other so that growers are given the best tools to continue improving their own production and research goals. Some ongoing research, for instance, takes into account biological feedback systems that could monitor how efficiently the plants are using the light for photosynthesis. It is certainly an exciting topic for the future. ■



Organizers



# ASEAN's Largest International Exhibition on LED Lighting Products & Technology



THAILAND



## EXPO 2017

### 11-13 MAY, 2017

CHALLENGER 1

IMPACT EXHIBITION & CONVENTION CENTER  
BANGKOK, THAILAND

Incorporating .....

THAILAND  
**PCB**  
EXPO 2017

THAILAND  
**ENERGY  
SAVING**  
EXPO 2017

[www.ledexpothailand.com](http://www.ledexpothailand.com)

LEDs

LED Signage  
& Displays

LED Components/  
Accessories &  
Raw Materials

LED Applications  
& Lighting

LED Drivers  
& Power Supply

LED Manufacturing  
Equipment/Machinery  
& Allied Products

LED Lighting  
Products

LED Decorative  
Lighting

## ORGANIZERS



**MEX Exhibitions Pvt. Ltd.**  
9 LGF, Sant Nagar, East of Kailash, New Delhi-110065, India  
**Ms. Himani Gulati** Tel. : +91-9312285142  
E-mail: himani@mexexhibits.com  
**Mr. Gaurav Juneja** Tel. : +91-9810301644  
E-mail: gaurav@mexexhibits.com



**IMPACT Exhibition Management Co., Ltd.**  
Bangkok Land Building, 10 Floor, 47/569-576, Moo 3, Popular 3 Road,  
Banmai Sub-district, Pakkred District, Nonthaburi 11120  
**Ms. Panvisut Buranakarn (Opal)**: Tel: +66 (0) 2833 5328, Email: panvisutb@impact.co.th  
**Ms. Wong Wing Yan**: Tel: +66 (0) 2833 5013, Email: wingyanw@impact.co.th



## LED professional Review (LpR) - Annual Subscriptions

### LpR Digital Magazine

- 6 issues
- pdf download
- high resolution pictures and graphs
- printable
- commercial use
- access to all previous issues
- Euro 78.80

### LpR Printed Magazine

- 6 issues
- Euro 158.40

<http://www.led-professional.com/subscription>

## Cover-page

Artwork: Thomas Klobassa,  
©LED professional 2017

Main Images: Arno Grabher-Meyer,  
LED professional



**BlackBody I.RAIN OLED luminaire**  
showcased at Lighting Japan

## Next LpR SYSTEMS & SOLUTIONS Issue 61 - May/June 2017

### PERFORMANCE

#### Variability in LED Production and the Impact on Performance

LEDs are subject to manufacturing deviations. These small deviations have an impact on the end product. The author reviews the surprisingly large impact on the LED performance, and on light quality, measured by all the traditional and more modern indicators like CRI but also TM-30 and the latest circadian indices. The results are explained by spectral modelling, and a variability study. The large impact, for example on CRI, even with small deviations inside the same bin, will be shown. ■

### APPLICATION TECHNOLOGY

#### Technology Challenges in Professional Tunnel Lighting Applications

The guide for tunnel lighting CIE 088:2004 is the most established international standard for the illumination of road tunnels. However, Switzerland's ASTRA (Bundesamt für Strassen) and the ASFINAG in Austria both provide guidelines that go well beyond these requirements. The article shows solutions to satisfy these requirements and explains why the commonly used value of "lumen per watt" is not a perfect method of evaluating system performance and efficiency. ■

### RESEARCH

#### "Best Papers" at LpS 2016: New Glass-Based Phosphors for White Light-Emitting Diodes

Heat-induced degradation of the polymer-based encapsulation of white LEDs results in an efficiency decrease and color temperature shift. Thus, thermal management is a key parameter for LEDs. Therefore, not only temperature stable phosphors, but also phosphors with a good thermal diffusivity are required. Luminescent glasses or glass ceramics might represent an attractive alternative to LED phosphors. Luminescent properties and the thermal diffusivity of lanthanide single and double doped glasses and glass ceramics are investigated. ■

#### Ultrathin Direct-Lit LED Module with Beam Shaping Thin-Film Optics

One expectation put on SSL luminaires are thin form factors. As it turns out, though, it is not easy to achieve without compromising quality or costs. An approach using a combination of optical foils and a color conversion foil was investigated to manufacture a direct-lit LED based lighting module that features an ultra-thin form factor and excellent light quality at a reasonable cost. For more demanding applications, a solution with colored LEDs to compensate the color shift of white LED is also proposed. ■

subject to change

## Imprint

LED professional Review (LpR), ISSN 1993-890X

### Publishing Company

#### Luger Research e.U.

Institute for Innovation & Technology  
Moosmähdstrasse 30  
A 6850 Dornbirn, Austria / Europe  
phone +43 5572 39 44 89  
fax +43 5572 20 60 70  
info(at)lugerresearch.com  
www.lugerresearch.com

#### Publisher

Siegfried Luger +43 699 11 33 55 70  
s.luger(at)led-professional.com

#### Editor-in-Chief

Arno Grabher-Meyer +43 699 11 33 55 18  
a.g-m(at)led-professional.com

#### Int. Account Manager

Theresa Koenig +43 699 11 33 55 20  
theresa.koenig(at)led-professional.com

#### Marketing & Sales Manager

Theresa-Anna Luger +43 699 11 33 55 19  
theresa.luger(at)led-professional.com

### Your Local Contacts

#### China, Hong-Kong

Iris Yuen +86 1380 27 01 367  
irisyuen88(at)gmail.com

#### Germany & Switzerland

Armin Wezel +49 30 526 891 92  
armin(at)eurokom-media.de

#### India

Priyanka Rai +91 124 478 7331  
priyanka.ra(at)binarysemantics.com

#### Japan

Eiji Yoshikawa +81 3 6751 0090  
scala(at)s3.dion.ne.jp

#### South Korea

Jung Won Suh +82 2 78 58 222  
sinsegi-2(at)sinsegi-media.info

#### Taiwan

Leon Chen +886 2 256 81 786-10  
leon(at)jkm-media.com.tw

#### United Kingdom, France & Benelux

Zena Coupé +44 1923 85 25 37  
zena(at)expomedia.biz

#### US East

Karen C Smith-Kernc +1 717 397 7100  
KarenKCS(at)aol.com

#### US West & Canada

Alan A. Kernc +1 717 397 7100  
AlanKCS(at)aol.com

## Copyrights - Luger Research e.U.

The editors make every reasonable effort to verify the information published, but Luger Research e.U. assumes no responsibility for the validity of any manufacturers, non profit organizations or individuals claims or statements.

Luger Research e.U. does not assume and hereby disclaims any liability to any person for any loss or damage caused by errors or omissions in the material contained herein, regardless of whether such errors result from negligence, accident or any other cause whatsoever. You may not copy, reproduce, republish, download, post, broadcast, transmit, make available to the public, or otherwise use LED professional Review (LpR) content without prior written consent from Luger Research e.U. - Institute for Innovation & Technology, Austria. ■



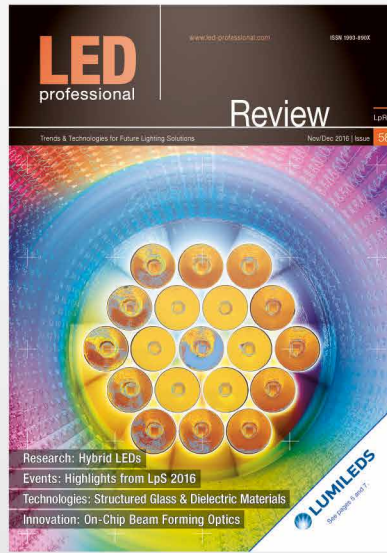

**!** GET YOUR FREE E-MAGAZINE  
[www.led-professional.com/free](http://www.led-professional.com/free)



# Trends & Technologies for Future Lighting Solutions.

LEDs • OLEDs • Light Engines • Lighting Modules • Optics • Drivers • Thermal Management • Lamps • Fixtures • Production & Measurement Equipment Project Reports • Patent Reports • Research Reports • Event Reports

**LED**  
 professional

MORE THAN  
**31,500**  
 READERS

[www.led-professional.com](http://www.led-professional.com)

powered by Luger Research e.U.

Submit your article. Please contact Arno Grabher-Meyer, Editor in Chief, at [a.g-m@led-professional.com](mailto:a.g-m@led-professional.com)



# ACEVEL

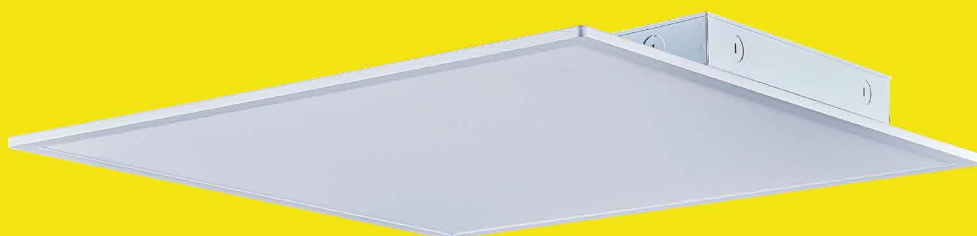

**Fair: USA SIL Lighting**  
**Booth: Booth 624**  
**Hold in: Anaheim, CA**  
**Time: Feb 28 - March 2, 2017**

**ACEVEL GROUP | [www.acevel.com](http://www.acevel.com) | [info@acevel.com](mailto:info@acevel.com)**