



Tech-Talks Bregenz: Guido van Tartwijk

Research: Micro-Optics & Medical Devices

Engineering & Technology: Data, Optics, IoT & Cooling

Events: LpS & TiL Planning and Program

FUTURE
Lighting Solutions
www.FutureLightingSolutions.com

PLEASE VISIT US
AT BOOTH A17

LpS 2018
LED SYMPOSIUM
+ EXPO



Lighting that captivates shoppers—and moves merchandise.

Lighting is essential in creating a unique shopping experience that helps retailers attract repeat business. For any effect your retail customers demand, choose Lumileds High Impact Retail Lighting Solutions for your luminaire designs.

This complete portfolio of LEDs for High Impact Retail helps you distinguish each retailer's brand through differentiated, consistent experiences. The CrispColor and CrispWhite Technologies featured in the LUXEON Stylist Series can be precisely tuned for signature colors and showcasing merchandise. And you get best-in-class performance and efficiency with every LED, CoB or ready-to-deploy Matrix Platform configuration.

To find out more, visit lumileds.com/StylistSeries or contact your Lumileds Sales Representative.



LUMILEDS ILLUMINATION LEDs

LUXEON HIGH POWER LEDs • LUXEON MID POWER LEDs • LUXEON CoB LEDs • LUXEON COLOR LEDs • LUXEON IR • MATRIX PLATFORM

Exclusive. Extraordinary. FREE.

UPDATED VERSION 1.2 AVAILABLE
DESIGN YOUR LUMINAIRE NOW!
<http://www1.FutureLightingSolutions.com/LSC>

Over 100,000 Lighting Simulations Completed with Future Lighting Solutions' Lighting System Creator Design Tool

The Lighting System Creator is a free online design tool offered by Future Lighting Solutions which enables the user to seamlessly create an entire lighting system. Powered by a proprietary algorithm leveraging light source LM-80 data, the LSC automatically provides appropriate and application specific light sources based on value engineering principles, determines the optimal forward current and temperature to meet target flux, efficacy and L70 lumen maintenance values.

- The LSC will optimize the temperature and current to minimize the LED count and suggest the most cost effective approach to meet target specifications using LEDs, COBs, and even modules and integrated light engines.
- In cases where the user wishes to consider one specific type of light-source for the application, the user can now specifically select their preference versus being presented with all possible technical solutions.
- The LSC now also includes light sources that do not yet have an available LM-80 report. This now enables users to consider recently released products for design consideration in to their fixtures.
- The tool also includes an automatic offset that incorporates the efficiency impact of the integrated driver and/or integrated optic for modules and light engines when applicable.



Visit Future Lighting Solutions at:
BOOTH A17

FUTURE
Lighting Solutions
Making LED Lighting Solutions Simple™

www.FutureLightingSolutions.com

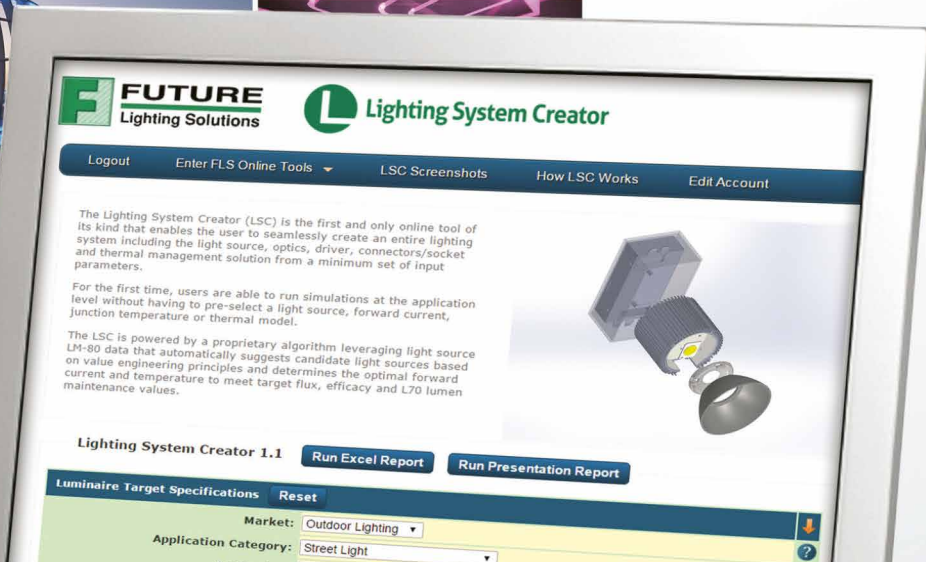



LpS / TiL 2018 - The Lighting Events

After months of preparation the starting bell for the 8th International LpS event and the 2nd TiL event is about to ring.

In the following, I'd like to highlight a few key questions that will be examined in Bregenz:

What do the leading lighting organizations say about the future of the light? Where is our journey going? How does dynamic beam shaping work and what technologies are available? Is LiFi technology ready to use? What flexible OLED technologies are there? How do I plan rooms with new light planning tools? How and what can we learn from other industries and new applications? How do digitization, networking and miniaturization affect new solutions? Do we understand the potentials of Semantic Lighting? Why do cyber security and IoT make us nervous? How do we learn from natural light? How can we expand our creative thinking with new materials, processes and design tools?

Is modularity key for future designs?

The LpS program is segmented into the topics of: Strategies and Technologies, Quality Engineering, Digitalization, HCL, and Technologies in Applications. On the other hand, the Trends in Lighting program will focus on Lighting Heart & Soul, The Right to Create, Humanized Tech, and Beyond Illumination.

Join our annual events and be inspired by over 100 leading experts in the fields of light, architecture, design, communication, medicine, transportation and horticulture, to name just a few.

This LpR issue contains an overview of the complete program and articles related to the above key questions.

Have a good read.

Yours Sincerely,

Siegfried Luger
Publisher, LED professional

It is not just men's
rear ends that women
stare at nowadays,
but cars', too – thanks
to PLEXIGLAS®.

What does a leading specialty chemicals group have to do with car design? For over 60 years, Evonik, with its PLEXIGLAS® molding compounds, has been a driving force behind the auto industry. Why? Because the multifaceted ways in which PLEXIGLAS® can be formed open up virtually endless possibilities for design. One shining example is transparent and colored PLEXIGLAS® whose top transmission properties and color stability make for automotive lighting that's as striking as it is innovative. For more inspirational PLEXIGLAS® products, go to www.plexiglas-polymers.com.

PLEXIGLAS® 



 **EVONIK**
POWER TO CREATE

COMMENTARY

- 08 A New Lighting Scene
by Rogier van der Heide, Curator of Trends in Lighting 2018

EVENTS

- 34 Planning Your LpS 2018 Is Easy with Our Simple Program Chart and Event App
by Bronwen Rolls, Trends in Lighting
- 36 LpS&TiL 2018 EVENT PROGRAM

ORGANIZATION SPECIALS

- 42 Zhaga Enables Mechanical IoT-Upgradability for Outdoor LED Lighting Fixtures
by Dee Denteneer, Zhaga
- 48 Evaluating Performance of LED based Luminaires
by Various Experts from LightingEurope

TECH-TALKS BREGENZ

- 56 Guido van Tartwijk, CEO of Tridonic
compiled by Guenther Sejkora, LED professional

RESEARCH

- 64 Smart Design of Freeform Micro-Optical Elements for Thin Direct-Lit Luminaires
by Christian Sommer et al., Joanneum Research Forschungsgesellschaft
- 70 Optical Designs to Improve LED Lighting Efficiency of Medical Endoscopes
by Alexander Gaertner & Paola Belloni, University Furtwangen

ENGINEERING

- 76 Rethinking the Photometric Data File Format
by P. Eng. (Ret) Ian Ashdown, SunTracker Technologies
- 82 Additive Optics Design and Fabrication for Smart Lighting Systems and Tailored Project Solutions
by Marco de Visser et al., Luximprint & Physionary

TECHNOLOGY

- 88 Qualified Bluetooth Mesh – Making Lighting Controls Future-Proof
by Patrick Durand, Future Lighting Solutions
- 94 Materials, Manufacturing and Technologies for Designing Passive Cooling Devices
by John Broadbent, Columbia-Staver

APPLICATIONS

- 98 Interactive Lighting Control is Opening New Doors for LED Application
by Manjinder Benning, Limbic Media

TRENDS

- 104 Approaching the Spectrum of the Sun
by Marc Juarez, Seoul Semiconductor

REGULARS

- 04 EDITORIAL
- 08 COMMENTARY
- 10 COMPONENTS NEWS
- 24 APPLICATIONS NEWS
- 26 RESEARCH NEWS
- 32 REGULATION NEWS
- 40 CIE RESEARCH

- 110 ABOUT | IMPRINT

HIGHLIGHTS

- 76 Rethinking the Photometric Data File Format
by P. Eng. (Ret) Ian Ashdown, SunTracker Technologies



- 88 Qualified Bluetooth Mesh – Making Lighting Controls Future-Proof
by Patrick Durand, Future Lighting Solutions

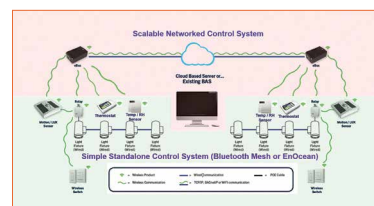

ADVERTISING INDEX

FUTURE LIGHTING SOLUTIONS	1	HEP	21	TIL	55
LUMILEDS	2	ELT	23	TRIDONIC	61
FUTURE LIGHTING SOLUTIONS	3	OPHIR SPIRICON	25	FLS-SIGNIFY	63
EVONIK	5	ELECTROLUBE	27	INSTRUMENT SYSTEMS	69
FLS-NICHIA	7	GL OPTIC	28	MOUSER ELECTRONICS	75
FLS-LUMILEDS	9	WAGO	28	SEOUL SEMICONDUCTOR	87
ELECTRO TERMINAL	11	LACKWERKE PETERS	29	ACAL BFI	103
LIFUD	13	WAGO	29	GUZHEN LIGHTING EXPO	109
EDISON	15	GRE ALPHA ELECTRONICS	31	LPR	111
INSTRUMENT SYSTEMS	17	CREE	33	WÜRTH	112
FUTURE LIGHTING SOLUTIONS	19	FULHAM	39		
LACKWERKE PETERS	19	LPS	47		



Let your light come to life
WITH NICHIA'S COLOR

NICHIA's Direct Mountable Chip Colors Series

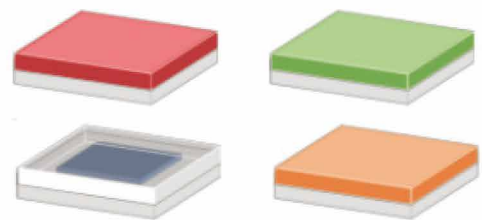

Colors

- Red
- Green
- Royal Blue
- Amber

Applications

- High End architecture
- Emergency vehicle
- Stage lighting
- And more...

Features

- Phosphor converted
- Same footprint / same height
- Same forward voltage
- Red stable at higher temperatures

Request Your **FREE** Samples Now!
www.bit.ly/FLSNichiaSamples



www.NICHIA.com



Making LED Lighting Solutions Simple™

www.FutureLightingSolutions.com



Rogier van der Heide

Rogier van der Heide is not only one of the world's best-known lighting designers, but also a recognized c-suite executive specialized in enabling sustainable business growth by design. Rogier's current agenda of key topics includes Open Innovation, IoT, Foresighting, Branding, and the Convergence of Disciplines such as Design, Marketing and Technology. As a lighting designer, he led Arup Lighting for eight years, and has worked for over 30 years on some of the most challenging projects worldwide, often recognized with the most prestigious awards. He continues to work in lighting design, while at the same time advising corporations on design strategy, and teaching at the university. Rogier is the curator of Trends in Lighting 2018 in Bregenz: The leading lighting design event, owned and organized by Luger Research.

A NEW LIGHTING SCENE

I wouldn't be telling you anything new if I said that technology is changing at an ever-increasing rate. But in the lighting industry there is a lot more happening, which makes these times truly disruptive and perhaps even inconvenient for some people ... but not for me.

Gone are the times that a manufacturer could sell lamps and luminaires with big margins, using known technologies, illuminating the world one lux at the time and repeating concepts and specifications for years and years without substantially changing anything. Gone are the times that a lighting designer could draw his plans like "ambient lighting, accent lighting, specialty lighting" and analyze them for uniformity and reflection factors on his laptop. Gone are the times that retailers install ceiling panels, 60x60 cm, with a luminaire every 2.4 meters. Things were comfortable then because there were no unknowns and everyone got his share. But those days are gone!

Can you remember when digital music was introduced? It was 1983, and my father - a musician nota bene - took me to the audio/visual tradeshow. Philips introduced the compact disk; and suddenly everything changed. Music became replicable with no loss and with the arrival of CD burners everyone could become a music label! I was thrilled. Digital technology was extremely empowering and sooner rather than later, I started to compose music, distribute it, market it and enjoy all of it on a computer - and later on I could use my phone.

Can you remember the arrival of digital photography? In 1996 I bought a Philips digital camera (the ESP-2) and we were all blown away by the new possibilities it offered us as designers! I showed it off in Tom Hennes' office in New York City. The people there couldn't believe their eyes! We started to brainstorm what we could do with it: make affordable presentations, show images to clients on our computer, take snapshots at an extremely low cost and be much faster turning around design pilots and experiments. My camera only had

VGA resolution (does that mean anything at all to millennials?) but we didn't care: Digital technology offered opportunities to improve our work and we understood the affordability and accessibility of it. That is the real empowerment of digitization: it offers new possibilities and it is extremely democratic.

Things are the same now with lighting. Many professionals are concerned, just like many photographers and photography corporations were in the nineties. Many lighting people feel that LED is not only a new opportunity but also a threat, and many are forced to re-think their profession because with digital tech comes a new paradigm of how you do your work and what you deliver to your clients. I am excited about the new opportunities! Today, lighting doesn't only illuminate. Sure, it still shapes and articulates the buildings, cars, spaces and objects that surround us, but now that it's digital it can do so much more. Light is for entertainment, health, wellbeing and productivity. Light gives identity, heart and soul, color and spirit. And the beautiful thing is: everyone is a lighting designer! Across all industries, light can contribute to making better products and giving better experiences. And to be successful in doing so, one requires an understanding of digital technology, and more importantly, comprehension of the way people shape their digital world around their desires to express, create, connect, experience and transform.

Trends in Lighting 2018 is meant to encourage just that: the cross-discipline, professional and creative application of digital light, and we embrace all the opportunities that come with the changes in the industry. We aspire to demonstrate a vision: that lighting design is not limited to architecture and to luminaires, and instead encompasses design in the broadest sense, as well as a sound understanding of the digital ecosystem, and a keen and curious mind to spot the opportunities to do as much with light as you can possibly imagine.

I am looking forward to shaking hands with you in Bregenz! ■

R.v.d.H.



Lumileds Matrix Platform

Infinitely configurable, integrated LED light engines tailored to the most demanding design requirements. Yours.

In addition to a robust portfolio of off-the-shelf products, Matrix Platform includes a portfolio of exclusive **Advanced Technologies**:

Integrated Light Guides

- Incorporates thin or ultra-thin optics for non-pixelated light emission
- Delivers controllable light distribution that ensures visual comfort
- Enables fixtures to meet DLC Premium
- Awarded the 2018 Architectural SSL Product Innovation Award

Oberon Intelligent Assembly

- The industry's only LED-mixing system that guarantees board-to-board consistency
- Picks LEDs at a tile or wafer level using proprietary algorithms, versus traditional tape and reel
- Allows Lumileds to deliver much tighter distributions compared to standard binning and kitting

Integrated Drivers with application-specific topologies custom fitted to a manufacturer's needs

Connectivity and Controls intelligently integrates to support a full spectrum of wired and wireless protocols

Color Tuning Electronics includes patented dim to warm circuitry that pairs perfectly with single channel drivers for improved aesthetics and functionality

A selection of Matrix Platform products:

LUXEON XF-3014 CV

- 112 lumens per 96mm segment with 110 lm/W efficacy at 24V, T_J=50°C
- 2700, 3000 and 4000K CCT offerings with 80CRI
- <2% light output attenuation over 10m length

Configurations :

- 6 LEDs per segment, cuttable every 96mm
- 6 LEDs, 96mm segments with connectors
- 30 LEDs, 480mm segments with connectors

LUXEON XR-M

- Typical 3200–5300 lumen building blocks with 140 lm/W efficacy @700mA, T_c=85°C
- Available in 70CRI 4000K, 5000K and 5700K
- May be used with off-the-shelf individual lenses and lens plates for easy system integration
- 3, 4 and 5 LED linear board options and 4 LED square board option for design flexibility and luminaire adaptability
- MCPCB for efficient heat dissipation and mechanical robustness

LUXEON XR-TX

- Typical 3300 lumens with 140 lm/W efficacy at 700mA and 85°C board temperature
- A range of CCT options available in 70CRI (4000K–5700K)
- 150mm length x 45mm width footprint designed for use with standard third party optics
- Features industry's highest efficacy single die emitter—LUXEON TX



Lumileds Wins
Architectural SSL
Product Innovation
Award (PIA)

Category: COMPONENTS

Matrix Platform Integrated Light Guide



To find out more on LUMILEDS Matrix Platform,
visit **FutureLightingSolutions.com** or contact your local FLS representative.

TT Electronics - IR LED Emitter has Narrow FWH Angle

TT Electronics, a global provider of engineered electronics for performance critical applications, has introduced a compact, infrared LED emitter with the industry's largest spot diameter of 7 mm for super-reliable optical sensing and position encoder applications.



TT Electronics' new IR LED Emitter has market-leading 7 mm spot size and high on-axis intensity to ensure dependable detector response

With up to 10 mW total radiated power at the maximum drive current of 100 mA, and 2.25° angle of half intensity, the OP207CL couples optical flux extremely efficiently onto the receiving photo-sensor to ensure clearly detectable on/off transitions. The integrated collimating lens creates a tight beam profile for use with accuracy-dependent devices such as radial or linear encoders for absolute or incremental measurement, as well as long-range light curtains, edge detectors, scanners, and general optical sensing and switching.

Having a wide operating temperature range of -40°C to 105°C, the OP207CL can withstand demanding environments in a wide range of applications including industrial automation, safety systems, robotics, security detectors, or other equipment requiring dependable position, proximity, or motion sensing.

The surface-mount LED with integral molded lens comes mounted on a 9.9x9.9 mm PCB substrate. The compact footprint and height of only 6.3 mm allow use in space-constrained situations. The GaAlAs LED emits wavelengths in the 840-870 nm near-infrared range for good spectral matching with silicon photo-sensors, and the typical rise/fall time of 22 ns ensures fast response to turn-on/off signals. ■

Cree's XP-G3 S Line - Optimized for Connected Lighting

Cree, Inc. announces the XLamp® XP-G3 S Line LED, an extension of the industry-leading XLamp XP-G3 LED that is optimized for the connected lighting future. With the XP-G3 S Line, Cree delivers high-power LED technology optimized for long-lifetime, high-power general lighting applications where sensors and the Internet of Things (IoT) are becoming common, such as commercial indoor, parking, industrial and roadway.

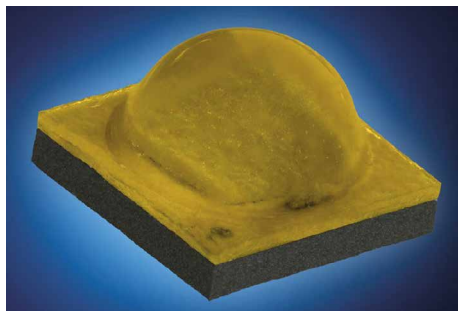

Cree's new XLamp XP-G3 S Line LED combines best-in-class reliability and efficacy, addressing the requirements for connected lighting

Connected lighting systems use information from occupancy sensors and other sources to continuously react to the target environment, dimming or switching off unneeded lights to conserve energy. On average, a connected lighting system will dim or switch off lights up to 10 times more often than with a standard lighting system. These additional dimming and switching cycles put more stress on the LED system and can limit the luminaire's lifetime. Through innovations in component architecture, the new XLamp XP-G3 S Line LED can withstand double the number of switching cycles when compared to competing LEDs in its class.

The new XP-G3 S Line LED further improves the standard XP-G3 with better reliability through switching and dimming cycles, improved resistance to sulfur exposure and higher light output and efficacy. This more robust version of the XP-G3 LED delivers excellent LED system reliability in all lighting applications, including those with harsher environments.

The XP-G3 S Line LED provides an easy upgrade path for existing XP-based LED systems, allowing manufacturers to quickly implement these LED innovations into their designs. Product samples are available now

and production quantities are available with standard lead times. The XP-G3 S Line LED has LM-80 data available to enable luminaires to immediately meet the requirements for DesignLights Consortium® qualification. ■

LG Innotek Introduces "Visible Disinfection Lighting" Solution

LG Innotek announced "Visible Disinfection Lighting", which is a functional light source that gives the effect of sterilization by sunlight with the indoor light. The LED realizes the effect of eco-friendly sterilization, that is, the method used to dry household goods and blankets under the sun, in indoor spaces conveniently and safely at any time.

Bacteria have a characteristic that they become extinct when exposed to sunlight for a long time. It is because of a material called "porphyrin" inside of bacteria which destroys its cells by reacting with certain wavelengths of sunlight. LG Innotek created "Visible Disinfection Lighting" by maximizing the use of the 405 nm wavelength to which porphyrin reacts most actively, with its unique LED light extraction technology.



LG Innotek announced new LED packages for "Visible Disinfection Lighting"

Using LG Innotek's "Visible Disinfection Lighting" one can easily sterilize an indoor space without having to use any chemicals. According to the result of the sterilization power test on Hygienic Light LED by Korea Conformity Laboratories (KCL), 99.9% of Escherichia Coli get killed.

Especially since this product does not harm the human body, its sterilization function can be used without any worries in places where many people pass by such as kitchens or restrooms. The product is verified that it does not have any negative effect on the eyes or skin, from the Photobiological

Safety Standard (IEC62471) of International Electrotechnical Commission, an international standard for electrical technology.

"Visible Disinfection Lighting" of LG Innotek can optimize sterilization power according to the indoor conditions in the same way as one controls the brightness of the light.

LG Innotek plans to actively promote "Visible Disinfection Lighting", aiming at local and international LED lighting manufacturers. Since the sterilization effect and safety of this product have been proven, The company can actively promote the product to apply it to facilities related to health & medical treatment and other public places such as food & drug-related facilities or public restrooms.

In fact, LG Innotek has already installed this product in the coffin rooms of funeral halls and waste storage rooms in Yonsei University Severance Hospital Seoul as a trial. The product has received positive responses as it enhances the sterilization effect and gives a psychological relief at the same time.

LED lighting manufacturers can now efficiently and stably produce differentiated lighting with the supply of this LED. This is possible thanks to the company's quality competitiveness that comes from owning the core technology and production lines for the light source. The manufacturers can design various types of lighting, including flat panel, tube, and down light types. ■

Vishay Automotive LEDs - AllnGaP Technology in Smallest Chip Size

Vishay Intertechnology, Inc. introduced two new series of surface-mount Automotive Grade power LEDs in PLCC-2 and ultra-compact MiniLED packages. Utilizing the latest advanced AllnGaP technology in the smallest chip size available, the Vishay Semiconductors VLMx335xx and VLMx235xx series deliver high brightness and maximum drive current up to 50 mA for automotive, industrial, and consumer applications.



Samples and production quantities of Vishay's new LED series will be available in Q4 2018

The AEC-Q101 qualified LEDs released combine low thermal resistance down to 400 K/W with power dissipation of 130 mW, which in turn enables their high drive current. The small 2.3 mm by 1.3 mm by 1.4 mm size of the VLMx235xx's MiniLED package and VLMx335xx's high luminous intensity to 1400 mcd make them ideal for automotive interior and exterior lighting; traffic signals and signs; and indicators and backlighting for audio and video equipment, LCD switches, and symbols for general use.

Offered in super red, red, amber, soft orange, and yellow, the LEDs feature a



**ELECTRO
TERMINAL**

**" WE CONNECT
WITH PASSION.**

SLK 7
OUR SUPER FLAT ONE.

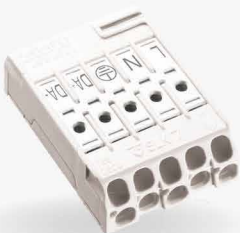

**MICROCON
SMD PURE**
OUR NAKED SOLUTION.



MICROCON SMDP
OUR STRONG ONE.



lead-frame embedded in a white thermoplast, with an inside reflector filled with a clear epoxy. The devices offer a $\pm 60^\circ$ angle of half-intensity, forward voltage down to 1.8 V, a luminous intensity ratio per packing unit of ≤ 1.6 , and are categorized, per packing unit, for luminous intensity and color.

RoHS-compliant, halogen-free, and Vishay Green, the LEDs are available in 8 mm tape, offer an ESD-withstand voltage up to 2 kV in accordance with JESD22-A114-B, and are compatible with preconditioning according to JEDEC Level 2a.

Samples and production quantities of the VLMx335xx and VLMx235xx series will be available in Q4 2018, with lead times of six weeks. ■

New IR LED for Razor Sharp Images of CCTV Surveillance Cameras

Osram Opto Semiconductors is expanding its proven Oslon Black portfolio for infrared illumination with the addition of an infrared LED with a narrower beam angle of $\pm 25^\circ$. Thanks to the new SFH 4718A IRED, illumination units for camera systems with a medium capture range no longer require secondary optics.



Osram's new SFH 4718A cuts the size and cost of illumination units for CCTV systems with a medium capture range

The Oslon Black family now offers a wide selection for the most varied of infrared-based applications, taking in four power classes, three wavelengths and three beam angles. The Oslon Black series from Osram Opto Semiconductors spans all types of infrared illumination. Key applications include the illumination of areas monitored by closed-circuit television (CCTV) systems using infrared light. CCTV is used, for instance, to monitor public spaces,

parking lots and company premises, as well as museums and bank foyers. Adding infrared illumination ensures that the camera delivers high-quality images regardless of the prevailing light conditions. The IRED can also be used for automatic license plate recognition systems.

In the low output range a new version with a narrower beam angle of $\pm 25^\circ$ is now available on the market. Particularly for camera systems with a medium capture range this means that the illumination unit can be designed without additional secondary optics. This makes the overall system more compact and cost-effective. At the same time, the SFH 4718A provides an excellent radiant intensity of 730 W/sr. At a current of 1 amp, the IRED offers an optical output of 0.8 watts (W). Their 850 nm wavelength is barely discernible by humans, but lies firmly within the sensitivity range of the camera sensors. ■

LG Innotek Unveils Less Blue Light Emitting "Eye Pleasing" LED

LG Innotek announced that it released an "eye-pleasing (EP)" LED, a functional LED package for the first time in the world. "EP LED" is a lighting LED of a new concept inspired by previous research on the interaction between light and eye. The company applied its proprietary technology for designing LED chips to control the wavelength of light.



LG Innotek claims their new proprietary EP LED technology is easier on the eyes than conventional LEDs or even sunlight

In fact, "EP LED" controls the wavelength of "blue light", which corresponds to 380-500 nm of the visible light. It generates by up to 60%~70% less of the wavelength from 415 to 455 nanometers than the sunlight or the former LEDs, which is known to generate reactive oxygen in the retina and give stress to the eyes.

The "EP LED" can also be used to create a light that can improve cognitive ability and concentration compared with conventional white LED products. This is possible because EP LED emits a wavelength between 465 and 495 nm of which wavelength is known to activate the physiological function of a human body up to 20% more than natural sunlight does.

EP LED product can be also used with color temperature tuning solution in office, retail, or hospital environment. It can activate the biorhythm with the high color temperature close to the natural sunlight. In addition, it can improve the sense of stability of people and patients in the lounge or the hospital patient rooms with the low color temperature.

The "EP LED" also fully capitalizes on the advantages of LED lighting. Compared to the conventional method of attaching a filter to the lighting to reduce harmful wavelength, the "EP LED" minimizes the loss of optical efficiency and color.

LG Innotek secured the quality and stability of the products by installing the "EP LED" lighting in its new plant in Pyeongtaek, Gyeonggi-do. ■

Cree Adds XLamp XP-G2 High Efficacy (HE) LED To Boost Efficacy

Cree, Inc. announces the new High Efficacy (HE) version of the XLamp® XP-G2 LED that delivers improved performance compared to standard XP-G2 LEDs, with higher output and greater efficiency to enable smaller, lighter, lower-cost designs. The original XLamp XP-G2 LED pioneered a broad set of LED applications for the industry, including outdoor and area lighting.

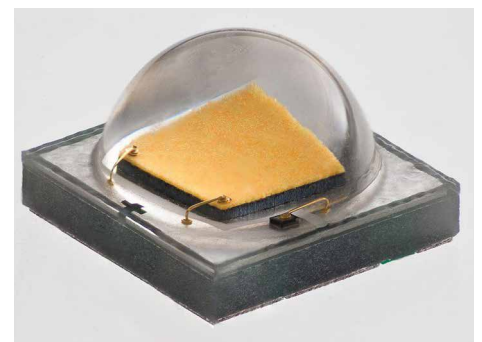

XP-G2 HE LEDs consume less power with drop-in compatibility

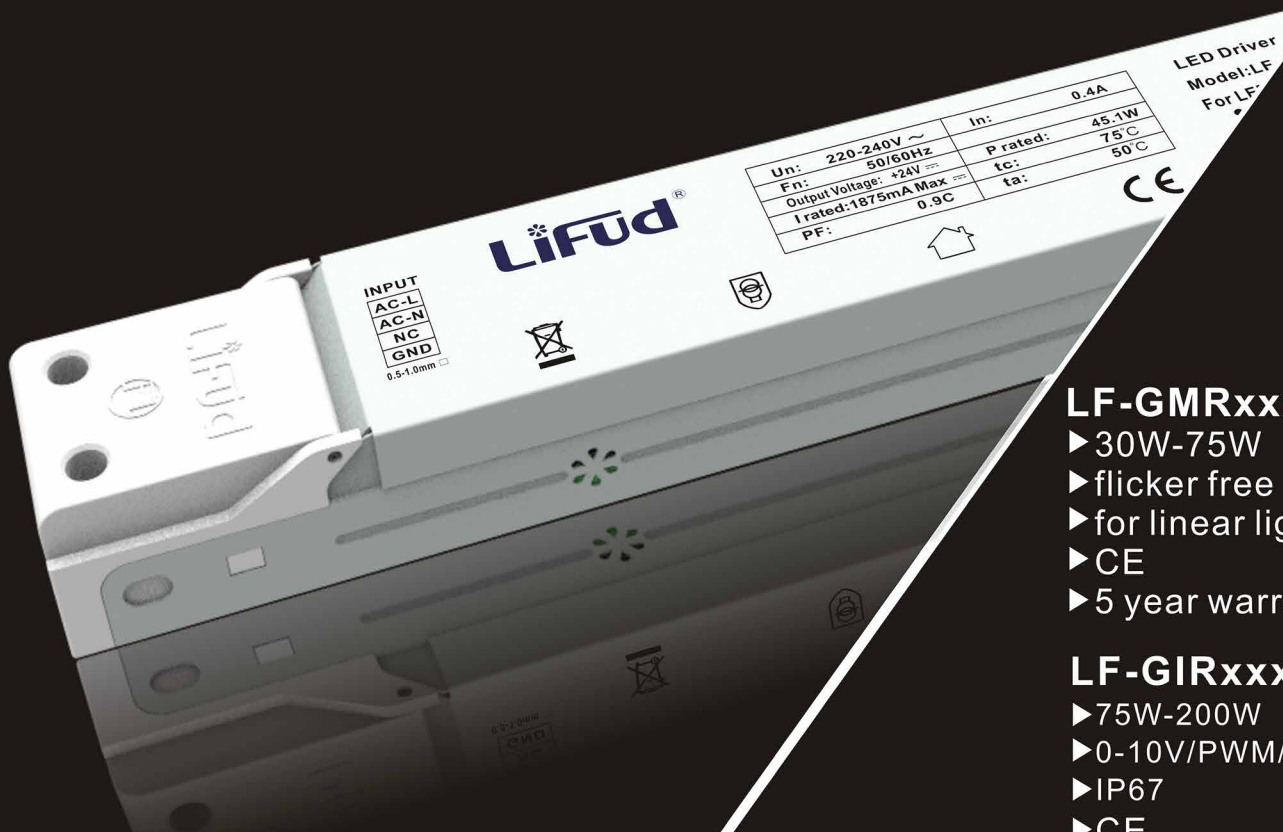

LF-GMRxxxYV

- ▶ 30W-75W
- ▶ flicker free
- ▶ for linear light
- ▶ CE
- ▶ 5 year warranty

LF-GIRxxxYV

- ▶ 75W-200W
- ▶ 0-10V/PWM/Rx Dim
- ▶ IP67
- ▶ CE
- ▶ 5 year warranty

**DC24V
Constant Voltage
LED Driver**



Hong Kong Int'l Lighting Fair
Date: 27-30th Oct.
Booth #1C-D27 & #3CON-064

MATELEC 2018
Date: 13-16th Nov.
Booth #2C12EXT

sales@lifud.com
www.lifud.com

The original XP-G2 has, since its introduction, served as a preferred choice by manufacturers that require superior output, efficacy and optical control. The new XP-G2 HE extends this legacy with a drop-in upgrade for existing XP-G2 LED systems, allowing designers to quickly implement Cree's newest Dmax™ high-power LED chip technology while maintaining the excellent color quality and optical control demanded by applications, such as outdoor, indoor, architectural and portable.

The XP-G2 HE LED leverages Cree's latest chip technology to deliver 25 percent greater output via a higher maximum current of 2000 mA, plus up to 9 percent higher efficacy and lower thermal resistance. ■

OMC's High Brightness Purple LED for Greater Design Flexibility

OMC has launched a new high brightness purple surface-mount LED lamp featuring the company's proprietary Active Diffuser Technology™, which produces a far richer and more efficient output than traditional single-wavelength devices. The vibrant output and ease of driving of the new purple LED SMD lamp makes it ideal for applications such as backlighting, mood-lighting, displays and status indication on items such as front panels and keypads, as well as signaling and industrial electronics. Designated LPRM3268X3, this new SMD lamp requires very low current, has a compact footprint of only 3.2 mm by 2.8 mm, and a depth of 1.9 mm, with the industry-standard PLCC package.

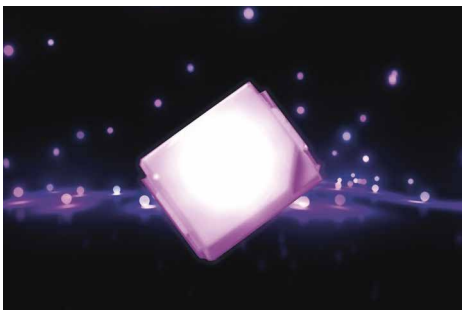

OMC's new high brightness purple LED offers easy to drive Active Diffuser Technology™; compact footprint; suits backlighting, displays, status indication, signaling, mood lighting and more

OMC's Active Diffuser Technology combines a blue LED chip with colored phosphor-based diffuser media in order to manipulate

the light wavelength and give the desired output spectrum. The device efficiency is comparable to blue gallium nitride-based LEDs, which allows other colors to be produced at higher efficiencies than typically achieved when using different chip technologies. As the output consists of a wide spread of light wavelengths rather than a narrow peak, the result is a more intense, richer color than traditional LEDs. Another benefit of active diffuser technology is that it delivers a more homogenous output, eliminating the wire-bond and lead-frame shadows commonly seen in the beam pattern of standard LEDs.

Applying this approach to generate purple light greatly simplifies the task of incorporating purple illumination into a design. Previously, the most common approaches to generating purple light from an LED was to mix red and blue light from a multichip device, which adds complexity and cost to a design and requires more sophisticated drive circuitry. As the LPRM3268X3 device contains only a single LED chip, it can be used in the same circuit layout as other standard LED colors, simplifying designs. Other approaches to generating purple light with LEDs involve the use of a 400 nm LED chip, which is typically less efficient and incorporates a significant UV component to the output, which can give rise to its own considerations.

OMC's Commercial Director, William Heath comments: "Our high output color LED range with Active Diffuser Technology is a newer, more efficient approach to producing colored LEDs. The addition of a rich purple LED to the line-up broadens the color choice available to designers and is certain to help enhance product appearance." ■

LG Innotek - Full Lineup of Horticulture LEDs

LG Innotek announced that it set up a full lineup of "horticulture LEDs," which are the light sources that can make plants grow faster than under the sunlight, and will venture into the global market. LG Innotek secured 30 types of horticulture LED packages optimized according to light wavelength and power consumption. In addition to visible light LEDs, the company also launched horticulture UV (ultraviolet) LEDs.

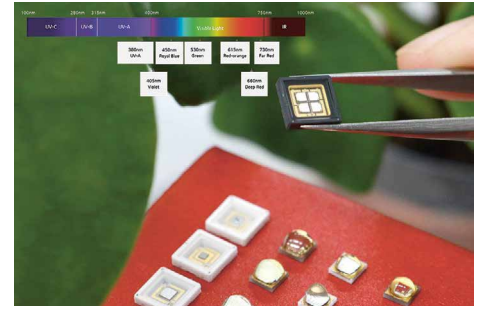

LG Innotek's horticulture LED lineup covers a broad range of the light spectrum

Horticulture LED is a state-of-the-art light source that can control plant growth rate and increase the nutrient content of the crop by using the light of a specific wavelength. This product was developed considering the characteristics that the physiological responses such as photosynthesis and flowering vary depending on the wavelength of light.

In addition, LG Innotek's horticulture LEDs can raise the marketability of the crops. LG Innotek's 380 nm wavelength UV-A LED can be used to enhance the phytochemical content of antioxidants such as anthocyanin and lutein. 405 nm wavelength LEDs that emit purple light can thicken the leaves of the plant and make the color sharper.

The company's horticulture LEDs can be applied to smart greenhouses and plant factories to boost productivity. 450 nm wavelength LEDs that emit blue light and 660 nm wavelength LEDs that emit dark red light can shorten the growth period of plants by promoting photosynthesis regardless of environmental changes such as the weather.

LG Innotek's horticulture LED is good for eco-friendly organic farming. The 530 nm LED light has the function of suppressing mold development. Also, pests do not like 615 nm light wavelength. So, a 615 nm wavelength LED can drive away nasty pests.

In particular, the company plans to provide horticulture LEDs that are optimized according to crop type, lighting location, and required functions. This is possible because the company has more than 30 products with different wavelengths, light quantity and irradiation angle..

LG Innotek plans to launch an additional 730 nm near infrared LED this year. This product can increase the content of specific ingredients, such as sugar in crops and saponin in ginseng, and can be utilized for cultivation of functional crops. ■

Tridonic Introduces Improved, New Gen. of LED Modules

The fifth generation of the 24 mm LLE ADVANCED modules for linear luminaires and panel lights feature an impressively high efficacy of up to 200 lumen per watt as well as superior quality. Luminaire manufacturers and OEMs will also benefit from greater flexibility, thanks to the wider variety of products.



Tridonic's generation 5 LLE modules feature upgraded efficacy and quality

With the fifth generation of the 24 mm LLE ADVANCED modules, Tridonic sets new standards in terms of the efficacy and quality of linear LED modules. This is down to a rigorous procurement and production process in which only premium raw materials are used. In addition, chip selection is based on strict optical criteria as well as comprehensive tests, which far exceed the requirements of the usual standards. The efficacy of the LLE ADV5 modules has thus been boosted to 200 lumen per watt in the high-efficacy portfolio and to 190 lumen per watt in the standard portfolio.

Greater efficacy with a CRI > 90 and more flexible use:

The efficacy of modules with a high color-rendering index (CRI) > 90 has been improved even further compared to the previous version. All modules are available with a CRI > 80 and a CRI > 90, both as SELV and non-SELV variants. There is even greater flexibility when using the modules

now that it is also possible to combine SELV variants in different lengths, with the light remaining completely homogeneous. Lengths and drill holes according to ZHAGA requirements also allow the modules to be easily integrated into existing designs.

Wide range of applications:

The new LLE modules are compatible with existing accessories for linear luminaires, such as ACL linear lenses with various beam characteristics, mounting clips, end caps and covers. With the appropriate covers, they can even be used straight away as luminaires. When combined with the appropriate LED driver (fixed output or dimmable version), a highly efficient system is created for a wide range of applications. The LLE modules are available in different lengths and with color temperatures of 2,700 K, 3,000 K, 3,500 K, 4,000 K, 5,000 K and 6,500 K, whereby the respective color temperature remains constant even when dimmed. The modules have a service life of 72,000 hours and come with a five-year manufacturer guarantee. ■



Beyond Your Imagination

we provide better service, and you design extraordinary luminaires

HE & HM Series

Power consumption from 3W to 355W
High CRI and high efficiency

HC Series

Saturated color helps people redefine colors they used to see
 $R_f = 95$, $R_g = 105$ & $R_1 \sim R_{15} > 90$

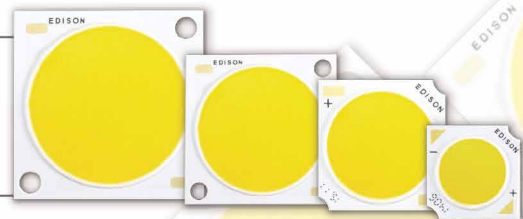

EdiPower Series

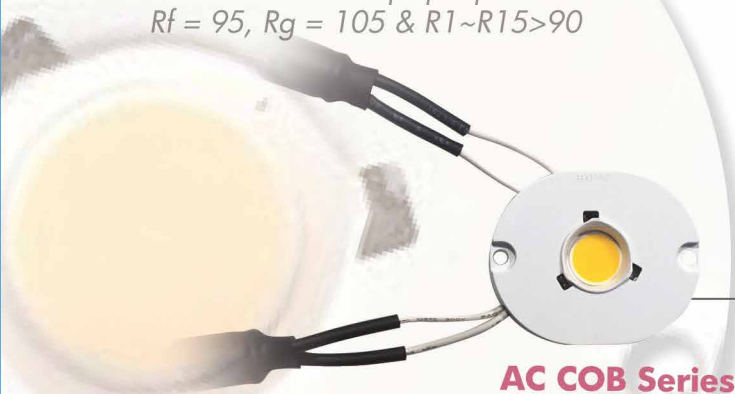

AC COB Series

Low Percent Flickers Series

Percent Flicker < 30%
Triac dimming



Hong Kong International Lighting Fair (2018.10.27-30)
Hong Kong Convention and Exhibition Center
Booth No. 5C-D02 in Hall 5



Find out the information now!
www.edison-opto.com
service@edison-opto.com.tw



Copyright©2018 Edison Opto Corp. All rights reserved.

Fulham - Low-Profile LinearHO High Output LED DC Modules

Fulham Co., Inc., a leading supplier of lighting components and electronics for commercial and specialty applications, is now shipping new low-profile versions of its popular LinearHO LED Modules. The new LP-LinearHO high-output DC LED modules are available in eight configurations and are ideal for linear highbays or linear strip luminaires, for example, four- or eight-foot vapor tight and troffers.



Fulham's new LP LinearHO DC LED Modules are available in 5.5 to 58-inch models and are designed for Highbay, Vapor Tight, and Troffer Luminaires using FLUO T5HO lamps

For maximum versatility, the LP-LinearHO DC LED modules are offered in six standard models:

- 5.5 inches with 1,959 lm (480 mA),
- 11 inches with 3,919 lm (640 mA),
- 22 inches with 4,899 lm (800 mA)
- 22 inches with 7,700 lm (1250 mA),
- 44 inches with 8,656 lm (1400 mA),
- 44 inches with 14,699 lm (2400 mA).

A 46-inch model with 8,656 lm (1400 mA) and a 58-inch version with 14,699 lm (2400 mA) are available as custom orders.

The LP-LinearHO DC LED Modules are high-lumen units with an output range from 14,699 lm down to 219 lm, delivering higher lumens per watt and higher thermal conductivity. LP-LinearHO DC LED Modules allow for OEMs to meet the DLC Premium requirement much easier and with greater flexibility. What makes these different from Fulham's standard LinearHO units is their lower profile, both in width (1.26 inches) and height (.29 inches), higher thermal performance, and 8 percent higher lumen output. The LP-LinearHO DC LED modules are easier and faster to install when compared to standard DC modules. The LP-LinearHO is rigid and has self-thermal management; the MCPCB is

mounted in an aluminum extrusion to eliminate the need for heatsinking. They are also suitable for dry or damp locations.

All the LP-LinearHO units are compatible with Fulham programmable drivers as well as Fulham's HotSpot LED emergency lighting systems.

A Snap-On, diffused lens accessory as well as a 2 or 4 module harness is available for all the LP-Linear DC LED Modules. The units also are cURus certified, CE listed, and RoHS compliant. ■

Conext - Electrical Contacting without Connectors and Tools

With the Conext system, the LED specialist Lumitronix from Baden-Württemberg has succeeded in connecting LED modules with no additional aids. The patented development ensures that the merging of LED modules runs smoothly and quickly. The puzzle-like connecting elements allow both mechanical connection and electrical contacting without any further tools. No soldering, no cables, no plugs! The connectorless assembly of the modules is made possible by the fact that both the noses of the male modules and the grooves of the female modules have electrical contacts that conduct the current reliably and constantly.



Conext modules are only available from LUMITRONIX®. The three different product families, ConextMatrix, ConextPlay & ConextBar, are suitable for a wide range of applications

The Conext connection and contacting system from Lumitronix is currently used in three product families:

- ConextMatrix
- ConextPlay
- ConextBar

ConextMatrix - for flexible shapes and large surfaces:

The ConextMatrix LED modules, which are available in 5 different shapes (edge modules, corner modules, center modules, linear modules and power supply modules), set almost no limits to the creative development of large-area light fields. Up to 270 ConextMatrix modules can be supplied simultaneously via one power connection on the power supply module. Each module is equipped with 4 powerful Nichia LEDs with a CRI value of over 90.

ConextPlay - creative playing with forms and colors:

The modules of the ConextPlay family follow a playful and creative approach, which are available in three forms (connection module, female-module, male-module). Each module is available with a high-power LED of the Nichia 757 series in one of the colors red, green, blue and warm white. 150 modules can be operated via one USB-C connection. The ConextPlay modules can be used for backlighting or in model making. Another area of application is playful learning and experimentation.

ConextBar - LED strips with variable length:

With the ConextBar, 10 mm wide LED strips in various module lengths can easily be realized. The short ConextBar4 LED modules with 4 LEDs extend the strips by 20.7 mm, and the long ConextBar20 LED modules with 20 LEDs by 104 mm, creating a great deal of flexibility. The power is supplied by a power supply module, which is available as male and female-version. Up to 50 ConextBar20 LED modules or 250 ConextBar4 LED modules can be operated simultaneously. The modules are equipped with warm white LEDs of the Nichia 757 series that convince with a good efficiency and a CRI value of over 90.

"The Conext modules lie flat and do not require any superstructures," explains Christian Hoffmann, CEO of the Hechingen-based company. "The modules are joined together without connectors because both the noses of the male modules and the notches of the female modules possess electrical contacts that reliably conduct the current. The different module shapes in a puzzle look, also enable the creation of individual light fields in many shapes. This is unique worldwide and only available from LUMITRONIX®." ■

Starring CAS 140D!



See us at
LpS 2018
Booth A13

Accredited Color Quality

- ▲ Instrument Systems test laboratories accredited to ISO 11664 for colorimetric quantities **NEW**
- ▲ Highly accurate measurement of correlated color temperature (CCT) and color rendering index (CRI)
- ▲ Traceable measurement uncertainties of chromaticity coordinates only ± 0.0015

www.instrumentsystems.com/CAS140D

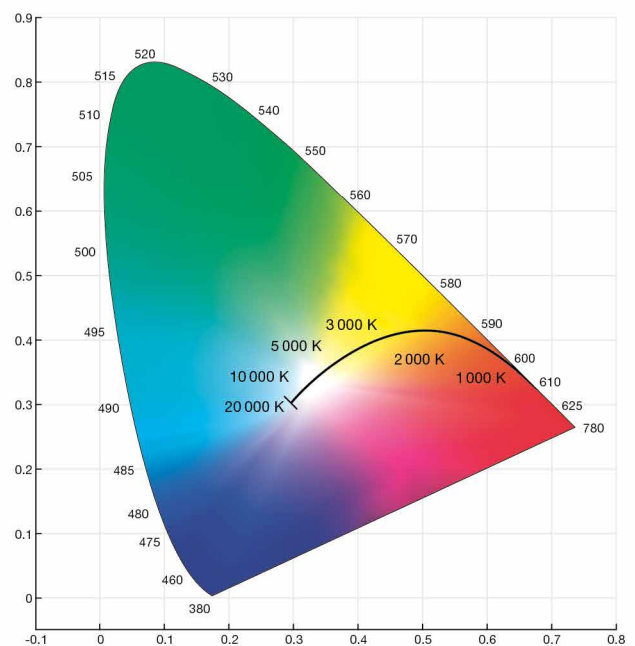

We bring quality to light.

Tivoli's TivoTape™ Boosts Design Opportunities

Without a doubt, LED Tape Light has become a staple in most Lighting Designers creative palettes. In regards to Low Voltage LED Tape Light, there is a distinct difference between maximum load lengths to maintain Class II listed status and the maximum run lengths before experiencing significant voltage drop, which will result in lumen loss. Tivoli has solved that with the design of our proprietary Zero Drop Elite TivoTape™. Most LED Tape uses from 1-3 oz. of copper for the traces. TivoTape™ Elite embodies 4 oz. of copper traces.

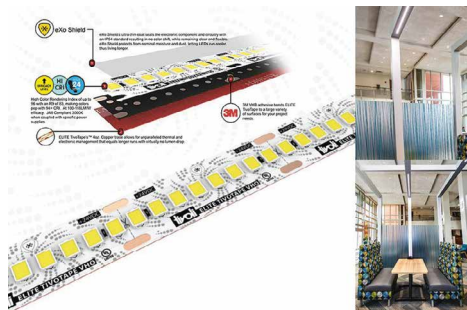

With its brand new Zero Drop Elite TivoTape™, Tivoli just solved a lighting design challenge

Feature and Benefits:

- 4 oz. Copper Trace
- 3 Wattage ratings with the same high density spacing for a variety of run lengths
- 317 to 826 Lumens Per Foot
- CRI 96 | R9 83
- 100 to 119 Lm/W Efficacy
- 1.5 Step McAdam Ellipse
- Title 24 JA8 Compliant (California)
- 2200, 2400, 2700, 3000, 3500, 4000, and 5000 K CCT available
- ExoShield IP54 Coated
- Zero pixilation in most extrusion with milky white and frosted lenses

From a design perspective, the voltage drop by the end of the run of Standard Tape cut to maximum load is significant enough that when a second run is placed in line along with the first, there is a significant visible difference in brightness. When voltage drops, so do lumens toward the end of each maximum electronic run length. In some popular design elements this can result in gradations of intensity in the desired effect.

Elite TivoTape's™ 4 oz. Copper trace allows for unparalleled thermal and electronic management that equals longer runs with virtually no lumen drop. Additionally,

4 oz. traces provide greater durability and thermal management, which can increase the overall systems lifetime.

High CRI is an industry standard request for flexible tape in today's market. Elite TivoTape™ offers a CRI, making colors pop with 94+ CRI. Tight LED spacing of the 2835 diodes produce zero scalping within our narrowest depth profile and a binning tolerance of 1.5 MacAdam Ellipse keeps consistent color throughout your project giving you expected results in quality lighting. ■

LED on a Roll - Tridonic's Flexible IP67 LED Modules

The flexible LLE FLEX IP67 EXCITE continuous row from Tridonic offers protections from dust and water and can be installed in moisture-prone rooms, like bathrooms, without a second thought. A stable color temperature without any chromacity coordinate shift also allows for combination with other continuous rows.



Tridonic's LLE FLEX IP67 EXCITE offers high IP protection combined with high CRI, high efficiency, and narrow 6 mm LED pitch for surprisingly homogeneous light

The dimmable 24 V constant voltage continuous row with 6 mm light point intervals produces impressively homogeneous light. Tridonic avoids chromacity coordinate shift, which would otherwise be typical for such a high degree of protection, by using innovative airGAP technology in the manufacturing process. The IP67 continuous row is especially suitable for applications that call for high lighting quality in addition to a high degree of protection. The color-rendering index in all versions of the LLE FLEX IP67 EXCITE is higher than 90, and module efficiency boasts up to 100 lm/W.

Features and Benefits:

- IP67: protected against water & dust
- Luminous flux range of 600, 1,200 and 1,800 lm/m
- Color temperature 2,700, 3,000 and 4,000 with SDCM 3 (1)
- Module luminous efficacy up to 100 lm/W
- High design freedom due to 5 cm cut-options
- Pitch distance of 6 mm enables high light homogeneity
- Self-adhesive 3M tape at the backside for simple mounting on different surfaces
- All the accessories – from the Interconnector to the Input-terminal till End cap – has been specifically designed for the IP67 tape and allows intuitive and easy handling which still keeps the protection of IP67 active
- Self-cooling (no additional heat sink required)
- Long life-time up to 50,000 hours
- 5-year guarantee
- System solution in combination with Tridonic constant voltage LED Driver

Flexible, safe and easy to handle:

The flexible continuous row is available with a luminous flux of 600, 1,200 or 1,800 lm/m and in color temperatures 2,700, 3,000 and 4,000 K (SDCM 3). The versatility of these options means that the required lighting for different applications can be achieved as needed. The design freedom is almost limitless, as the row can be cut to size in 50 mm increments. The continuous row comes on self-adhesive film and can be mounted on different surfaces.

Connectors, terminals or end caps specially developed for the LLE FLEX make handling and mounting easy and guarantee the high degree of protection during use. Together with manufacturer-specific constant voltage LED drivers (fixed output or dimmable), the result is a reliable system solution with up to 50,000 hours of service life. ■

EPtronics LP Series - Latest Programmable LED Drivers

EPtronics is pleased to announce its latest generation LP Series of programmable constant current LED drivers with flicker free operation. All five wattage families are included in UL's Class P LED Driver Program: LP25W, LP40W, LP50W (T8), LP55WW, and LP96W. This UL program allows LED luminaire manufacturers to quickly substitute existing drivers with pre-approved EPtronics drivers without the need for recertification by UL.



EPtronics' latest constant current LED drivers from the LP Series of programmable offer flicker free operation and UL's Class P certification

LP Series drivers can be pre-programmed to customer requirements during EPtronics manufacturing or re-programmed in the field using EPtronics' EP-PRG-01 USB Interface Programming Tool. In addition, the optional EP-CRADLE-01 programming cradle enables OEMs to reduce SKUs and satisfy customer needs by quickly programming LP Series drivers on their own assembly lines.

EPtronics, a leading manufacturer of solid-state lighting power supplies, offers the broadest selection of UL recognized off-the-shelf and custom LED drivers. Our US-engineered products ensure that you receive exceptional performance and reliability to satisfy all your technical requirements.

All EPtronics products are protected by a standard 5-year limited product warranty. ■

Inventronics - Flicker-Free, Tight Tolerance Dimming LED Drivers

Inventronics releases a new programmable IP20 LED driver series ideal for indoor projects such as panel, troffers, downlights and other fixtures requiring a compact driver and a lower profile. The new LUG-040SxxxDTE is an expansion to the existing low power, indoor programmable LED driver portfolio.



Inventronics' latest LED drivers, the LUG-040SxxxDTE, are UL Class P certified, Class 2 recognized and have a long calculated lifetime of over 100,000 hours @ 80% load and $T_c = 70^\circ\text{C}$

Making LED
Lighting Solutions
Simple™

We Accelerate Time to
Revenue by Providing

- ▶ The Most Comprehensive System-Level Product Portfolio
- ▶ Solid-State Lighting Expertise
- ▶ Design Support Services
- ▶ Global Supply Chain and Business Solutions



FUTURE
Lighting Solutions
www.FutureLightingSolutions.com

Visit us at
Booth A17

ELPEPCB®
peters



Easy thermal management with screen-printable thermal transfer pastes

- highly thermally conductive systems
 - effectively lower operating heat
 - flexible layouts and layer thicknesses are applied by screen printing on the unassembled pcb within pcb production
 - when printing into heat vias, the thermal interface is enlarged and thermal transfer/dissipation improved
 - thermal transfer resistances are reduced
 - cost-effective alternative to conventional heatsinks or heat-conductive foils
- Heatsink Paste (HSP)**
 - for optimum heat transfer and heat dissipation
 - Thermal Interface Paste (TIP)**
 - elastic, thus enabling an optimum connection with metallic cooling elements or housings
 - thermo-mechanical decoupling even with permanent temperature changes

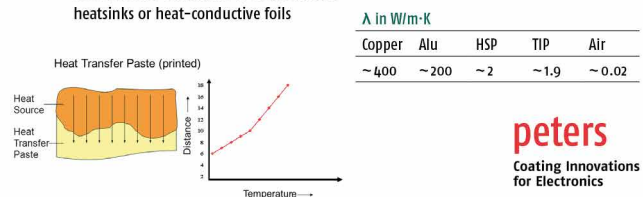

peters
Coating Innovations
for Electronics

Lackwerke Peters GmbH & Co. KG
Hooghe Weg 13, 47906 Kempen, Germany

E-Mail: peters@peters.de
Phone: +49 2152 2009-0

www.peters.de

Designed to offer OEMs complete driver flexibility, they provide full power at almost any output current range from 800-1500 mA from 40 W down to 28 W. With a tight tolerance in the low dimming range, this series offers flicker-free, smooth dimming to 10% giving it a consistent light quality performance.

OEMs benefit from the added convenience of the UL Class P certification, increased competitive advantage, and reduced inventory SKUs. They are also Class 2 recognized which increases safety while reducing materials cost. With a compact form factor and color-coded terminals, the product facilitates safe and easy installation.

The LUG-040SxxxDTE operate over a 90-305/127-250 Vdc input voltage and are approved to UL, FCC, CE and Class P allows it to be used in many countries around the world. They are highly reliable and have a calculated lifetime to be at least 100,000 hours when operating at 80% load with a case temperature of 70°C. Production quantities are available now. ■

Espen Technology Launches 4-Lamp, Type A, Dimmable Driver

Espen Technology announced the expansion of its Type A driver line, to include its new 4-lamp, Type A dimmable driver. The new 4-channel driver is model #VEL60BN-4C-10V. It operates Type A lamps only, and provides 0-10 V dimming.



Espen Technology's RetroFlex driver is a dimmable 4-channel driver for Type A LED lamps replacing fluorescent lamps

According to John Clancy, SVP of Sales & Marketing at Espen, "Espen's 2-lamp, Type A driver has been a very popular item for many years, and customers have requested that we provide a 4-lamp, 4-channel version." Clancy added, "This new 4-lamp driver really completes

our Type A driver line. Espen continues to be a leading provider of LED drivers to the lighting industry."

The new driver can provide either 3-lamp or 4-lamp 190mA output current per channel, and up to 20 watts of power per channel. It has a power factor of 0.96 at 277VAC input voltage and 0.98 PF at 120 VAC input voltage.

The new 4-lamp Type A driver features active power correction, constant output current, and a Class A sound rating.

The driver is UL8750 (damp & dry listed), EN61347 listed, and FCC Class A compliant. Espen protects the driver with a 5 year / 50,000 hour warranty. ■

38 VIN, 10 A Boost μ Module Regulator - Ideal for Driving LEDs

Analog Devices announces the Power by Linear™ LTM8005 boost DC/DC μ Module® (power module) regulator designed for driving LEDs. The LTM8005 includes a DC/DC controller, power switch, Schottky diode and current sense resistor in a 9x11.25x2.22 mm BGA package.



The LTM8005's low profile package enables utilization of unused space on the bottom of PC boards. Its thermally enhanced, compact over-molded Ball Grid Array (BGA) package is suitable for automated assembly by standard surface mount equipment

Features:

- Wide Input Voltage Range: 5 V to 38 V
- 40 V, 10A Internal Power Switch
- 3,000:1 True Color PWM™ Dimming
- Internal 40 V Switch for PWM & Output Disconnect
- Int.Spread Spectrum Frequency Modulation
- Open LED Protection with OpenLED Flag
- Short-Circuit Protection with SortLED Flag
- Input & Output Current Reporting
- 9x11.25x2.22 mm BGA Package

Applications:

- High Power LED, High Voltage LED
- Accurate Current-Limited Voltage Regulators

The LTM8005 operates from a 5 V to 38 V input voltage range and can deliver up to 1.6 A of regulated current at an output voltage of up to 38 V. An Inductor is external, enabling the LTM8005 to easily configure in different operation modes including boost, buck-boost, buck and SEPIC topologies with a coupled inductor.

The high reliability H-grade version guarantees operation from -40°C to 150°C. The wide input voltage range and 150°C operation make this μ Module LED driver ideal for automotive and industrial lighting applications.

The operating frequency is adjustable from 100 kHz to 1 MHz, and built-in spread spectrum frequency modulation improves electromagnetic compatibility performance. Brightness of the LEDs can be controlled by the analog CTRL pin and by PWM dimming with a range up to 3,000:1. The LTM8005 provides safety features such as output disconnect short-circuit protection, open LED protection, programmable input current limit, as well as, input and output current reporting. ■

New High Performance Resonant Controller IC with PFC from Infineon

Infineon Technologies introduces the second-generation ICL5102 resonant controller IC designed specifically for power supply and lighting drivers. Main target applications are LED drivers for professional and industrial lighting, and street lighting.



Infineon's new high performance PFC & resonant controller for LCC and LLC provides a wide input voltage range, high efficiency, high PF and low THD

Features:

- Universal input 70–325 V
- Highest efficiency up to 94% by resonant topology
- THD <3.5%, PF >0.95
- Burst mode, low standby
- Low BOM cost
 - Combo controller IC
 - 500V MOSFETs at LLC stage
 - Low cost resistors to set working points

Benefits:

- Enables global designs
- Can be used from 40-250 W
- Best-in-class PFC and THD at full and light load
- High efficiency: more lumen output and less thermal load
- No components required to match the PFC and LLC stage
- Protection and auto restart

Target Applications:

- LED lighting
- Professional lighting
- Street lighting/Smart street lamp

The ICL5102 integrates Power Factor Correction (PFC) and half-bridge (HB) controllers in a single DSO-16 package. It supports universal input voltages ranging from 70 V AC to 325 V AC, and has a comparable wide output range. A low number of external components are required to configure and support this controller IC. All parameters are set by resistors.

The ICL5012 supports fast startup under 500 ms at less than 100 μ A. The industry-leading PFC is greater than 99 percent and Total Harmonic Distortion (THD) is less than 3.5 percent. The controller has up to 94 percent efficiency by resonant topology. The active burst mode for low standby consumes less than 300 mW. An enable/disable function supports dimming.

The PFC controller features brownout detection, adjustable THD for light load operation, and high power factor correction. Due to the high accuracy of BUS voltage sensing, only four PINs are required for PFC action. The resonant HB controller has a fully integrated 650 V high-side driver using an

internal coreless transformer with self-adaptive dead time ranging between 250 ns and 750 ns, and an operating frequency up to 500 kHz. It can detect overload, short circuit, BUS, HB or output under and over voltage as well as over temperature. An integrated capacitive mode regulator prevents operation in capacitive mode. All protection features use AUTO restart (No Latch). ■

Helvar Launches LOOP SELV60 LED Driver Series

Helvar is proud to present LOOP: Helvar's first looping mechanics for LED drivers. LOOP is a combination of an SELV60 LED driver with terminals, integrated strain reliefs and, in DALI drivers, additional control terminals for fast and accurate wiring. These new mechanics are optimized for independent usage applications where safe and stable installation is needed.

Size matters.



New Mini Types

regular - trailing edge - DALI - 1-10V



LOOP is Helvar's first driver that allows cabling without any tools

The drivers enable looping of mains and DALI wires with doubled input terminals throughout the driver, saving time and effort on a site's actual wiring work. Bigger looping connectors allow quick cable connections, and also support a variety of wire thicknesses. Wires are secured to the driver with click-on cable clamps, and the strain-relief cover clicks on effortlessly, securing connections without any need for screws. Installation on site is faster since not a single screw or tool is required—wires are secure in their robust, sturdy housing. Drivers with LOOP mechanics are ideal for independent use with Class I, II and III SELV60 rated luminaires. ■

Analog Devices - 60 VOUT Synchronous Boost LED Driver

Analog Devices announces the Power by Linear™ LT3762, a 60 V output, high efficiency, synchronous, boost LED driver controller with a programmable internal LED PWM signal generator and spread spectrum frequency modulation that yield low EMI noise. The versatile LT3762 includes a rail-to-rail current sense amplifier, enabling high side or low side current sensing that in addition to synchronous boost facilitates synchronous buck-mode and buck-boost mode topologies and nonsynchronous SEPIC designs.

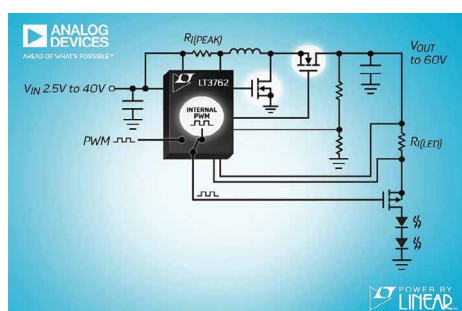

Analog Devices new LT3762 provides 60 V output voltage at low EMI, while also maintaining low quiescent current and shutdown current

The LT3762's 2.5 V to 38.5 V input voltage range and synchronous operation is ideal for automotive power systems, portable instruments, industrial applications, medical instruments and architectural lighting. An auxiliary on-chip buck-boost converter provides the necessary gate drive voltage in low voltage systems, and when combined with a low 500 μ A maximum quiescent current and 1 μ A shutdown current ($T_A = 25^\circ\text{C}$), results in high efficiency over wide input voltage and output current ranges.

Features:

- Synchronous Controller for Highest Efficiency
- 500 μ A Maximum Quiescent Current and 1 μ A Shutdown Current ($T_A = 25^\circ\text{C}$)
- Optional Spread Spectrum Frequency Modulation for Low EMI
- Internal 250:1 PWM Signal Generator

In systems where EMI is a concern, the LT3762's optional spread spectrum frequency modulation can be enabled to reduce the effective switching frequency noise. An on-chip PWM signal generator is synchronized to the internal oscillator for lowest noise performance. Internal PWM generation provides 250:1 dimming; external 3000:1 dimming or analog dimming can also be employed. Other features of the constant current and constant voltage LT3762 include current mode operation with cycle-by-cycle current limiting, adjustable 100 kHz to 1 MHz switching, programmable undervoltage lockout, open LED and short-circuit protection with fault status indicators, LED overcurrent protection and thermal shutdown.

The LT3762 is available in thermally enhanced 28-lead TSSOP and 4x5 mm QFN packages. Three temperature grades are available, with operation from -40°C to 125°C (junction) for the extended and industrial grades, and a high temperature grade of -40°C to 150°C . ■

GlacialTech Announces New Igloo SS250 LED Flood Light SKD Kit

GlacialTech, the diversified LED technology provider, announces a new 250 W heatsink for outdoor flood light and available for single CoB or Multi-chip LEDs. The Igloo SS250 features an efficient heatsink with thermal resistance 0.235°C/W for Multi-chip LEDs

and 0.263°C/W for single CoB. The Igloo SS250 with heat pipes design for single CoB to enhance the heat dissipation quickly.



GlacialTech's Igloo SS250 SDK Kit allows for fixtures that are dustproof and waterproof against extreme weather and strong jets of water

Features:

- Rated for 250 to 280 W single CoB or Multi-chip LEDs
- Thermal resistance 0.263°C/W for single CoB and 0.235°C/W for Multi-chip LEDs
- Adjustable stainless steel mounting bracket and screws
- IP65 rated, suitable for outdoor applications

GlacialTech's experience in thermal design allows the Igloo SS250 to create a heatsink boasting an excellent thermal resistance using stamping technology. The efficient thermal performance makes high output single CoB or Multi-chip LEDs up to 280 W can be accommodated. Customers can easily use the Igloo SS250 to construct high wattage LED flood lights and make sure the LED will not be overheated and therefore have a long lifespan.

The Igloo SS250 thermal module is available as a standalone, or as a semi-knockdown (SKD) kit that includes heatsink module, adjustable stainless steel mounting bracket and screws. It also offers the waterproof bridging connector that can easily install the power cables between LEDs and drivers. The SKD kit allows use in high output lighting for stadiums, parking lots, and outdoor storage areas.

With an IP65 rugged design, LED floodlights built with the Igloo SS250 SKD kit are dustproof and waterproof against extreme weather and strong jets of water. Fixture designers can choose the appropriate LED module and driver for their lighting needs and easily create high performance outdoor application with dependable GlacialTech thermal technology. ■

More Accurate, Faster, Further - Instrument Systems' DSP 200

Instrument Systems' new, versatile photometer, the DSP 200, conforms to the highest accuracy grade L to DIN 5032-7 (2017) and has an extremely broad measuring range from 0.1 mlx to 200 klx for all common light sources, including pulse-width modulated LEDs. It is extremely well suited to ultra-fast measurements of spatial light distributions.



Instrument Systems' newly developed DSP 200 photometer in the highest accuracy class L performs ultra-fast measurements of spatial light distribution from 0.1 mlx to 200 klx

The newly-developed DSP 200 photometer uses a silicon photovoltaic cell as a detector that achieves outstanding stability and the highest degree of accuracy due to integrated innovative cooling to 0°C. The silicon photodiode is precisely adjusted to V (λ) and has a light-sensitive surface of only 6 x 6 mm. This ensures an excellent local resolution that pays off, in particular with light sources with sharp gradients and new applications such as glare-free headlights, pixel headlights and scans due to the cut-off line.

In addition to traditional light sources, test specimens with pulse-width modulated LEDs or LED modules can also be measured thanks to the unique combination of high-precision analog technology and advanced digital signal processing. The measured signal passes through a digital, auto-adaptive filter that automatically detects and eliminates possible modulations and interferences. The filter characteristics are optimally adjusted in a continuous monitoring process.

The most common use of the DSP 200 is goniometric raster measurements 'on-the-fly'. The fast internal sampling rate enables light distributions of pulse-width modulated light sources with a wide range of pulse frequencies to be accurately measured, even with extremely short switch-on cycles. The high data transmission rate enables the measurement of even high-resolution rasters in the shortest of times.

Instrument Systems offers extensive software for a wide range of applications. The LightCon software was specially developed for fast measurement of external automotive lighting and light sources with comparable requirements, such as airfield lighting or variable message signs and retro reflectors. The SpecWinPro software is tailored to spectral analyses in the areas of solid-state lighting and general lighting. It supports the measurement of spatial radiation properties of lamps, luminaires and modules, as well as the control and measurement of electrical operating data. ■

elt INNOVATION
IN LIGHTING
TECHNOLOGY



U-pulse

- Individual or group control over lighting fixtures
- Circadian rhythm synchronized lighting

FEEL THE REAL POWER OF LIGHT

Create lighting scenes, light sequences, control colour temperature and adjust lighting intensity



BLE Driver

BLUETOOTH & DALI DIMMABLE
control gears up to 45W

eSMART TUNABLE WHITE ORC < 5%

HUMAN
CENTRIC
LIGHTING



Pro version

- Configure and control
- Alarm and event programming
- Real-time monitoring
- Cost and energy consumption calculation reports

Combined Conformal Coating and Automated Inspection System

Nordson ASYMTEK announces an automated coating inspection (ACI) line combining its Select Coat® SL-940 Conformal Coating system with the FX-940UV Series ACI/AOI Automated Conformal Coat Inspection system. Together, the systems ensure a conformal coating process that's accurate and reliable, and delivers ongoing coating quality and consistency.



The combination of conformal coating and inspection ensures an accurate and reliable coating process

Eliminating coating problems starts with a high-quality conformal coating system with process controls. The Nordson ASYMTEK Select Coat SL-940 conformal coating system provides the highest quality and productivity for automated coating processes. The system has a wide range of features to monitor and control the process and to provide traceability, such as Fan Width Control, Viscosity Control, Flow Monitoring, a bar code system, and a vision system. Information can be exchanged with customer-specific Factory Information Systems (FIS) and Manufacturing Execution Systems (MES) to ensure factory production workflow.

Conformal coatings used by electronic manufacturers contain UV indicators for the purpose of inspection. Since coatings are transparent, parts must be viewed under ultraviolet or black light to verify coverage and non-coverage. The FX-940UV's advanced, high-power UV lighting and newly available image-processing technology integrate several techniques, including coverage and color inspection, normalized correlation, and rule-based algorithms to provide complete inspection coverage with an unmatched low false-failure rate. Advanced multiple-camera imaging technology offers high-speed inspection with defect coverage. The FX-942 model provides dual-sided viewing (top-down and

bottom-up) cameras. The ACI/AOI systems inspect conformal coating coverage and verify correct part assembly in SMT or through-hole applications, improving quality and yield.

With minimal programming, the inspection set-up is fast and intuitive, typically requiring less than 30 minutes. Automated inspection typically takes only a few seconds and results are immediately displayed. These results can be stored and reviewed off-line. The FX-940UV also reads all common barcodes and captures board images for product traceability.

Configurable for several line positions, the FX-940UV ACI series is equally effective for coating, pre- and post-cure, and final assembly inspection. Off-line programming maximizes machine utilization and real-time SPC monitoring provides a valuable yield enhancement solution. The FX-940UV can be fully integrated with a FIS/MES system to capture up-to-the-minute process data. Single-page, quick feedback reports provide an overall view of the inspected board and allow you to zoom in on specific areas of interest, such as around keep out zones.

Together, Nordson ASYMTEK's Select Coat® SL-940 conformal coating system and FX-940 ACI can team up for coating that is done accurately and reliably. ■

Kyocera -World's First Full-Spectrum LED Aquarium Lighting

Kyocera Corporation announced that the company developed the world's first full-spectrum LED lighting for aquariums. Kyocera's high-color-rendering LED lighting combines its proprietary violet LEDs and RGB (red, green and blue) phosphors to create lights close to natural sunlight at specific underwater depths.

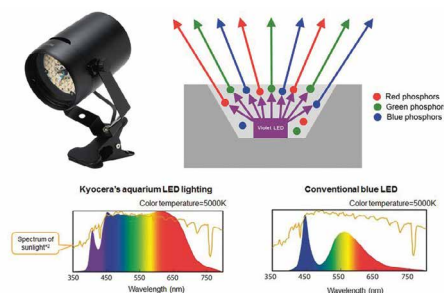

Kyocera's aquarium LED lighting is designed to optimize growth of corals and marine plants

Kyocera's new LED lighting is ideal for growing various water creatures as it reproduces the light close to the natural habitats of corals and water plants. The optical spectrum can also be customized to reproduce the deep blue color for ornamental purposes

Kyocera's aquarium LED lighting will be available to the Japanese market in the middle of August in four types:

- Marine Blue reproducing spectrum of sunlight at 2.5 m below sea level
- Aqua Blue reproducing spectrum of sunlight at 11 m below sea level
- Natural White reproducing similar spectrum of sunlight above ground
- Deep Blue for ornamental purposes

Specifications:

Weight:	1,400 g (lamp), 900 g (light source)
Dimensions:	Diameter: 107 mm (body) Depth: 145 mm (body) Width: 110 mm (clip)
Input voltage:	AC100 V (50/60 Hz)
Power:	51.2 W

Product Features:

Lamps emitting light mimicking natural sunlight helps grow coral and water plants. By combining violet LEDs and RGB phosphor blending technology, Kyocera's high-color-rendering LEDs produce light extremely close to natural sunlight. By customizing the spectrum, it reproduces the light close to that of the natural habitats of corals and water plants at specific underwater depths.

Furthermore, as each LED element emits full-spectrum light close to natural sunlight, it produces light with luminance uniformity without color separation making it ideal for growing corals and other sea creatures for a long period of time.

High Light Output:

Kyocera's proprietary ceramic technology provides excellent durability in an LED light. In addition, an air-cooling function utilizing air convection offers a high output while maintaining high color rendering. Assuming this light would be used near the sea, Kyocera developed a robust design with a heat dissipation structure to use natural air. As this design does not require a fan, which was traditionally considered one of the main reasons for product breakdown, the new aquarium LED light can minimize failures. ■

Lighting Science Group Introduces Good Day&Night Downlight

Lighting Science® announced the release of a new daytime productivity and natural sleep cycle lighting solution. The Good Day&Night® Downlight combines the company's popular, patented GoodDay® and GoodNight® LED spectrum technologies into a single, easy-to-use luminaire.



Lighting Science Group's new LED luminaire, Good Day&Night® Downlight, delivers optimal daytime productivity and natural sleep enhancement in one solution

The new downlight is a comprehensive solution that enables residential and commercial customers to optimize daytime alertness, while also enhancing their nighttime sleep environment.

Based on technology developed in collaboration with NASA to support the natural circadian rhythms of astronauts living onboard on the International Space Station, the Good Day&Night solution enables users to easily change between focus-enhancing and sleep-enhancing spectrums. The luminaire is controlled via a standard wall switch, or by a wireless switch accessory. Mounting kits are available for retrofit and new construction, providing living spaces with energy-efficient, circadian lighting for both day and night in any area of your home or workplace in a sleek, functional design.

"The new Good Day&Night Downlight delivers on the company's promise to engineer lighting solutions that provide peak visual performance and biological benefits,"

Khim Lee, President, Lighting Science said. "Our human-centric lighting portfolio is leading the global shift in how lighting is applied in residential and commercial applications – our new products are at the forefront of the circadian lighting revolution."

The first commercial installation of the Good Day&Night Downlight will be in New York City at Manhattan's new luxury condominium development, Gramercy Square. Partnering with MNDFL, New York City's premier mediation studio, the team worked collaboratively to create special wellness-focused amenity spaces. The downlight will be installed in the meditation room, and in several shared areas, offering residents healthy, biologically balanced light.

"At Gramercy Square, integrated wellness is supported through a multi-dimensional approach," David Bistricher of Clipper Equity said. "The partnership with Lighting Science naturally aligns with our mission to contribute living innovation inspired by nature, connectivity and a healthy environment." ■

We have squared the (integrating) sphere



FluxGage™

Measures Flux, Color & Flicker of LED Luminaires

- › Designed for testing in production
- › 3x smaller than equivalent sphere
- › Fast, simple and easy to use
- › Cost effective, allows multiple units

LpS 2018

LED SYMPOSIUM
professionals + EXPO

Visit us in Bregenz
booth A1, A3!



mks | **ophir**

<http://www.ophiropt.com/led>

See for yourself - Call for a demo.

+ 49 6151 708-0 or toll free 00800 67447678

Ophir Spiricon Europe, Your Local Sales and Service Center.

Electron Beam Patterning for Full-Color HR OLED Displays

OLED microdisplays are increasingly establishing themselves in consumer-ready wearables and data glasses. In order to meet the requirements for higher efficiency, higher contrast, and higher resolutions in these applications, Fraunhofer FEP scientists have developed a new micropatterning approach for OLEDs on silicon substrates. This might eliminate the use of color filters and shadow masks in the future and allow full-color displays to be developed by means of a new process. An increase in efficiency and considerably broader color gamut has already been demonstrated in first experiments.

The average smartphone user looks at a display about 88 times a day, not counting viewing smaller smart watches or other displays. Displays of all kinds have become ubiquitous and will soon be irreplaceable in everyday life.

If you turn your attention to the world of OLED microdisplays, you will quickly find yourself immersed in data glasses for current and future Virtual Reality (VR) and Augmented Reality (AR) applications, the core of which is the microdisplay. Since the Pokémon Go mania everyone has an idea of what AR means – additional interactive information is being interwoven into the real world. In addition to industrial use in Production 4.0 programs and products, its use in medical technology and in electronic entertainment, AR and VR applications have also been established for years in advertising and the education sector. The days of bulky audio guides in museums could soon be over, not only as a result of previous solutions like tablets and smartphones. Lightweight head-up displays can turn exhibitions into great learning worlds by integrating film scenes, audio, and interaction with the visitor to make a museum experience more memorable.

Thanks to the shallow overall depth that results from the self-luminous properties of OLEDs and their excellent contrast ratios, manufacturers are increasingly turning to OLED microdisplays for AR/VR glasses. Fraunhofer FEP has been continuously immersed in the advanced development of this technology for several years. Nevertheless, there are still some technological challenges that need to be



Probe station with patterned OLEDs in the clean room of Fraunhofer FEP (Credits: ©Fraunhofer FEP)

mastered in order to exploit the full potential of OLED technology for use in consumer-ready data glasses and other AR/VR applications. Very high brightness and efficiency, good yields for large chip areas, curved surfaces, integrated eye tracking, and transparent substrates are some of the tasks still on the researchers' agenda.

Currently, OLED technology faces the hurdle that full-color displays can only be realized by using color filters or shadow masks, which limit OLED efficiency and resolution. Researchers are working intensely on new approaches to fabricate microdisplays characterized by high resolution while at the same time offering high efficiency and long operating lifetime. The patterning of the organic layers of OLEDs is one of the greatest challenges, since conventional methods such as photolithography cannot be utilized with organic semiconductor materials. The use of electron beam technology for microstructuring was successfully demonstrated at the Fraunhofer FEP two years ago. Using its patented process, FEP was able to modify the emission of an OLED through the existing encapsulation layer to create any feature imaginable and even produce high-resolution grayscale images.

Further development of the electron beam process has now achieved full-color OLED without using color filters or shadow masks. To create red, green, and blue pixels, an organic layer of the OLED itself is ablated by a thermal electron beam process. This patterning causes a change to the thickness of the layer stack, which makes the emission of different colors possible. This is the first major step towards the development of full-color displays without the use of restrictive color filters in the process. Elisabeth Bodenstein, developer in the Fraunhofer FEP project team, explains the advantages: "With our electron-beam process it is possible to thermally structure even these sensitive organic materials without damaging the underlying layer."

The results were obtained by simulating and initially estimating the HTL (hole transport layer) thicknesses that are produced by the electron beam. The researchers actually achieved the decoupling of red, green, and blue emissions from the white OLED. Following proof of concept at Fraunhofer FEP, these colors were demonstrated on the first test substrates, exhibiting comparable OLED performance.

In addition to using this new process for OLEDs, electron beam processing can also be used for other applications in organic electronics and inorganic layers. Moreover, the electron-beam patterning process is very adaptable and can also be employed in the areas of photovoltaics, MEMS, and thin-film technology.

Now Fraunhofer FEP scientists are approaching the next milestones, having completed the promising preparatory work. The main goal in the coming years is to use this new method in jointly developing fabrication of OLED microdisplays with partners and establish it in the industry through licensing. To do this, the features will be further miniaturized and the process optimized by working together with interested partners from industry.

The next step planned is to integrate the micropatterning into existing processes in order to gain further know-how jointly with industrial partners. This should enable future transfer of the test results into an existing process line to be worked out in

order to facilitate establishing the technology at the industrial level at a later date.

In parallel, the scientists are also planning an enhanced simulation of OLEDs. The OLED color spectrum will be broadened by suitably modifying the materials and layer thicknesses. In this way, the prospective incorporation the displays in data glasses for special applications such as in industrial manufacturing and medicine should be opened up with the new process. ■

References:

Paper No. L_10_1003: Electron Beam Patterning for Realization of RGB Microcavity OLEDs

Authors:

Elisabeth Bodenstein, Matthias Schober, Stefan Saager, Christoph Metzner, Uwe Vogel; Fraunhofer FEP, Germany

Acknowledgements:

The development of the new technology is the result of a project funded by the

Fraunhofer-Gesellschaft. Now the scientists are ready for specific advanced development of the technology through partnerships and joint projects with display, plant, material and system manufacturers. The results with first colored OLEDs will also be presented at the Fraunhofer FEP booth no. 50 and in poster session III during the International Meeting on Information Display - IMID 2018 in Busan, South Korea, August 29-31, 2018.

Liquid-Suspended White QD LEDs Achieve Luminous Efficacy Record

Quantum dot (QD) white LEDs that show a luminous efficacy of 105 lm/W have been developed. The QDs are liquid-based and, according to researchers, could help the LEDs achieve an efficacy double that of LEDs that incorporate quantum dots in solid films. With further development, researchers say the new LEDs could reach an efficacy over 200 lm/W.

ELECTROLUBE

THE SOLUTIONS PEOPLE

A leading light in engineering improved LED performance

We don't just strive to exceed expectations, we innovate to make the best of industry, perform better.

The LED market is the perfect example of our capabilities in action. LEDs are considerably more efficient than traditional lighting forms, but they do still produce some heat, which without thermal management will have an adverse effect on both the efficiency and operational lifetime of the LED.

From bonding and non-bonding thermal interface materials, to thermally conductive resins and protective conformal coatings, our solutions offer the ultimate level of protection and heat dissipation for your LED application.

With an expansive product range and a strong emphasis on research and collaboration, we provide a complete electro-chemical solution to the world's leading LED manufacturers.

Isn't it time you discovered how Electrolube can serve you?

+44 (0)1530 419600

www.electrolube.com



Electronic & General
Purpose Cleaning

Conformal
Coatings

Encapsulation
Resins

Thermal Management
Solutions

Contact
Lubricants

Maintenance
& Service Aids

GL OPTIC

Spectral light measurement for lab and production

Precise light measuring of LED lamps and lighting to international standards.

www.gloptic.com

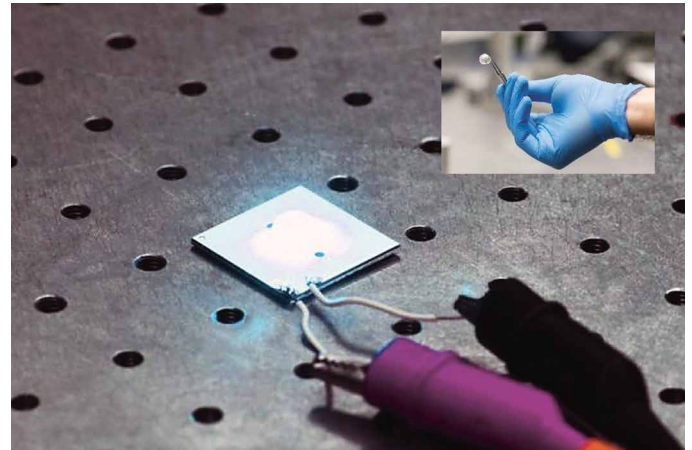

Researchers created QD-based white LEDs with a record efficacy applying QDs in a suspension rather than embedded in a solid. Inset: These LEDs use flexible lenses filled with a QD solution (Courtesy of Sedat Nizamoglu, Koç University)

The new LEDs use commercially available blue LEDs combined with flexible lenses filled with QDs. Light from the blue LED causes the QDs to emit green and red, which combine with the blue emission to create white light.

To make the white LEDs, researchers from Koç University filled the space between a polymer lens and LED chip with a solution of QDs that were synthesized by mixing cadmium, selenium, zinc, and sulfur at high temperatures. The researchers used silicone to make the lens because its elasticity would allow them to inject the solution into the lens without any solution leaking out, and because silicone's transparency would enable light transmission.

The team carried out more than 300 synthesis reactions to identify the best conditions, such as temperature and time of the reaction, for making QDs that would emit at different colors while exhibiting optimal efficacy.

"Creating white light requires integrating the appropriate amount of quantum dots, and even if that is accomplished, there are an infinite number of blue, green, and red combinations that can lead to white," said researcher Sedat Nizamoglu. "We developed a simulation based on a theoretical approach we recently reported and used it to determine the appropriate amounts and best combinations of quantum dot colors for efficient white light generation."

The researchers demonstrated their white LEDs by using them to illuminate a 7-inch display. They showed that their liquid-based white LEDs could achieve an efficacy double that of LEDs that incorporate QDs in solid films.

Although QDs embedded in a film are currently used in LED televisions, this lighting approach is not suitable for widespread use in general lighting applications, said the researchers. Transferring the QDs in a liquid allowed the team to overcome the drop in efficacy that can occur when nanomaterials are embedded into solid polymers.

The team said that the synthesis and fabrication methods it used for making the QDs and the new LEDs were inexpensive and applicable for mass production.

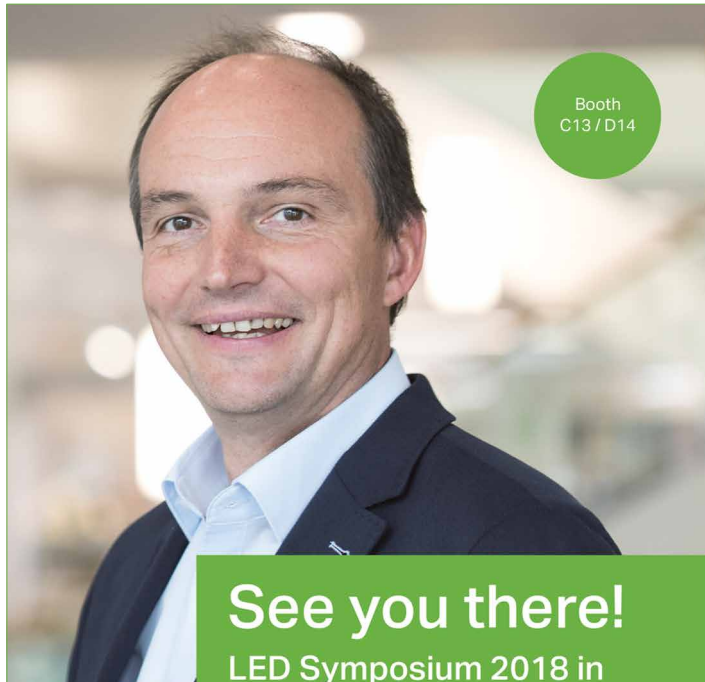

See you there!

LED Symposium 2018 in Bregenz, September 25 - 27

Discover the perfect connection technology for your LED applications. Talk to us!

www.wago.com/global/lighting-technology

As a next step, the researchers are working to increase the efficacy of the LEDs and want to reach high efficacy levels using environmentally friendly materials that are cadmium and lead-free. They also plan to study the liquid LEDs under different conditions to ensure they are stable for long-term application.

"Efficient LEDs have a strong potential for saving energy and protecting the environment. Replacing conventional lighting sources with LEDs with an efficacy of 200 lumens per watt would decrease the global electricity consumed for lighting by more than half," said Nizamoglu. "That reduction is equal to the electricity created by 230 typical 500-megawatt coal plants and would reduce greenhouse gas emissions by 200 million tons."

Unlike the phosphors that are used to create white light with today's LEDs, QDs generate pure colors because they emit only in a narrow portion of the spectrum. This narrow emission makes it possible to create high-quality white light with precise color temperatures and optical properties by combining QDs that generate different colors with a blue LED. Quantum dots are also easy to make, and the color of their emission can be easily changed by increasing the size of the semiconductor particle. By changing their concentration, QDs can be used to generate warm white light sources (e.g., incandescent light bulbs) or cool white sources (e.g., typical fluorescent lamps). ■

ELPECAST®
peters



Crystal-clear casting compounds for lighting technologies

Casting compounds of the series ELPECAST® Wepuran VT 3402 KK

- protection against environmental influences
- suitable for outdoor use under weathering and sunlight exposure, or in underwater applications
- flame-retardant / hardly flammable (UL-approved) for safety-relevant applications
- encapsulation of flexible LED strips or LED bars in aluminium profiles
- base: polyurethane resin (UR)
- highly transparent, yellowing-resistant and temperature-stable
- free from mercury

For additional high tech coatings for LED applications such as silicone resin-based casting compounds, conformal coatings, black and white solder resists or thermal transfer pastes for an efficient thermal management visit

peters
Coating Innovations
for Electronics

Lactwerke Peters GmbH & Co. KG
Hooghe Weg 13, 47906 Kempen, Germany

E-Mail: peters@peters.de
Phone: +49 2152 2009-0

www.peters.de

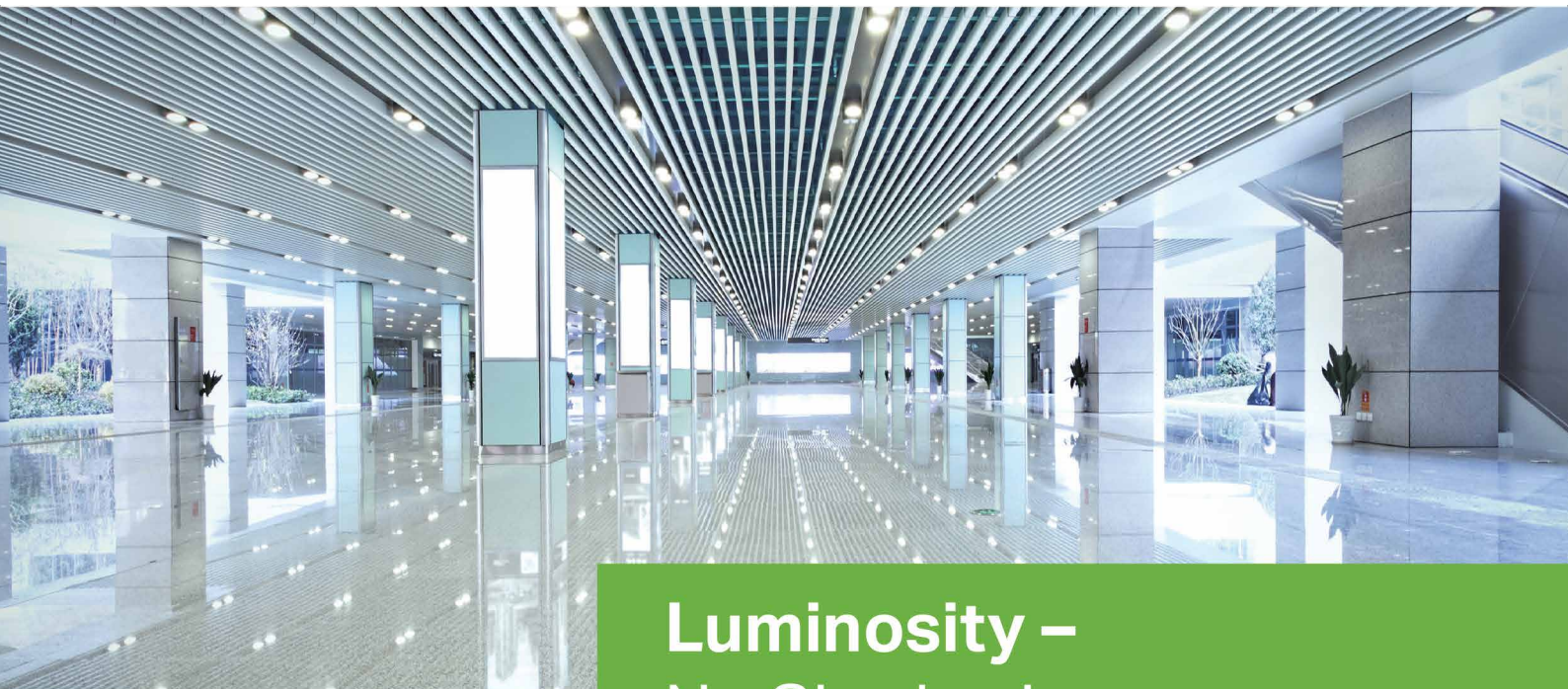

Luminosity – No Shadowing

Maximum light distribution, minimum shadowing: WAGO offers a wide product range for all LED applications. International approvals, WAGO's universal spring pressure connection technology and an ultra-compact footprint open your applications up to worldwide use. Benefit from the new 2065 Series SMD Terminal Blocks' low profile of just 2.7 mm. Furthermore, WAGO's all-new 2070 Series Through-Board SMD Terminal Blocks provide back-side wiring of LED modules, minimizing undesired shadowing and simplifying wiring. **We Connect Your Light.**



www.wago.com/lighting

WAGO

Acknowledgements:

The research was originally published on July 3rd, 2018 in *Optica* Vol. 5, Issue 7, pp. 793-802 (2018), a publication of OSA; The Optical Society (doi:10.1364/OPTICA.5.000793). The original paper can be downloaded at www.osapublishing.org/optica/viewmedia.cfm?uri=optica-5-7-793&seq=0

Cooling for Computer Chips - Maybe Also Useful for LEDs

The inner workings of high-power electronic devices must remain cool to operate reliably. High internal temperatures can make programs run slower, freeze or shut down. Researchers at the University of Illinois at Urbana-Champaign and The University of Texas, Dallas have collaborated to optimize the crystal-growing process of boron arsenide – a material that has excellent thermal properties and can effectively dissipate the heat generated in electronic devices.

The results of the study, published in the journal *Science*, mark the first realization of previously predicted class of ultrahigh thermal conductivity materials. Boron arsenide is not a naturally occurring material, so scientists must synthesize it in the lab, the researchers said. It also needs to have a very specific structure and low defect density for it to have peak thermal conductivity, so that its growth happens in a very controlled way.

“We studied the structural defects and measured the thermal conductivity of the boron arsenide crystals produced at UT Dallas,” said co-author David Cahill, a professor and head of the department of materials science and engineering at Illinois. “Our experiments also show that the original theory is incomplete and will need to be refined to fully understand the high thermal conductivity.”

Most of today’s high-performance computer chips and high-power electronic devices are made of silicon, a crystalline semiconducting material that does an adequate job of dissipating heat. But in combination with other cooling technology incorporated into devices, silicon can handle only so much, the team said.

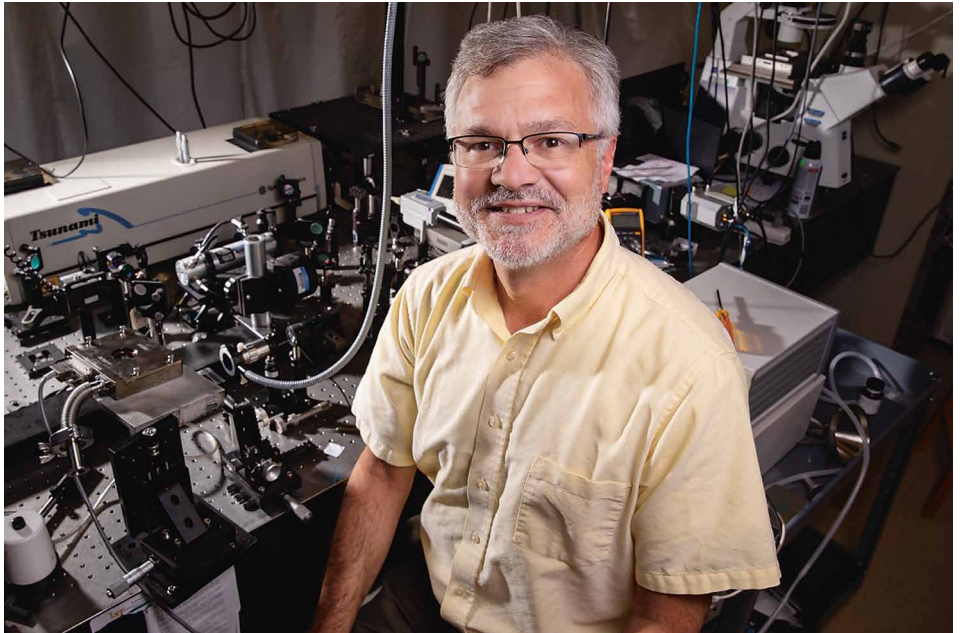

Materials science and eng. prof. and dept. head David Cahill co-led research to optimize the synthesis of boron arsenide – a highly thermally conductive material – to dissipate heat inside high-powered electronics (Credits: L. Brian Stauffer)

Diamond has the highest known thermal conductivity – about 15 times that of silicon – but there are problems when it comes to using it for thermal management of electronics.

“Although diamond has been incorporated occasionally in demanding heat-dissipation applications, the cost of natural diamonds and structural defects in manmade diamond films make the material impractical for widespread use in electronics,” said co-author Bing Lv, a physics professor at UT Dallas.

“The boron arsenide crystals were synthesized using a technique called chemical vapor transport,” said Illinois postdoctoral researcher Qiye Zheng. “Elemental boron and arsenic are combined while in the vapor phase and then cool and condense into small crystals. We combined extensive materials characterization and trial-and-error synthesis to find the conditions that produce crystals of high enough quality.”

The Illinois team used electron microscopy and a technique called time-domain thermo reflectance to determine if the lab-grown crystals were free of the types of defects that cause a reduction in thermal conductivity.

“We measured dozens of the boron arsenide crystals produced in this study and found that the thermal conductivity of the material can be three times higher than that of best materials being used as heat spreaders today,” Zheng said.

The next step in the work will be to try other processes to improve the growth and properties of this material for large-scale applications, the researchers said. ■

Acknowledgements and References:

The Office of Naval Research and the Air Force Office of Scientific Research supported this study.

The paper “High thermal conductivity in cubic boron arsenide crystals” is available online and from the U. of I. News Bureau. DOI: 10.1126/science.aat8982

InteGreat Project - New Approaches to LED Production

In the InteGreat research project, Osram Opto Semiconductors coordinated a consortium comprising seven partners from science and industry. Between December 2014 and February 2018 the project partners investigated time-honored manufacturing approaches and know-how along the entire LED production process with the aim of identifying potential areas for optimization. The new insights allow for LED products to be given additional superior properties that would have been difficult or even impossible to achieve with the technologies previously used to produce LEDs.

Osram Opto Semiconductors, Osram, the Fraunhofer Institute for Integrated Systems and Device Technology (IISB), the Fraunhofer Institute for Reliability and Microintegration (IZM), Würth Elektronik, LayTec AG and Mühlbauer GmbH & Co KG investigated new approaches for manufacturing very small surface emitting LED chips and packaging technologies, among other things, as part of the "Photonic Process Chains" initiative.

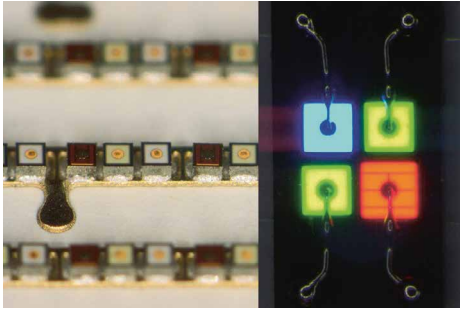

As part of the "Photonic Process Chains" initiative, new connection technologies (right) as well as approaches for manufacturing very small surface-emitting LED chips and packaging technologies (left) were investigated

At the heart of the project was wafer level packaging as well as investigations into planar contacts. One of the pioneering approaches to emerge from the project is planar interconnect technology in which the bond wire is replaced by a thin flat metal connection. This moves the surface emitter to the surface of the package. The light can therefore be used more directly, unlike with conventional components. This leads to smaller losses in efficiency and luminance and consequently to greater brilliance and cost savings in operation. Other new technologies along the entire value-added chain for functional full-color video wall modules with a pixel pitch of 1 mm were successfully demonstrated.

The results of the project can be applied not only to large-format video walls but also to new applications such as in ambient lighting and sensor systems. Thanks to the modular structure of the project comprising four work packages, many results can now be quickly transferred to product development and production. The integration of LEDs in

industrial applications and also in areas such as the mobility of the future can therefore be accelerated. The results also open up huge potential in infotainment.

"The results of the InteGreat research project represent a major advance for the future of LEDs. Our powerful consortium of partners from science and industry has delivered extraordinary achievements in three years. Once again we have been able to demonstrate the powers of innovation in Germany as a center of scientific know-how", said Frank Singer, Predevelopment Group Leader at Osram Opto Semiconductors. ■

Acknowledgements:

Innovative technologies and pioneering findings for LED manufacturing as a result of the project funded by the German Federal Ministry of Education and Research (BMBF).



EASY INSTALL

100W/150W Constant Voltage LED Driver



- With 12V 300mA Auxiliary Output option available.
- UL LED Driver, enabling drastically reduced approval times and agency approval costs.
- Plug-and-Play Conduit Entry and Wiring Compartments. Eliminates need for external Junction boxes.
- Wide Input Voltage: 90-305 VAC
- Extremely Low operating temperature -40°C to 60°C
- SCP, OCP, OTP, OVP

Visit us at booth **1-CON-003**
Hong Kong International Lighting Fair (Autumn Edition)
Learn more at www.grealpha.com



Contact us at sales@grealpha.com
US Enquiries: (770) 538-0630
Japan Enquiries: (81) 03-5403-6364
Rest of the World: (852) 2423 3332

TECHNICAL REGULATORY COMPLIANCE UPDATE



Segment	Product	Standard (Certification)	Region	Technical Regulatory Compliance Information
Regulations	LED-Modules	IEC 62031:2018	Int.	<p>IEC 62031:2018 specifies general and safety requirements for light-emitting diode (LED) modules. This second edition cancels and replaces the first edition and its amendments. This edition constitutes a technical revision.</p> <p>Few significant technical changes are:</p> <ul style="list-style-type: none"> • The scope and wording in several clauses were clarified • The marking of working voltage was modified • Requirements for other than integral terminals added • Annex B was deleted • Information for luminaire design was detailed especially for water contact & working voltage • An Abnormal temperature test was introduced - cl. 20.3, Annex D
Regulations	Luminaires, LED Luminaires, LED lamps, LED modules	ENEC + publication	Europe	<p>ENEC + is the European quality mark that ensures the performance of LEDs and Luminaires. To be eligible for ENEC+ certification, a product MUST carry the ENEC safety mark. The most advantageous part of having this single-certification mark is that it is accepted throughout Europe and beyond.</p> <p>ETICS published in May 2018 the following new documents for the ENEC+ scheme:</p> <ul style="list-style-type: none"> • ENEC 301 Annex F: ENEC+ standards covered • ENEC 324 Annex B: ENEC+ product surveillance testing program • EPRS 001 : LED module with use of EN 62717:2017 • EPRS 002 : Luminaire with use of EN 62722-1:2016 • EPRS 003 : LED Luminaires with use of EN 62722-2-1:2016 • EPRS 004 : Self ballasted LED lamps with use of EN 62612:2013 <p>The EPRS documents describe how to use the referenced standards and provide some variations to apply the standards and the number of samples. Further it also describes what will be listed in the ENEC+ certificate.</p> <p>With the new reference to EN 60969 (latest version) also CFL go under the ENEC+ scheme.</p>
Regulations	Lamps	IEC 60061-1:1969/AMD56:201	Int.	<p>The issue of the third edition splits EN/IEC 60061 - the single publication into three parts, numbered IEC 60061-1, IEC 60061-2, IEC 60061-3, covering lamp caps, lamp holders and gauges respectively. There are many models of lamps for countless applications therefore, lamp caps and holders must be standardized to ensure lamps designed for the same purpose are interchangeable. The amendment 56 to the EN/IEC 60061-1 brings in additional requirements for the max. values for the lamp caps E14 and E40.</p> <p>Lamp cap E14 sheet 7004-23 changed to version 7 with:</p> <ul style="list-style-type: none"> • Max. lamp mass/weight: not exceed 0,5kg • Bending moment: not exceed 1.0 Nm <p>Lamp cap E40 sheet 7004-24 changed to version 7 with:</p> <ul style="list-style-type: none"> • Max. lamp mass/weight: not exceed 1,5kg • Bending moment: not exceed 3.0 Nm <p>The above values should be applied when designing lamps of all kind of technologies - LED, CFL etc.</p>
Regulations	LED-Modules	IEC PAS 63166:2018(E)	Int.	<p>The Zhaga Consortium is a global lighting-industry organization that aims to standardize LED light engines and associated components such as LED modules, holders and electronic control gear (LED drivers). The Zhaga specifications, known as Books, describe the interfaces between LED luminaires and LED light engines.</p> <p>The IEC PAS 63166:2018(E) contains Zhaga Book 1 which defines the common concepts that underlie the Zhaga interface specifications and Book 7 which defines several specific LED modules with rectangular shape. With this ZHAGA transfers the first books into IEC standards.</p>
Lighting	LED products	IEC 62504:2014+A1:2018	Int.	<p>The IEC 62504:2014+A1:2018 provides terms and definitions used for LED product in other related standards like IEC 62031. The Amendment 1 of 2018 provides several adjustments for the definitions.</p> <p>The changed/additions are as follows: LED lamp, LED module, LED package, Printed circuit board cap</p>
Regulations	Luminaires, Lamps, LED modules	IEC/TR 63158	Int.	<p>The objective of IEC/TR 63158 is to establish a common and objective reference for evaluating the performance of lighting equipment in terms of stroboscopic effect. This describes the methodology for stroboscopic effect visibility (SVM) meter under different operational conditions. The stroboscopic effects considered are limited to the objective assessment by a human observer of visible stroboscopic effects of temporal light modulation of lighting equipment in general indoor applications, with typical indoor light levels (> 100 lx) and with moderate movements of an observer or nearby handled object (< 4 m/s). Details on restriction of the applicability of the stroboscopic effect visibility measure is given in Clause A.1.</p>

Disclaimer: This information is research work of TÜV SÜD Product Service and is intended for general information purposes only.

The content is publishable only after having the consent of TÜV SÜD Product Service. If it is published with any changes, the company is not liable for it. The information is subject to change and all rights for it are reserved by TÜV SÜD Product Service GmbH.

A free training can be arranged for a clear understanding of the upper stated standards.

For further information on the latest upgrades and testing standards and training, please contact cps@tuv-sud.com



CREE® XLAMP® LEDs



CREE® HIGH-BRIGHTNESS LEDs

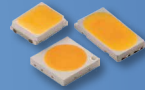

CREE® J SERIES™ LEDs

BARRIER-BREAKING, GAME-CHANGING, INDUSTRY-LEADING—WE MAY RUN OUT OF ADJECTIVES, BUT

WE'LL NEVER RUN OUT OF INNOVATION

SEE THE COMPLETE PORTFOLIO AT: CREE.COM/LED-COMPONENTS

CREE 

Planning Your LpS 2018 Is Easy with Our Simple Program Chart and Event App

SEPT 25-27, BREGENZ

LpS 2018
LED SYMPOSIUM
professional +EXPO



LpS returns this year and continues to be aimed at technology experts from industry and research, as well as those who are curious about the latest developments in lighting technology. The carefully curated program for LpS2018, together with the co-hosted TiL2018, now forms a comprehensive overview of the current developments, hurdles and solutions for the disrupted and ever changing world of lighting.

Program

LpS will bring together the greatest minds in lighting to tackle this year's key 5 topics of Strategies & Technologies, Digitization, Human Centric Lighting, Quality Engineering and Technologies in Applications.

Highlights this year include cross-sector workshops like "Wellness Real Estate, New Challenges In Health Lighting Requirements In The Built Environment" where experts from Mount Sinai Hospital NYC, Arup, Bartenbach and Broadway Malyan discuss and animate this vital issue with an emphasis on the circadian

feature of the WELL Building Standard. There are multiple sessions on our collective connected future; companies sharing their ambitions in the field include Signify, Fulham and Silvair. This year LpS opens with the keynote from Dr Guido van Tartwijk, CEO of Tridonic. He delivers his address on "The Transformation of the Lighting Industry", how different solutions can be utilized to bring about a successful transformation of the existing lighting system into a future-proof one.

www.led-professional-symposium.com/event-program-sessions

The extensive conference program encompasses strategies and markets, engineering and design, testing and applications, and covers the central building blocks of lighting systems from the component or materials right the way through to the application. In total there will be over 100 specialist lectures, workshops, and panel debates that will be enjoyed by more than 1,600 visitors, who will come together to discuss, debate, design and develop the "Lighting Technologies of Tomorrow".



Proceedings

Like every year, LpS delegates will receive the full event proceedings. An incredible resource, the proceedings booklet allows you full access to the detailed, ground breaking work from our speaker community.

Exhibition

Over 100 companies from around the world will form the go-to showcase for all things new and exciting in lighting technologies. The exhibition hall is your chance to see the latest product launches, discuss your needs with manufacturers and get hands-on experience with the latest technologies for yourself.

Event App

New to the LpS2018 and TiL2018 is a helpful information Event App. This purposely designed tool allows you to navigate the conference, tailoring the experience to your personal agenda. It is also the perfect networking companion, enabling registered users to connect and build strong

relationships. It can be downloaded from your regular app store. Search for LpS2018 and TiL2018.

Get Together & Awards Ceremony

The Get Together event and the Awards ceremony have been combined this year, and will be held on the evening of day 2. There has been an increase in the number of awards to three categories per event as well as the coveted Scientific Award for the best research paper of the year. Echoing the prestigious nature of the awards, we will be ferried across the lake on the MS Vorarlberg to the magnificent Eilguthalle in Lindau, where the ceremony will take place. Tickets are available now and can be ordered when registering for your event pass.

www.led-professional-symposium.com/registration

Co-Hosted Trends in Lighting

The co-hosted TiL event returns for its 2nd year, this year. It has evolved into an even more inspiring and vital element of the lighting industry. TiL2018 demonstrates

that lighting knows no boundaries. There are new and unexpected applications in areas like healthcare, entertainment, mobility, and agriculture, to name just a few.

Trends in Lighting is mission critical for the lighting industry in its quest to find new meanings and new relevance of light in the digital age. We have begun to explore new purposes of light and new applications that bring true value to people all over the world.

TiL2018 will bring together the greatest minds in lighting to tackle this year's key 5 topics of Lighting Heart & Soul, The Right to Create, Humanized Technology and Beyond Illumination. This year's incredible speaker, experience and workshop line-up includes LG, Boeing, Arup, LichtVision Design, Volpi, OSRAM, Zumtobel, Signify, Bluetooth, DIAL and many more.

www.trends.lighting/program-2



LPS & TIL PROGRAM

Lps 2018
LED SYMPOSIUM
PROFESSIONAL
+ EXPO



Sept. 25th, 2018

Strategies & Trends

Sept. 25th, 2018

Be Inspired

Time	Lighting Business Trends	Lighting Technology Trends	Human Centric Lighting	Debate
Time	Seestudio	Seefoyer	Propter Homines	Showfloor
Time	Interactive Sessions	Creative Talks	Debate	Showfloor
Time	Parkstudio	Seegalerie	Debate	Showfloor
09.30	Event Opening (Grosser Saal)			
10.00	KEYNOTE: The Transformation of Lighting Guido VAN TARTWIJK, Tridonic			
10.30	KEYNOTE: The Lighting Industry's Journey Towards New Growth Rogier VAN DER HEIDE			
11.30	The Roadmap of the Global Lighting Association Jan DENNEMAN Global Lighting Association	Repro-light: Modularity, Sustainability & Personalization for Lighting Industry Katrin TANZER, PhD Bartenbach	Human-Centric Lighting - Quo Vadis? Johannes WENINGER, Dr Bartenbach	Smart Building Design - Launch & Introduction of the New DIAL Design Book Michael J. IMMECKE DIAL
12.00	EU Circular Economy Policies are Impacting Lighting Product Design and Business Models Ourania GEORGIOU-SAKOU LightingEurope	Zhaga Connectivity Interfaces for Smart Cities and Smart Buildings Dee DENTENEER, PhD The Zhaga Consortium	Lighting and Ed Clinician Wellness and Performance Improvement Octavio PEREZ, PhD Mount Sinai Hospital NYC	How Automotive Designs & Approaches Can Inspire US Thomas HEBALIM, Dr Hiebaum Consulting
12.30	Ecodesign Directive and Energy Labelling Regulation - Short Term Consequences for Lighting Products Heiko BECKER Erco & LightingEurope	Lighting Goes Smart - Should We Care About Cybersecurity? Alexander W. KOEHLER, Dipl. Math. UL International	The Therapeutic Role of Process-Controlled LED Lighting to Combat the Global Epidemic of Myopia Stephen Archer MASON, Dr Sustainable Eye Health Pty	Why Is There A Light Switch on My Phone? The Importance of Interaction Design for Office Lighting Harm VAN ESSEN, Prof. Thomas VAN DE WERFF, PhD cand. Eindhoven University of Technology
13.30	EXPO WELCOME PANEL DISCUSSION: Smart Luminaries for IoT Connectivity			
14.30	The Role of Governments in the Transformation of the SSL Industry James Norman BARDSLEY, PhD International Solid State Lighting Alliance	Metameric Circadian Lighting: A Technology Analysis Tamara ABERNEUER, MSc CSEM Center Murttenz	Implications for Human-Centric Lighting Design in Tropical Nursing Homes: A Pilot Study Szu-Cheng CHIEN, Dr. Singapore Institute of Technology	Interact Indoor Navigation Applied to the Benefit of People in Shops and Offices Stefan VERBRUGH, Dr. Signify
15.00	Future-Proofing Lighting Control Systems Patrick DURAND Future Lighting Solutions	How Digital Lighting Will Further Revolutionize Automotive Lighting Pierick BOULAY YOLE Développement	Full Spectrum LEDs and Indoor Daylight Support for Health and Wellbeing Octavio PEREZ, Dr. Mount Sinai Hospital NYC	Internet of Things (IoT) 101 Emre GÜNES PLD Turkey
15.30	Managing Connected Lighting Solutions in Real Life Giovanni FREZZA, Dr. Molex	How to Solve Increasing Challenges in LED Luminaire Production Markus SPIEKERMANN, BA Eng. BUB	Putting the Smart in Smart Buildings with Bluetooth Mesh Jim KATSANDRES Bluetooth SIG	
16.30	PANEL DISCUSSION Lighting Design Debate			
17.00	The Business Case for Sensing - How to be Ready Tom GRIFFITHS, MA Eco. ams	Can the Success of OLED Displays be Transferred to Lighting? James Norman BARDSLEY, PhD Bardsley Consulting	PANEL: Human Centric Lighting Moderator: Jan DENNEMAN Global Lighting Association	Human Centric Lighting Review and Outlook Carla WILKINS Lightvision Design
17.30	Professional Lighting between Vision and Reality Christian LADE, Dr Yosloh-Schwabe	Total Lighting Efficiency: Think Outside of the Chip Tom VEENSTRA Innotec	Quality of Light: Is It All About Flickering? SIGNIFY	Sun - Culture - Perception - An Interactive Experience Gabi STERN
18.00	Horticultural LED Lighting, Market, Industry and Technology Trends Pars MUKISH, MSc Yole Développement	The Technology and Implementation of Dynamic Beam Shaping David KRIEBEL LensVector	WORKSHOP: SIGNIFY	

Sept. 26th, 2018

LEDs, OLEDs and Laser Light Sources

Sept. 26th, 2018

Materials & Engineering in Lighting

Sept. 26th, 2018

Interactive Sessions

Be Creative

Creative Talks

Debates

Time	Seestudio	Seefoyer	Propter Homines	Saal Bodensee	Parkstudio	Seegalerie	Showfloor
08.30	LEDing and Quantifying Model Variability Thomas WERELLE, Dr. PI Lighting	The Business Case for Connected Lighting and IoT Services Built on Top Thomas MODER TRIDONIC	How Next Generation Design Tools Accelerate Time to Market and Secure Design Decisions Francois MIFRAND Future Lighting Solutions	WORKSHOP: PMMA - SEE - FEEL. EXPERIENCE Hené KOGLER, Dr. Evonik Performance Materials	WORKSHOP: Quality of Light, Rethinking Lighting Specifications SIGNIFY	From Architectural Lighting to Architectural Media Brad KOERNER	
09.00	Hermetic Polymer-free White LEDs for Harsh Environments Michael KUNZER, Dr. Fraunhofer Institut Applied Solid State Physics	Benefits of an Information Centric Lighting Network Szymon SŁUPIK, MSc Eng. Silvair	Reinventing Office Lighting - The Making of an Innovative Office Task Light Till FARMERDUSTER, Dipl. Designer Licht Kunst Licht	<i>Also accessible with TIL pass.</i>		Smart Lighting Owns the Ceiling - But What About the Walls? Matthias KASSNER, DI EnOcean	
09.30	Heat Fluxes and Temperatures in Chip-on-Board LEDs for Different Package Structures and Phosphor Technologies Max WAGNER, Dr. TU Darmstadt, Laboratory of Lighting Technology	OpenAIS: Advantages of IoT Connected Lighting in Reality Stefan VERBRUGH, Dr. Signify	Injection Moulded Diffraction Gratings on Curved Surfaces. A Breakthrough for a Cost-Effective Industrial Mass-Production Manuel WALCH, Dr. kdg optocomp				
10.00							
11.00	Advancements in LED Technology Enabling High Luminance LEDs Werner GOETZ, Dr. LUMILEDS	Simulation Techniques During the Process of LED Driver Development Antonio Cuadra GIMENEZ, Beng. ELT	A New Approach to Optical Beam Shaping for Lighting Applications Based on Nano-Optics Marek SKEREN, PhD IQ Structures	WORKSHOP: Commissioning an IoT Lighting Infrastructure. What Makes it so Difficult? How the Process can be Improved? SILVAIR		LEDs in Medical Point-of-Care Testing Diagnostics - Commodity or Still Driving Technology Demand? Ulrich STARKER, MSc Volpi	
11.30	Rapid Evolution of High-Power LEDs Package from SMD to CSP to Direct Mountable Chip Xavier DENIS Nichia	Latest Development on Drivers - Control and Dimming Tobias MEYER-ANDERSEN, PhD Nordic Power Converters	Rapid Prototyping of Complex 3D Optical Components Markus POSTL, DI Joanneum Research, Institute for Surface Technologies and Photonics	WORKSHOP: What is Li-Fi? Everything You Need to Know: Opportunities & Challenges Suat TOPSU, Prof. University of Paris Saclay		What is Li-Fi? Everything You Need to Know: Opportunities & Challenges Suat TOPSU, Prof. University of Paris Saclay	
12.00	TRI-R Technology - The Light Closest to the Sun for Human Well-Being Kumpei KOBAYASHI Toshiba Materials Materials Co., Ltd.	Influence of Converter Topology on the System Interactions Markus HECKMANN, DI (FH) OSRAM	Semi-Empirical Characterization of Freeform Microlens Arrays Oscar FERNANDEZ, PhD CSEM	WORKSHOP: Ambient Communication SKANDAL TECHNOLOGIES		BIOWLIGHT - Brings Day-Light to Life Ramunas DANAUSKAS Selta	
14.00	LED Filaments - A New Technology Enables Classical Design in LED Retrofit Lamps Markus HOFMANN, DI OSRAM Opto Semiconductors	DALI-2: Standardized, Interoperable Components and Smart Luminaires Scott WADE, Dr. DIA	The T-Word: Tolerancing, and its Role in Illumination Optics Design Dave JACOBSEN Lambda Research	WORKSHOP: Visual Perception and Health - Demonstrations Wilfried POHL, Mag. rer. nat. Barrenbach GmbH		Technology Changes Our Business. A Consultants View on the Future Challenges of the Lighting Market Walter WERNER, Dr. Werner Mgt. Services	
14.30	An Introduction of OLED Lighting Technology Claudia KEIBLER-WILLNER, DI Fraunhofer	Connected Outdoor Lights and Fixture Based Sensors for Indoor Lights: Use Cases and Benefits for End User Peter DUNNE, PhD Signify	Multi-Functional Optical Silicone-to-Thermoplastic Over-Molded Component for LED Lighting Francois DE BOUYL, PhD Dow	WORKSHOP: Eye Health Stephen A. MASON, Dr. Sustainable Eye Health Pty		LED Lighting: An Active Contribution to Eye Health Stephen A. MASON, Dr. Sustainable Eye Health Pty	
15.00	The Latest Developments in Laser Light Sources For Industry-Leading Luminance Julian CAHEY, Dr. SLD Laser	Connected Emergency Lighting - Safety and Security in Controls and Emergency Lighting Jeremy LUDYJAN Fulham	Flexible Graphite for Superior Thermal Management Solutions in LED Lighting Jeff GOUGH, MBA NeoGraf Solutions			The Psychological Evolution of Urban Lighting Torsten BRAUN, Dipl. Psych. Die Lichtplaner	
16.00							PANEL DISCUSSION Innovation Debate
16.30	LED Tape for Tunable White Based on an Inductive Design Roland MICHAL, DI Dr. Bilbon	VLC Luminaire - Visible Light Communication Guido PAI, Prof. Interstate University of Applied Sciences NTB	Aluminum Oxide PCB - Technology for Developing New Generation LED Solutions Aleksy OSIN, PhD RUSALOX	WORKSHOP: Wellness Real Estate - New Challenges in Healthy Lighting Requirements in the Built Environment Octavio PEREZ, PhD Mount Sinai Hospital NYC			
17.00	Defining the Spectrum for Unique Lighting Applications, TM-30-15 and Human Centric LED Sources Tom JORY Luminus Devices	Size Matters - Small Form Factors Drivers to Support Flicker-Free Airy and Artistic Luminary Design Keith HOPWOOD, BSc Seoul Semiconductor	Cost-Effective Manufacturing of High-Quality ITO Thin Films on 300 mm CMOS for Next Generation Display Technologies Claudia Valentin FALUB, Dr. Evatec				LPS & TIL 2018 PRESS CONFERENCE
17.30		Requirements on High Performance LED Driver for Professional LED Lighting Ulrich VOM BAUER, DI Infineon Technologies					
18.30	18.30-24.00 Get Together / Award Ceremony (Boat tour to Lindau)						

LPS & TIL PROGRAM

Lps 2018
LED SYMPOSIUM
+ EXPO



Sept. 27th, 2018

Systems & Applications

Sept. 27th, 2018

Take Action

Lighting Applications

Lighting Quality & Testing

Lighting Requirements

Interactive Sessions

Creative Talks

Debate

Time	Seestudio	Seefoyer	Propter Homines	Time	Parkstudio	Seegalerie	Showfloor
08.30	The Dark Side of Light: Effects of Light Pollution on Insects and Agriculture Meja GRUBISIC, Dr. Leibniz-Institute	How to Tackle the Increasing Complexity at Legislative Compliance Jacob NUJESINK DEKRA	Spectral Innovations in Theater Lighting Markus RESINGER, DI Reisinger Studios	08.30	WORKSHOP: What OLED Holds for the Future of Lighting Luflex - LG OLED LIGHT LG DISPLAY	WORKSHOP: Human Centric Lighting - Designing and Operating Lighting with Human in the Center ZUMTOBEL	
09.00	LEDs Solutions for Sports Lighting Shih-Shun CHANG, Dr. LUMILEDS	Aging of Potted LED Modules under Realistic Conditions Thomas SCHULZ, DI (FH) LUMITRONX	Can Entertainment Lighting Requirements be Combined in a Comprehensive Lighting Solution Dipl.-Wirtsch.-Ing. (BA) Ing. OETHG				
09.30	Dynamic Light in a Static Luminaire Based on Micro-Tracking Technology Noé BORY, MSc Insolight	Reliability of New Light Quality Metrics: Challenges and Opportunities Benoit HAMON, PhD PI Lighting	Modern Lighting Audits - Technology Supporting Designers and Contractors to Verify Lighting Installation Quality Miko PRZYBYLA, MA GL Optic	09.30		The Future Everyday with Intelligent Lighting Harm VAN ESSEN, Prof. Thomas VAN DE WERFF, PhD cand. Eindhoven University of Technology	
10.30	Plant's Responds to Exposure of Different Lighting Conditions Volkmar KEUTER, DI Fraunhofer Institute	Destroy in the Lab to Last in the Field - LED Robustness, Reliability and Life Time Testing Alexander WILLM, DI OSRAM Opto Semiconductors	WORKSHOP: Lighting & Laser Projection for the Entertainment Industry Jose POZO, Dr. EPIC <i>Also accessible with TIL pass.</i>	10.30	WORKSHOP: Bended LED Lighting. Bring your Bended Design to Light OLEDWorks	Semantic Light - Where Light Meets Artificial Intelligence (AI) Zary SEGALL, Prof. The Royal Institute of Technology	
11.00	Closed Loop Control Systems for Supplementary Lighting in Smart Greenhouses Viktor Zsellers ARROW	Temperature Profiling of Secondary LED Optics by Infrared Thermography Peter W. Nolte, Dr. Fraunhofer Institute		11.00		LIGHTTELLIGENCE - IoT Business in Lighting Christoph Peitz, Dr. Osram	
11.30	Universal LED Tubes - Detailed Descriptions of Design, Technologies and Markets Marlijn Dekker, Dr. Seaborough	Light Flicker: A Reasonable Measurement Method in View Peter Erwin, DI Der Lichtpeter		11.30		Human Centric Lighting Apart from Tuneable White LEDs Stefan LORENZ, Dr. OSRAM Opto Semiconductors	
12.00				12.00			PANEL DISCUSSION CEO Debate
13.00	Water Metering Data Acquisition and Transmission Through Street Lighting Enabled Network Arturo RUBIO-DOBON, BEng. ELT	Effects of Temporally Modulated Illumination to Human Beings Markus CANAVEZI, DI MMag. Bartenbach	WORKSHOP: Solid-State Lighting Measurements Denan KONJHOZIC, Dr. Instrument Systems	13.00	WORKSHOP: LFI End-To-End OLEDCOMM	UrbanLight - Optimized LED street lighting for Vienna Wilfried POHL, Mag. rer. nat. Bartenbach	
13.30	Luminaire Efficiency - A Proposal to Think Different Andreas NIEDERSTÄTTER, MSc Swarflex	Miniaturization & its Consequences Marcel HUBELI, MSc Bartenbach, Nordic Power Converters		13.30		Light is the Source of Well-Being: HCL for Large Surfaces Michele GARDENAL, MBA OSRAM	

CLOSING

14.30

Clever solutions for a changing world

Fulham's powerful, innovative LED drivers bring tomorrow's technology to today's luminaires.



HotSpot Plus:

The All-in-One Emergency Driver

The first fully integrated programmable LED driver, emergency LED driver, and replaceable backup battery. Reduces costs, simplifies installation, and brings emergency capability to smaller luminaires.



Advanced Indoor and Outdoor Drivers

Fulham's versatile drivers are designed for exceptional performance and reliability. Featuring programming capability, compact form factors, and a range of dimming options and power levels.

FULHAM
Lighting... Global. Clever. Sustainable.

Learn more at our upcoming event

LED Professional Symposium + Expo | Stand B2
25-27 September | Bregenz, Austria

www.fulham.com

Europe | sales.eu@fulham.com +31 72 572 3000
North America | order@fulham.com +1 323 599 5000



T1A1UNV210P-60LES
60W Outdoor DALI Driver



L1V1230105S-25E
25W Universal Mains Dimmable Driver



FHSAC1-230-45CE
45W All-in-One Solution

Adaptive, Dynamic and Intelligent Lighting

Previously, most lighting applications were designed to ensure suitable visual conditions, to support the most demanding visual task anticipated, whilst also taking into account requirements to provide adequate levels of visual comfort and aesthetics. In most cases this was a static lighting solution because the options to change light levels, luminance distribution, or light source spectrum were limited. Tasks, occupants, and needs change from time to time, making control over the lighting desirable, if unattainable. Advanced LED and controls technology make the unattainable possible; now, the key questions are also for CIE how to define the user needs for various applications and how best to set up lighting systems to be adaptive and intelligent in response.

The user should be the focal point of any lighting application, regardless of whether the lighting is for a work place, for home and leisure, or artistic impression. Guidance documents provide quantitative photometric parameters for many applications. These include: horizontal and vertical illuminance and luminances, the luminance and illuminance distributions, light source chromaticity color rendering, and energy

performance. The photometric parameters today are based on visual needs for adequate light to see and sufficient control to prevent discomfort associated with glare. There is increasing interest in adding parameters to address ipRGC-influenced light responses (also known as integrative lighting or human-centric lighting), although such criteria for these parameters have not yet been established.

The Role of Adaptive Lighting

The role of adaptive lighting (sometimes called “smart lighting”) is to adapt in a holistic way the whole set of lighting parameters to the current needs of users depending on current conditions, changing in response to changing conditions that include the availability and quality of daylight, occupancy pattern of users, and user preferences. Dynamic lighting can change according to pre-set dynamic variations or in response to manual controls, but adaptive

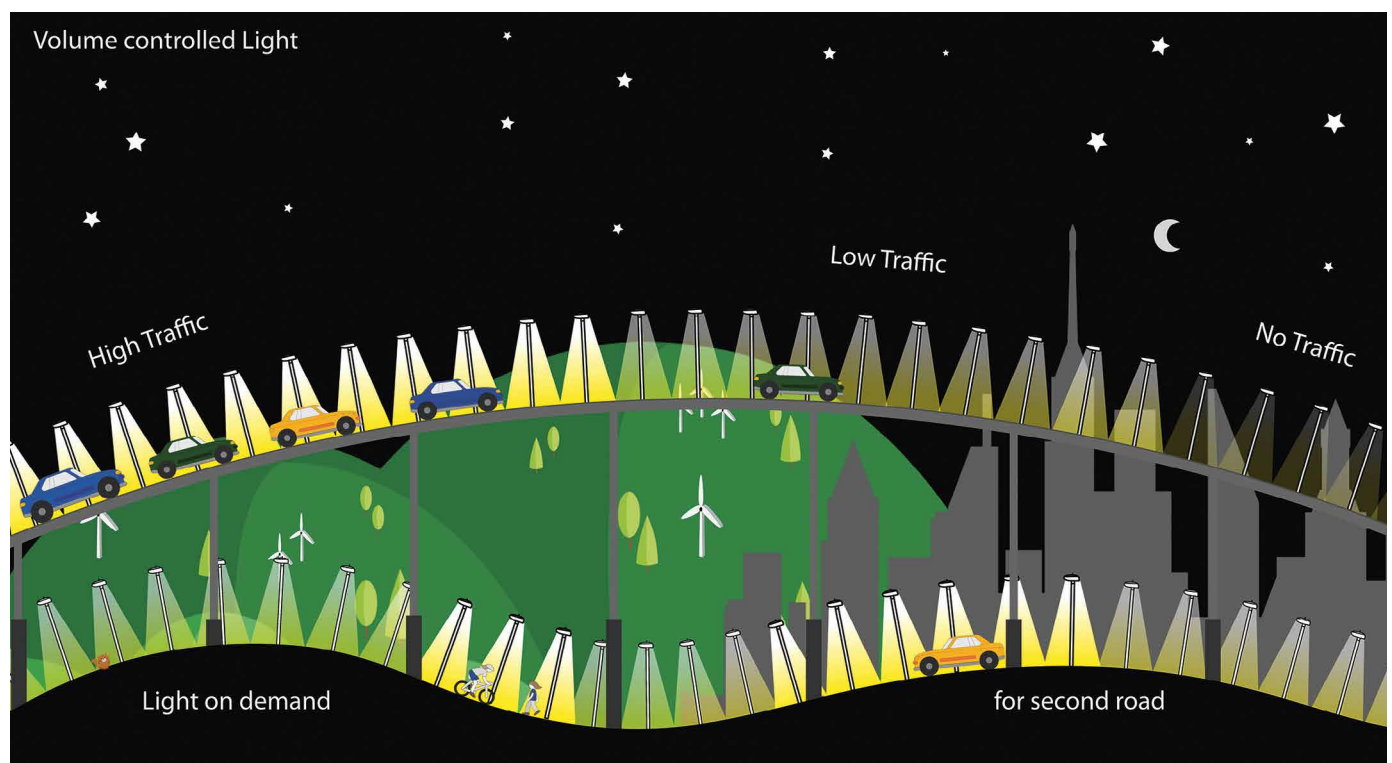

Adaptive, intelligent lighting is not just a topic for indoor lighting but at least equally relevant in outdoor lighting (Credits: ©esave ag)

lighting detects current conditions and response accordingly. If automatic functions are incorporated, and even more, if these are based on advanced technologies like fuzzy-logic, genetic algorithms or neural networks, we can call such systems “intelligent”.

The adaptability of a lighting system can be classified into four levels:

- Level 1 - adaptation using time schedules based on statistics
- Level 2 - adaptation on demand using local sensors or individual local controls
- Level 3 - adaptation with links to intelligent systems such as Building Automation Systems (BAS) for buildings and Intelligent Transport Systems (ITS) on selected roadways
- Level 4 - adaptation combining the options of Levels 2 and 3, for example:
 - scheduled changes in light source color or level to mimic daylight patterns, with or without local occupancy detection, task tuning, or daylight harvesting
 - adaptation with links to ITS systems on all roadways with electrical and lighting management systems (ELMS) control
 - luminance monitoring
 - lighting-on-demand - lights that are activated by immediate need and otherwise are dimmed or switched off, e.g. with Connected Vehicle Technology or in response to local occupancy signals
 - smart city and smart building applications

How to Use the Technologies for Adaptive Lighting

The technologies to provide adaptive lighting are already in the marketplace and are accepted by some jurisdictions. Nonetheless, we have an inadequate understanding of how best to use these technologies, meaning that installations might not serve users well, and in the worst case, might lead to harm. Lighting researchers can generate the knowledge needed to support the best application of adaptive lighting technologies.

The International Commission on Illumination (CIE) understands the importance and urgency to deal with problems of adaptive, dynamic and intelligent lighting in all application fields. Hence, this topic is a highlight of CIE's research strategy.

Key research questions are:

- What is the impact of adaptive lighting on user behavior or reactions, such as occupants' space perception or driver safety?
- How should the system adapt itself to the circumstances to provide optimal lighting? For example:
 - Could the system detect individual needs for varying visual conditions?
 - Could roadway lighting vary depending on traffic composition, traffic density, and weather conditions?
- What are the relations between lighting settings and user safety and comfort?
- Which types and levels of dynamics are acceptable in a lighting installation?
- Which types of input and feedback (e.g. road surface luminance monitoring, photocells, presence detection, algorithms for integrated multi-sensor input, automated fault detection) are necessary to ensure system usability?
- What are the energy and operational costs and benefits of adaptive lighting?
- Could adaptive exterior lighting have ecological benefits beyond energy savings?

The CIE has previously published two technical reports that fully (CIE 222:2017) or partly (CIE 205:2013) deal with problems of dynamic, adaptive and intelligent lighting in buildings.

CIE 222:2017 - Decision Scheme for Lighting Controls in Non-Residential Buildings:

This report offers guidelines in order to balance lighting quality, user comfort and energy efficiency in lighting controls solutions for lighting in non-residential buildings (i.e. for commercial, institutional and industrial buildings). It provides a decision scheme with a focus on the user requirements (visual comfort, performance, personal control) to determine the most applicable control solution, including the consequences for possible savings. In this, it assumes that there are no technological or financial hurdles. The decision scheme identifies 16 possible control strategies, for both daylight and electric lighting, and provides guidance for which strategy would be most effective in each of the 12 cases defined by space usage and occupancy.

CIE 205:2013 - Review of Lighting Quality Measures for Interior Lighting with LED Lighting Systems

This report provides information on the suitability of existing lighting quality measures when applied to (commercial) interior LED lighting systems. It identifies the gaps and weaknesses in existing quality measures, recommends new quality measures and includes suggestions for required research.

CIE Technical Committees Are Addressing Adaptive Lighting in Transport and Roadway Applications

TC 4-51 - Optimization of Road Lighting:

Objective of this TC is to develop guidance on optimization of road lighting to balance the benefits and costs where primary issues include accident risk and energy consumption.

C 4-47 - Application of LEDs in Transport Lighting and Signaling:

This TC aims to review the application and methods of measurement of LED Systems in transport lighting and signaling and to provide recommendations for the visual characteristics of LED signals and lighting as far as they affect the visual performance of the users of the transport system.

Summary & Conclusion

Current research on adaptive lighting was a focus of discussion during the CIE Topical Conference on Smart Lighting, held earlier this year in Chinese Taipei. The conference addressed key questions in this field and provided space for topical tutorials, a panel discussion on standards needed for smart lighting and a site demo presenting a practical application of smart lighting at a pier in Keelung City.

Although adaptive lighting installations are few in number today, the pace is increasing. The time for researchers to address the CIE Research Agenda questions is now, so that the future of adaptive and intelligent lighting rests on a solid foundation of research and standardization. ■

Zhaga Enables Mechanical IoT-Upgradability for Outdoor LED Lighting Fixtures

The Zhaga Consortium is a global association of lighting companies that is standardizing LED luminaire components interfaces. The latest specification from Book 18 defines a standardized interface between outdoor LED luminaires and modules for sensing and communication.

Dee Denteneer, Zhaga Secretary General, explains how the New Book 18 helps bring the Internet of Things to the outdoor lighting market via smart, upgradeable, future-proof fixtures.

Zhaga's first concrete contribution to IoT is the recently completed Book 18 Ed. 1.0 that specifies the mechanical interface between outdoor LED luminaires and extension modules (Figure 1).

This specification makes it easy to upgrade conforming outdoor LED fixtures by adding or changing 24 V modules that provide sensing and communication capabilities. This adds flexibility and value to these luminaires and gives assurance to our end-customers that the luminaires are future proof.

In this article, we first introduce connectivity interfaces, their use in smart city scenarios: stressing the value of standardization, interoperability, and certification. Next, we zoom in on the technical features of Book 18 Ed. 1.0, which defines the mechanical aspects of the interface; including topics like vendor differentiation and a benchmark against NEMA C136.10. Lastly, we sketch the path towards Book 18 Ed. 2.0, which will additionally specify the electrical and control aspects of the interface, covering our collaboration with the Digital Illumination Interface Alliance (DiiA) and how to move from a mechanical interface to a plug-and-play interoperable proposition, driving growth for the lighting industry.

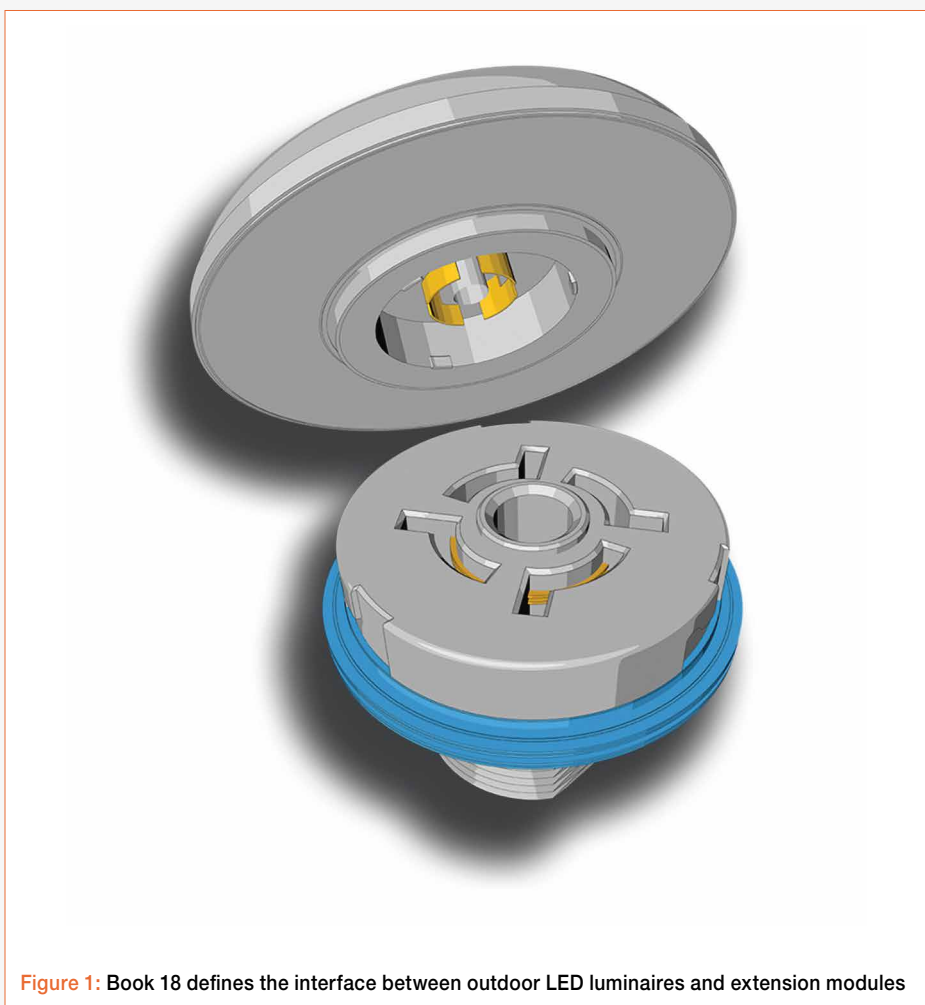

Figure 1: Book 18 defines the interface between outdoor LED luminaires and extension modules

Smart City Scenarios

The lighting industry is keen to play a central role in the business that comes along with emerging smart-city propositions,

and definitely has a right to this role because of the access to the power grid offered by outdoor luminaires and their high density in cities.

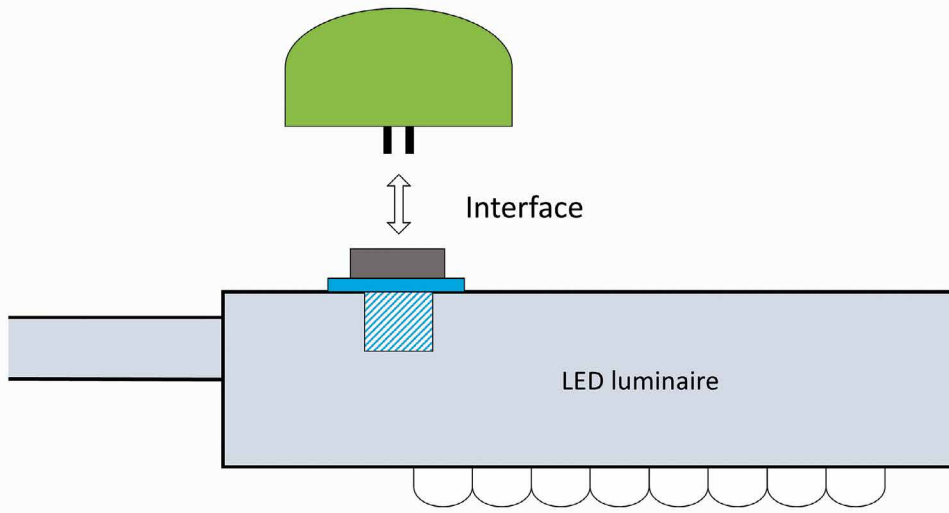

Figure 2: A well designed interface between the luminaire and an external intelligent or connected extension module makes the luminaire upgradeable

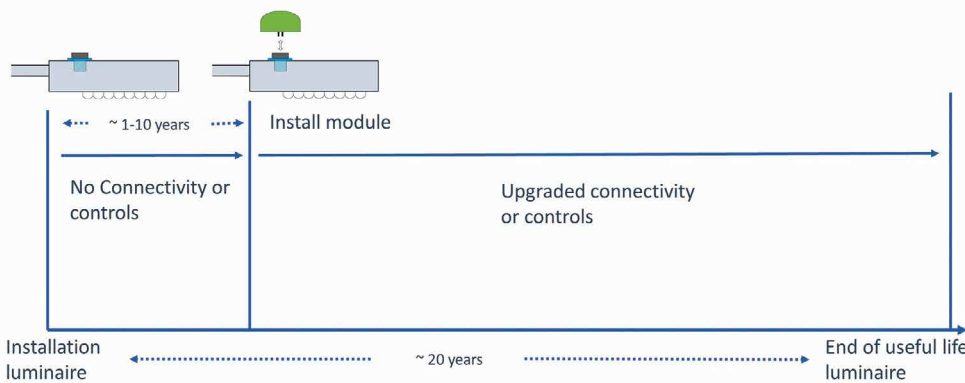

Figure 3: IoT upgradeable luminaires future proof the luminaire by enabling deployment scenarios in which the sensor or communication functions are added, or replaced, during the luminaire lifetime

Yet lighting is also confronted with a smart-city dilemma. There is still huge uncertainty concerning the preferred business propositions that will transition the smart city from promise to reality, and the connectivity and sensing technologies that are to be included in outdoor luminaires. Moreover, these propositions may very well depend on local conditions and preferences and may change over time, as may technology preferences. And yet we are installing outdoor LED luminaires right now.

Failure to resolve the dilemma hampers the installation of smart luminaires, and, consequently, prevents the lighting industry from assuming a central role in the smart city. Our right to play a role may then be superseded by faster movers in other industries.

IoT Upgradeable Fixtures

This smart-city dilemma is resolved by means of an interface that sits between the luminaire and an external “intelligent” or “connected” extension module (Figure 2).

Such an interface, if well-designed and meeting smart-city requirements, future-proofs the luminaire as it enables upgrades achieving conformity of the luminaire to new needs and insights. It thus breaks the impasse and allows for the installation of smart-ready and upgradeable luminaires right now.

Several deployments are possible with this interface. For instance, a luminaire may be installed without any sensing or communication technology present. As needs arise, new communication

or sensing functions can be added by mounting an appropriate external module onto the luminaire (Figure 3). Alternatively, the modules may be included at installation time based on a communication technology, A. As time passes by, communication technology A will be superseded by a faster revision or by a competitor technology B. The module can then be unmounted and replaced by a new module that implements this improved technology.

To enable smart city scenarios and IoT upgradeable luminaires, it is mandatory that the interface is developed as a standard that supports interoperability between luminaire and extension module.

The interface should enable interoperability to ensure that the external module will work with the luminaire, whenever it fits. This feature is essential for scenarios in which a luminaire is upgraded in the field in minimal time by a non-lighting expert. The interface should be a standard to drive the acceptance and installed base of IoT upgradeable luminaires. A large installed base of IoT upgradeable luminaires will drive the development of smart modules that match the luminaires, which will add value to the luminaires and drive the installed base. It seems impossible to get these reinforcing dynamics and scale without a standard.

Most importantly, without a standard, customers will not be convinced that the luminaire can indeed be upgraded for its lifetime at reasonable costs in a multi-vendor eco-system.

This idea is so natural that it seems hardly likely that it has not already been picked up elsewhere. In fact, it has and there is a successful predecessor in the existing ANSI/NEMA standard C136.41-2013. However, Zhaga has modernized the concept and redeveloped the concept for the LED era.

The Value of Standards, Interoperability, Certification

The value of standards for the high-volume lighting businesses has been the initial driving force behind Zhaga [1]. In its more recent evolution, the organization has widened its scope to better address interfaces for smart components, such as sensors and connectivity modules, its support of emerging business propositions from IoT and service economy, as well as its commitment to interoperability [2].

Zhaga has always promoted a restrained approach to standardization specifying only those aspects of an interface needed to support interoperability: Remove arbitrary variation in interface parameters that do not add value for the customer but leave ample room for vendor differentiation.

Furthermore, testing has also always been an integral part of the standardization. This has been included in so called “round robins” during specification development as well as in testing and product certification. The availability of testing and a logo program is a key asset to demonstrate interoperability, which is essential for specifications targeting non-lighting specialists as well as product companies from different industries.

Phase 1: The Mechanical Interface and Vendor Differentiation

Street lighting is a large part of the outdoor lighting market and a focus point for smart cities, yet has largely been ignored by standardization, with only North America having a published standard for a connection between a luminaire and a control node. The Book 18 Ed. 1.0 provides an alternative interface. While defining the mechanical fit and designation of the four electrical contacts, many of the non-critical aspects are not restricted by the specification. Design freedom is therefore still provided for a manufacturer to design for unique application complexities and thereby the specification allows for vendor differentiation.

By 2019, 91% of all newly installed streetlights will be LED. Book 18 Ed. 1.0 is an updated solution specifically for the new world of LED lighting. It defines the mechanical interface between a module (control node) or cap and receptacle.

As stated the connector is a four-pin interface. A DALI 2.0 inter luminaire communication bus has been selected as the protocol to provide 2-way control between modules and an ECG (Electronic Control Gear). Therefore, using two of four the pins. The system doesn't take advantage of DALI's ability to be polarization free, but instead sees a greater benefit to have a 24 V auxiliary power supply share its 0 V line with DALI, reducing the pin count and reducing the cost of the connector. Although the DALI bus is a powered bus, being able to power a device with a load up to 250 mA, the 24 V pin will allow devices with greater power demands to be connected. The fourth pin is a digital I/O and the detailed specification in phase 2 will define its use.

Mechanically the book has been carefully written to define only the interface features. Though the Book 18 Ed. 1.0 product does speak to the ANSI C136.10 design, having curved flag shaped contacts and a rotary locking mechanism. That is where

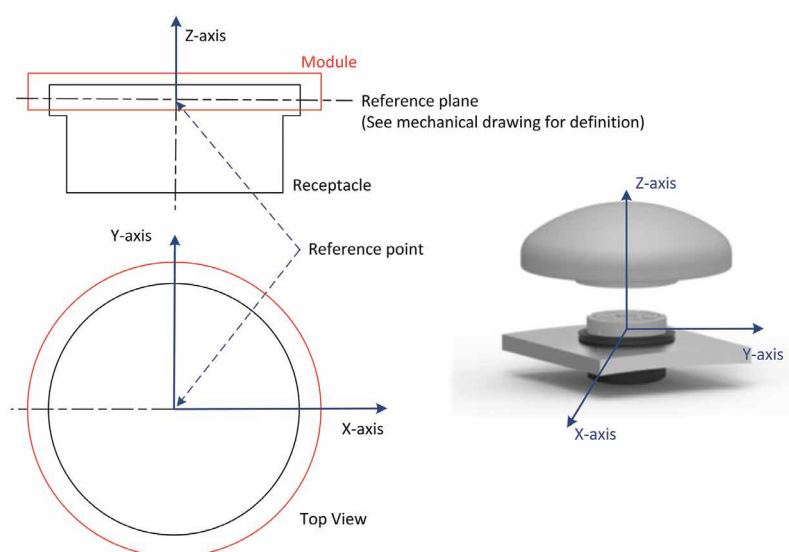

Figure 4: Positions of the reference point, the reference plane and reference axes of the Receptacle and Module

the similarity ends: It is not designed for a power switching architecture, but instead allows designers to focus on compact elegant control nodes. After all, the locking interface and also the overall diameter of the connector is approximately only 30 mm in diameter. This small diameter, just by the area it takes up, makes it much easier to seal to the luminaire. The book doesn't restrictively define the seal, instead defines it by a mating surface and a keep out zone. It does allow for designs where a single seal can provide ingress protection between the receptacle, luminaire and module. Rather than a solution that needs a seal between receptacle and luminaire and a second seal between receptacle and module. The seal is not restrictively defined, as to allow for seals that are designed to work with heavily contoured luminaires, not just flat surfaces. This does not compromise the quality of the product, which the book delivers, as the certification process tests for product compliance.

The locking features also act as a key, making sure that a module only fits to a receptacle in one orientation. Not only does this mean that contacts cannot be misaligned, but where a module needs to have a specific orientation to the streetlight and hence the roadway, this is also realized. This is a necessity for such applications like motion sensing.

Contained in Book 18 Ed. 1.0 is a detailed description of how a manufacturer must align a receptacle with respect to the luminaire. Ensuring that whatever functionality the module has, it can be realized on multiple designs and multiple manufacturer's streetlight.

The seal example is just one way that differentiation can be achieved. For the module and sealing cap, again the interface is defined, but outside a keep out zone for the diameter, there is design freedom. So, if you are adding rigidity to survive an IK09 impact test or features to blend a module into the luminaire, the Book 18 allows for it. For the receptacle the design freedom is around how it is electrically connected to the internals of a luminaire. Whether flying leads or a

"connectorized" solution is needed, again Book 18 allows for it.

Despite of the strong specification it also allows the industry to have product differentiations, which is often achieved through innovation. Book 18 Ed. 1.0 doesn't limit this innovation. Instead identifies only the aspects of the interface that guarantees the fit system, meaning that any Book 18 compliant module will fit with any luminaire that has the Book 18 receptacle. Fit systems are the corner stone of any ecosystem allowing upgradability and serviceability through interoperability.

Phase 2: The Power and Control Interface

Phase 2 of Book 18 will be Zhaga's first specification offering a fully interoperable solution. To ensure true interoperability between modules and drivers of various manufacturers, the mechanical interface and electrical pin assignment needs to be complemented with the power and control interface specification. As indicated before, the 4 pins of the connectivity interface are the 24 V DC power supply, the DALI control lines and a so-called general digital I/O pin which will be reserved for future use are not part of Book 18 Ed. 1.0.

The 24 V DC power is an auxiliary supply for demanding connectivity or sensor applications requiring average power levels up to 3 W, allowing pulsed mode operation up to 6 W. The power supply specification also describes the start-up sequence including maximum start-up time and supply current capabilities during start-up.

For the interface specification of the two DALI pins, Zhaga has set up a liaison with the Digital Illumination Interface Alliance (DiiA) to align specification in Book 18 Phase 2. From a specification organization point of view, the DiiA has split the related interface protocol into 4 different parts, describing the following aspects: integrated DALI power supply, asset management of the luminaire, energy reporting and diagnostics.

Benchmarking: NEMA ANSI C136.41-2013

Book 18 Ed. 1.0 offers a number of advantages compared with the existing ANSI/NEMA standard C136.41-2013. These advantages are directly related to the underlying system architecture, which is based on a low voltage driver - module interface. This non-mains interface enables a more compact form factor of the connector, leading to a significant size and cost reduction of the corresponding receptacle (i.e. diameter reduces from 66 to 30 mm). The receptacle also allows for more flexible mounting options such as bottom and side mounting of the modules (Figure 5). This will initiate many more new connectivity but also sensor applications, such as e.g. movement detection under the pole.

This architecture also removes redundancies at system level, removing the need for double surge protection and multiple power conversions from mains to low voltage DC in both driver and controllers. In the preferred architecture functions like energy metering (1% accuracy), asset management and diagnostics are covered by the driver. As a result, the luminaire integration is simplified as less wiring and components are required.

Next to above-mentioned benefits, guaranteed interoperability of modules and drivers is one of the most important promises. The specified DALI-based interface ensures that driver and controllers speak the same controller language. On the contrary, the C136.41 specification leaves room for different dimming standards (i.e. DALI and 0-10 V) leading to interoperability issues when exchanging or upgrading luminaires in the field.

In short, the Book 18 interface specification offers luminaire OEMs and smart cities companies a compact, cost sensitive and easy-to design in solution. In addition, the single gasket receptacle design offers a robust and waterproof solution for a wide range of outdoor luminaire applications. True interoperability is thereby the most important promise.

A Growing Eco-System

Although the Zhaga vision on IoT upgradeable outdoor luminaires is still unfolding, early signs of success are already visible. Products are available that conform to the mechanical interface, and that support the development of IoT upgradeable luminaires as well as external modules. Products in scope are receptacles along with caps to be integrated with the luminaire. A second set of products support the development of external modules and comprises base plates on which to integrate the sensing and connectivity boards, along with domes (Figure 6).

The certification program for these products is now open and first products have been certified. As another early sign, there is reference to the Zhaga interface specification in specifier documents [3], and a lot of interest has been expressed by other specifier organizations. Meanwhile, a number of luminaires are already available that support this interface. Also on the market are several external modules supporting a variety of sensing modalities, such as motion sensing and light measurement, or light management via a number of connectivity technologies, such as 3G and LORA.

Conclusion

Zhaga is in the process of implementing its vision for the outdoor connectivity interface, as described in this article. There is a strong belief that this connectivity interface will enable growth for the lighting industry, secure a central role for lighting in the smart city, and add value for all players along the lighting value chain. The early signs of adoption provide concrete proof points for the success of this vision. Following a similar vision for indoor lighting, a white paper on this topic is available [4], and a working group has recently been established. Specifications are in the making to implement the New Zhaga's vision for other components in the luminaire as well. ■



Figure 5: The Book 18 interface design well supports external modules that are mounted underneath the luminaire



Figure 6: Products are becoming available that support the development of both luminaires: receptacles and seals, as well as the development of external modules: base plates and domes functions are added, or replaced, during the luminaire lifetime (Credits: TE Connectivity)

References:

- [1] Dee Denteneer; Zhaga Gets Smart: Addressing the Industry Need for Smart Lighting and Standardized LED Components; LED Professional Symposium 2016, Bregenz
- [2] Dee Denteneer: Introducing the NEW Zhaga: Smart standards. Smarter lighting, LED Professional Review, Issue 68, July/Aug 2018
- [3] IPWEA, Model Public Lighting Controls Specification: Street lighting and smart controls programme version 1.0, Institute of Public Work Engineering Australia, 2018
- [4] Jan de Graaf et al. The NEW Zhaga develops connectivity interface standards for indoor luminaires; Zhaga white paper, 2018

LpS 2019

LED SYMPOSIUM
professional +EXPO



***The lighting event
for technologies
of tomorrow***

LpS is Europe's leading international lighting technologies conference and exhibition for **DESIGN, TESTING** and **PRODUCTION** of lighting systems, controls and equipment.

9th International LpS | September 24th - 26th 2019 | Bregenz | Austria

Organized by

LUGER RESEARCH
Institute for Innovation & Technology

Co-hosted with



www.lps2019.com

Evaluating Performance of LED-Based Luminaires

The wide spread of performance data supplied by manufacturers make it difficult for the professional user to reach an “apple-to-apple” comparison, especially if the data is not based on standardized metrics. This is however critical for the preparation of lighting projects or tender specifications. Experts from LightingEurope have therefore developed a guidance document which recommends a fixed set of performance data for LED based luminaires, with particular emphasis to the useful life and the data which is necessary for lighting application design.

Today, the preparation of lighting projects or tender specifications is more difficult than ever. Manufacturers of LED based luminaires provide different performance data for their products, often not based on standardized metrics, making it impossible to allow for an “apple-to-apple” comparison.

The intention of this article is therefore to give users, like specifiers, lighting designers, technical engineers and policy makers a guideline on how to define performance requirements, in particular related to the term “useful life or lifetime”. This article recommends a fixed set of performance data for LED based luminaires. This data set is focused on the information which is necessary for lighting application design.

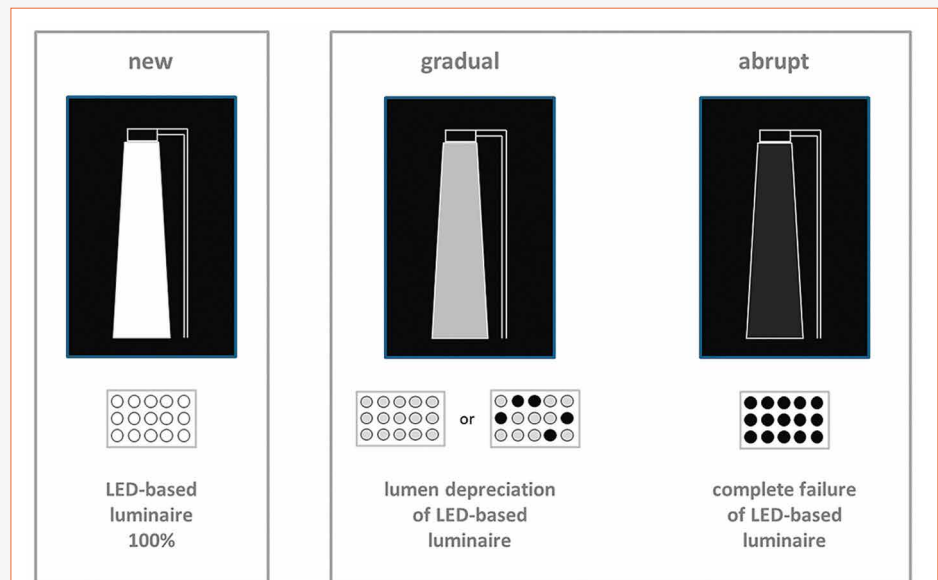

Figure 1: Evaluating “initial” and “useful lifetime” performance of LED based luminaires

Evaluating Performance of LED Based Luminaires

While the quality of LED technology has rapidly improved and the application considerations have not changed, the product data have remained unnecessarily complex. The main challenge for the professional market is to improve the way users of LED based luminaires evaluate the performance data of different manufacturers when preparing lighting projects or tender specifications.

Both “initial” and “useful lifetime” performance data should be evaluated to have confidence in how LED based luminaires will perform and how long they

will sustain their rated characteristics over their years of operation.

At present, evaluating LED based luminaires is complex because of two main reasons:

- The use of different technical definitions and related parameters to describe the performance of products, thus making them difficult to compare (for example the incorrect use of LED module or light source data instead of luminaire data)
- The technical design choices made for a product can make a tremendous difference in terms of performance over the useful lifetime

The establishment of simplified performance metrics that support the needs of good lighting design and allow easy product to product comparisons to be made can add value to the professional market.

Confusion due to the use of different sets of definitions can be eased by following the latest IEC/EN standards on performance of LED based luminaires. These standards give guidance on “what” (phenomena and metric) to publish and “how” (measurement and/or calculation method) to arrive at a set of comparable product specifications.

Lighting Requirements

Good lighting design calculations require different technical product parameters based on standardized and therefore comparable data. IEC 62722-2-1 Performance requirements for LED based luminaires, gives the following overview of the relevant “initial” and “useful lifetime” product information parameters that should be used for the planning of lighting designs.

Parameters to be considered for planning of lighting design:

- Rated input power (P in W)
- Rated luminous flux (Φ in lm)
- Rated luminous efficacy (η in lm/W)
- Rated luminous intensity distribution (in cd or cd/klm)
- Rated correlated color temperature (T_{cp} in K)
- Rated color rendering index (CRI)
- Ambient temperature related to performance of the luminaire (t_q in °C)
- Rated median useful life (L_x in hours with x for the associated rated luminous flux maintenance factor in %)
- Rated abrupt failure value (in %)

In this context “rated” means the value of the parameter for the LED based luminaire declared by the manufacturer when operated under specified conditions. It is reminded that the t_q value for which the performance data is declared shall always be reported even if this is 25°C. Where applications require t_q temperatures other than 25°C all performance data is required to reflect the actual performance for these specific t_q temperatures.

No	IEC 62722-2-1	EN 12464-1	EN 12464-2	EN 15193	EN 13201-2	EN 13201-5	EN 12193
1	Input power			x		x	
2	Luminous flux	x	x		x		x
3	Luminaire efficacy			x		x	
4	Luminous intensity distribution	x	x		x		x
5	Correlated Color Temperature	x	x		x		x
6	Color Rendering Index	x	x		x		x
7	Ambient temperature	This value is not directly required by the standards but the value is fundamentally necessary for a correct and comparable operation in the lighting application.					
8	Median Useful Life (depreciation)	x	x	x	x		x
9	Abrupt Failure Value (failures)	x	x		x		x

Table 1: Product data directly linked to lighting application standards

In this section, the initial luminaire performance parameters (1-7) are described that can be used as input for lighting design calculations. The useful lifetime luminaire performance parameters (8-9) are described in the section “Lifetime considerations”.

Common examples of misrepresentation of performance data are:

- Luminous flux output for LED module being stated instead of the luminous flux output for the complete luminaire
- Data based on 25 °C operation temperature of the LED module or light source instead of data based on the actual operating temperature of the source inside the luminaire
- Operating power being based on just that of the LED module or light source instead of that consumed by the complete luminaire
- Incorrect comparison of power / efficiency between luminaires containing built in control gear and those using remote control gear
- A combination of incorrect input power and luminous flux output values resulting in inflated efficacy

Lighting Application Requirements Following CEN

When considering if a product is the best solution for an application we need to understand what should be calculated to ensure that the correct lit environment is created.

When requirements are specific to the given lighting solution within the application space, a lighting design needs to be performed. In that case the data requirements when considering a particular lighting product should be application driven and consider what information is required to ensure the lighting solution is correct for the application space. Any data that is not driven by the application requirements should be considered of secondary importance.

Table 1 shows, according to European standards, which product requirements are relevant for each application and which of these requirements can be fulfilled wholly by the product data and therefore can be specified on a product datasheet.

Key to the standards

- IEC 62722-2-1:2016 - Luminaire performance: Particular requirements for LED luminaires
- EN 12464-1:2011 - Light and lighting: Lighting of work places Part 1: Indoor work places
- EN 12464-2:2014 - Light and lighting: Lighting of work places Part 2: Outdoor work places
- EN 15193:2007 - Energy performance of buildings: Energy requirements for lighting.
- EN 13201-2:2015 - Road lighting Part 2: Performance requirements
- EN 13201-5:2016 - Road lighting Part 5: Energy performance indicators
- EN 12193:2007 - Light and lighting: Sports lighting

Lifetime Considerations

There are two relevant useful lifetime performance values to be considered related to “gradual” and “abrupt” luminous flux output degradation of a LED based luminaire.

Gradual luminous flux output degradation relates to the lumen maintenance of the light source in a luminaire. It describes how much of the initial luminous flux output of the light sources in the luminaire is available after a certain period of time. Luminous flux output depreciation can be a combination of individual LEDs giving less light and individual LEDs giving no light at all.

Abrupt luminous flux output degradation describes the situation where the LED based luminaire no longer gives any light at all because the system (or a critical component therein) has failed.

Both “gradual” and “abrupt” luminous flux output degradations have been described in the IEC lifetime metric for LED based luminaires. IEC suggests applying a standard set of quantities for communication to the market: “Median Useful Life” and the associated “Abrupt Failure Value”.

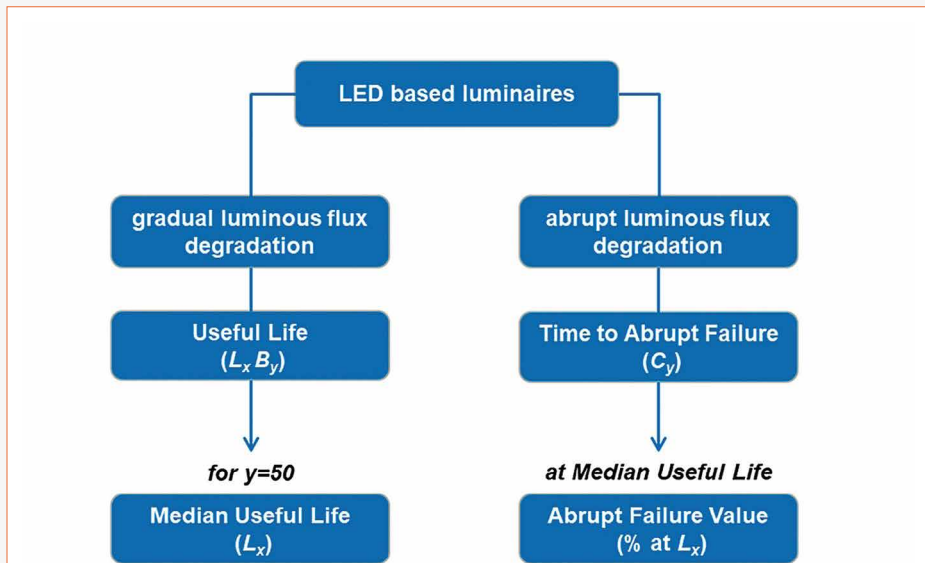

Figure 2: IEC lifetime metric

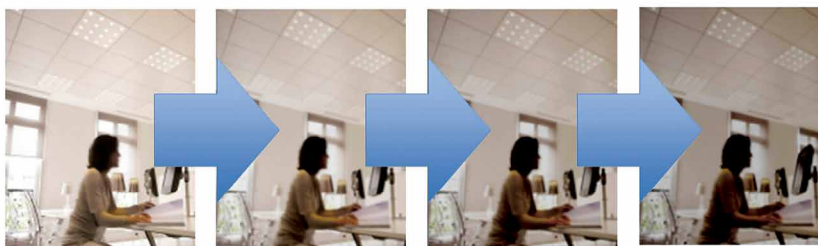

Figure 3: Gradual light output degradation

As the Median Useful Life of LED based luminaires can be very long, it is important to understand that useful lifetime performance values are predictions rather than measurements. For manufacturers, it is not possible to measure the useful lifetime values with, for example, 50.000 h before launching new products. Instead, the manufacturers use shorter assessment periods and extrapolate the results to arrive at predictions.

The IEC performance standards currently describe lifetime metrics for LED based products but not how to measure/calculate the parameter of the lifetime metrics. As a consequence, the quality of the lifetime predictions varies wildly and there is a significant risk of apple-to-pears comparison.

Reputable manufacturers will calculate Median Useful Life and associated Abrupt Failure Value based on historical design data and knowledge, component level testing and thermal design.

Lifetime data are normally specified together with a specific ambient temperature (t_q), the number of burning hours and the associated switching cycles.

Gradual Luminous Flux Degradation: Useful Life and Median Useful Life

The gradual light output degradation of a population of LED based luminaires at a certain point in time is called Useful Life and expressed in general as $L_x B_y$. The population includes operating LED based luminaires only; non-operative products are excluded.

Useful Life expresses the age at which a given percentile of LED based luminaires (y) cannot meet the lumen maintenance factor x . Light output lower than the required luminous flux maintenance factor x called flux degraded because they produce less light but still operate.

To unambiguously compare manufacturers' lifetime data, IEC introduced Median Useful Life (Lx). Median Useful Life is the time at which 50% (B50) of a population of LED based luminaires are flux degraded. Median Useful Life is generally expressed as Lx so without the B50 notification.

Example: Median Useful Life L90 is understood as the length of time during which 50% (B50) of a population of operating LED based luminaires of the same type have flux degraded to less than 90% (L90) of their initial luminous flux but are still operating.

Besides the median value (B50), in the market an apparent demand for B10 or even B0 rated products exists. Although By is a defined performance characteristic, the standard IEC 62722-2-1 does not include any technical explanation for how this parameter should be verified or applied.

Also lighting application design standards give no guidance for how a By factor should be accounted for. Closer technical evaluation as to what this really means is required.

It can be expected that around a distribution of products there will be a proportion above and a proportion below the rated performance value. The graph below shows an example of the normal distribution for a L90 rated product, illustrating the difference of a B10 or B50 value.

Detailed analysis of product data from LED based luminaires from various manufacturers shows that when projecting installation life up to 100.000 hours, the difference in flux degradation between B10 and B50 is about 1%.

For the L90 example at 100.000 hours this means that an initial luminous flux of 10.000 lumen will be 9.000 lumen in the case of B50. If the same luminaire is rated as B10, the corresponding value would be 8910 lumen. Bearing in mind that the rated light output data of both LED and traditional light sources are subject to a typical 10% tolerance this practical differential can be regarded as negligible.

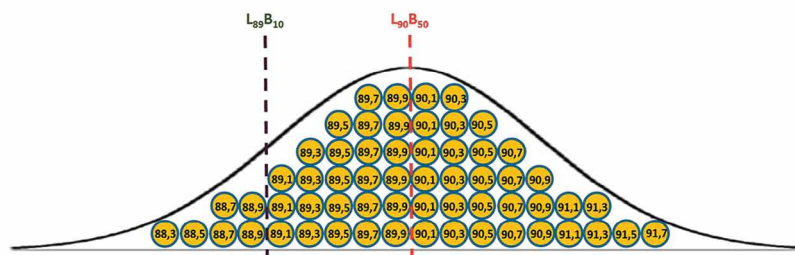

Figure 4: Example of normal distribution for a L90 rated product

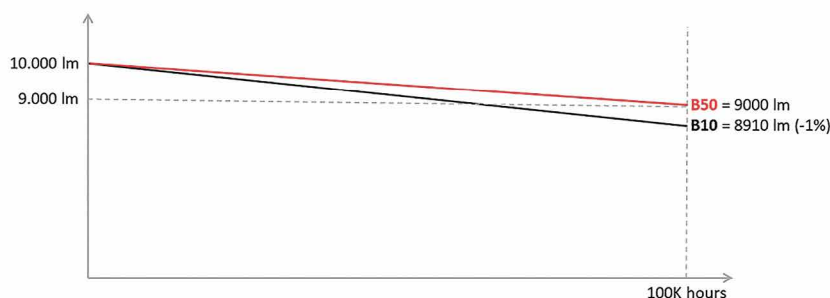

Figure 5: Product data analysis of an example of a LED based luminaire



Figure 6: Abrupt luminous flux degradation

As B10 and B50 are so close together, the spread due to depreciation is low and the median (B50) value represents with a sufficient degree of accuracy the lumen depreciation behavior of a number of products at the projected lifetime (in this example 100.000 hours). The measurement process for B50 is standardized and more widely accepted than any other By. Therefore, for reasons of accuracy and consistency between manufacturers the use of any other By cannot be recommended over the use of B50.

This indicates that for the commonly used L70, L80 or L90 values the By factor is not as significant as may be thought (or promoted) by some manufacturers and users. Consequently, there is little benefit in the

continued promotion of By as a significant factor for making product to product performance comparisons. Therefore only the Median Useful Life, generally expressed as Lx without the unnecessary B50 notification, should be promoted.

Abrupt Luminous Flux Degradation: Time to Abrupt Failure and Abrupt Failure Value

An important parameter that should be considered with expected long life is system reliability. A LED based luminaire will last as long as the component used with the shortest life. There are several critical components of a LED based luminaire that influence the system reliability.

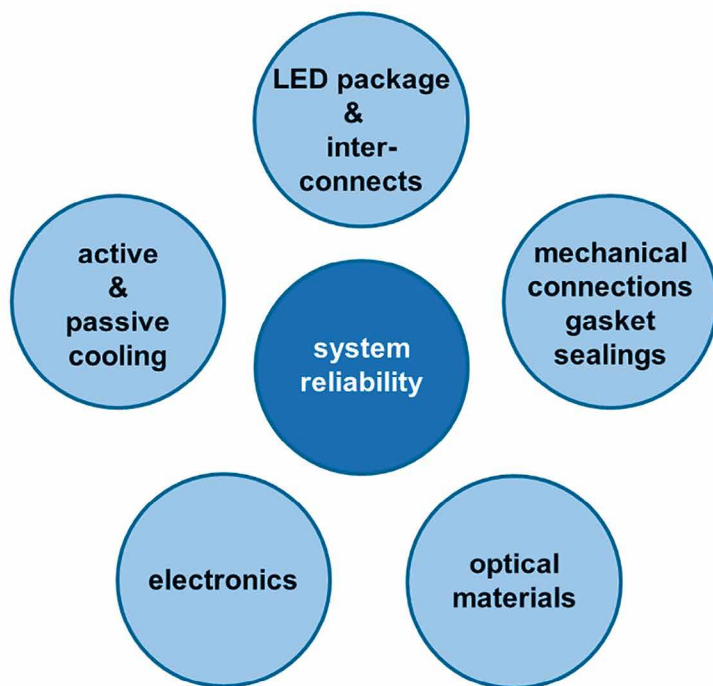

Figure 7: Principal components of a LED based luminaire

Degradation of optical material may cause a reduction of luminous flux rather than an abrupt degradation. Failure of one of the remaining principal components generally leads to complete failure of the LED based luminaire. This is not taken into account when indicating the rated Median Useful Life. For that reason, abrupt failures have to be considered separately so it can be taken into account at time of lighting engineering and planning. This is why the IEC lifetime metric also specifies time to abrupt failure, which takes into account failure modes of principal components in the LED based luminaire design.

The abrupt light output degradation of a population of LED luminaires at a certain point in time is called Time to Abrupt Failure and expressed in general as C_y . Time to Abrupt Failure expresses the age at which a given percentage (y) of LED based luminaires have failed abruptly.

To facilitate easy evaluation of manufacturers' performance data, IEC introduced the Abrupt Failure Value (AFV) of a population of LED based luminaires. Abrupt Failure Value is the percentage of

LED based luminaires failing to operate at Median Useful Life (Lx).

Example:

Abrupt Failure Value of 10% represents 10% of the population of initially operating LED based luminaires fail to produce any luminous flux at Median Useful Life.

The current IEC standards do not describe completely what failure modes of principal components to include in the Abrupt Failure Value (AFV) calculations. Since most of the abrupt failures in practice occur in relation to the LED control gear, LightingEurope recommends specifying the expected control gear failure rate of the device as the AFV indicated for the Median Useful Life of the LED-based luminaire.

Why Lifetime Is Not Always a Critical Factor

Looking at common practice, lifetime data for LED based luminaires seems to be a race for the highest number of hours belonging to the Median Useful Life L80B50. We have to be aware that in the professional market, requirements are

specific to the lighting solution within the application and a lighting design needs to be performed.

As input to the lighting design the average installation life is often given, so one could argue the highest number of hours is not a relevant discriminator when selecting a LED based luminaire.

Consequently, this justifies the question what is the best recommended value for comparing the useful life of LED based luminaires?

- Fixing of the "x" (lumen depreciation) from Median Useful Life Lx as a comparison value for different luminaires? In this case the "time" is not fixed and can have a variation from luminaire to luminaire
- Fixing of the "time" value from Median Useful Life Lx as a comparison value for different luminaires? In this case the "x" from Lx (lumen depreciation) is not fixed and can have a variation from luminaire to luminaire

To investigate the importance, the average installation life for different indoor- and outdoor applications have been calculated, based on the annual operating hours and the average time to refurbishment for a product in a specific application.

We also need to be aware that these values may not be realistic in all situations (e.g. in case of the use of automatic lighting controls or application requiring 24/7 illumination).

It can be concluded that for products used in the majority of indoor applications the average installation life will not exceed 50.000 hours. For products used in the majority of outdoor applications the average installation life will not exceed 100.000 hours.

LightingEurope believes that "number of hours" should not be a dominant discriminator when selecting LED based luminaires for professional applications. For the lighting design, the maintained luminous flux at the average installation life for a specific application is much more

Indoor applications	Default annual operating hours (EN15193)	Average time To refurbishment	Average installation life
	to	years	hours
Offices	2500	20	50.000
Education	2000	25	50.000
Hospitals	5000	10	50.000
Hotels	5000	10	50.000
Restaurants	2500	10	25.000
Sports	4000	25	100.000
Retail	5000	10	50.000
Manufacturing	4000	25	100.000

Table 2: Possible examples of average installation life for different indoor applications

Outdoor applications	Default annual operating hours (EN13201-5)	Average time to refurbishment	Average installation life
	to	years	hours
Street	4000	25	100.000
Tunnel (entrance)	4000	25	100.000
Tunnel (interior)	8760	12	100.000
Sport (recreational)	1250	20	25.000
Area	4000	25	100.000

Table 3: Possible examples of average installation life for different outdoor applications

relevant and may support energy saving through the reduction in over-design to account for losses through life.

LightingEurope therefore recommends:

- Lifetime claims should not exceed 100.000 hours, unless it is clearly required by specific lighting applications and verified by an appropriate life test period
- To enable apple-to-apple comparison it would be best practice to fix the “time” value for Median Useful Life to 35k, 50k, 75k and/or 100k and express the “x” from Lx (lumen depreciation) for time value(s) related to the applications where the product may be used

Maintenance Factor Consideration in Different Applications

With LEDs rapidly becoming the new standard in (functional) lighting design for both indoor and outdoor installations, the need has arisen to provide more clarity on how the existing CIE maintenance factor (MF) determination methods can be applied to this technology.

Clarification is needed to prevent unsafe and uncomfortable situations during the lifetime of the installation. Current CIE technical reports describing the MF determination methodology contain detailed explanations with respect to conventional

luminaires and light sources, but lack detail to accommodate LED-based lighting designs. However, the core of the CIE methodology - which is based on the same principles for both indoor and outdoor- is still accurate.

ISO/TC 274 is currently developing a Technical Specification that will provide a standardized way of working for determining the maintenance factor for both indoor and outdoor installations using the methodology as described in CIE 154:2003 & CIE 97:2005. Insights from recently published product performance standards such as IEC 62722-2-1 will be combined with the existing determination methodology from CIE technical reports.

By using the overall MF determination methodology and the content on the impact of the environment on luminaires in combination with the product performance metrics, a robust way of working can be established. This will allow for the determination of the maintenance factor of installations including the latest light source technologies. This will create a level playing field with respect to comparison of lighting designs in the market, provide clarity to all involved parties (from end-users to policy makers), and ensure safety and comfort over the lifetime of the installation.

Further LightingEurope Recommendations

Manufacturers of LED based luminaires should publish apple-to-apple comparable product information following the parameters and as described in IEC 62722-2-1.

Recommended initial performance values to be provided:

- Input power (P in W)
- Luminous flux (Φ in lm)
- Luminous efficacy (η in lm/W)
- Luminous intensity distribution (in cd or cd/klm)
- Correlated color temperature (T_{cp} in K)
- Color rendering index (CRI)
- Ambient temperature (t_q) related to performance of the luminaire (in °C)

Recommended over time performance values to be provided

- Lumen maintenance factor “x” (in %) at the associated median useful life Lx (in hours)
- Abrupt failure value (in %) at the same associated median useful life Lx (in hours). The expected “control gear failure rate” should be provided for this data

Lumen maintenance factor groups (buckets) should be introduced to enable initial product comparison. Separate product specific lumen maintenance factor values for input to lighting designs may also be published. ■

Lumen maintenance factor groups

Group value	≥70	≥75	≥80	≥85	≥90	≥95
Group range	70-74	75-79	80-84	85-89	90-94	95-100

Table 4: Lumen maintenance factor groups [1]

References:

- [1] Details on terms, their definitions and references can be found on the LightingEurope website. Also, application requirements from EN standards, divided into stated and implied requirements can be found there. - Please, visit <https://www.lightingeurope.org/images/publications/general/>

Disclaimer:

This information is for general guidance on matters of interest only. While we have made every attempt to ensure that the information has been obtained from reliable sources, LightingEurope is not responsible for any errors or omissions, or for the results obtained from the use of this information.

The content of this document is a recommendation only and is not binding to any party. LightingEurope members are not bound to adhere to this document.

All information is provided with no guarantee of completeness, accuracy, timeliness or of the results obtained from the use of this information, and without warranty of any kind, express or implied, including, but not limited to warranties of performance, merchantability and fitness for a particular purpose.

In no event will LightingEurope, its related partnerships or corporations, or the partners, agents or employees thereof be liable to you or anyone else for any decision made or action taken in reliance on the information or for any consequential, special or similar damages, even if advised of the possibility of such damages.

The data and information presented in this guide should not be taken as forming a basis of warranty conditions which are the responsibility of individual manufacturers.



LIGHTINGEUROPE
THE VOICE OF THE LIGHTING INDUSTRY

About LightingEurope

Who we are

LightingEurope is the industry association that represents the lighting industry in Europe. We are the voice of more than 1000 lighting companies who employ more than 100000 people over Europe.

Our daily mission is to advocate and defend the lighting industry in Brussels while reconciling it with ongoing EU policy aims. In doing so, we are dedicated to promoting efficient lighting practices for the benefit of the global environment, human comfort and the health and safety of consumers.

What we do

Our unique strength resides in bringing together leading industry actors with local and European policy experts in so called Working Groups (WG). These WGs are essential in our mission as they crystalize and often merge different viewpoints on burning lighting industry issues, hence paving the way for concrete policy steps.

Their output allows us to operate at the frontline of EU policy-making. Our WGs are nothing short of real entry points to the Brussels arena and merit your full participation!



Innovation in Light

Be Empowered

by Trends in Lighting.

What inspires you?

TiL is the unique, international “**Innovation in Light**” event, and is dedicated to bridging the gap between technologies and applications. Whether you are an architectural lighting designer, architect, industrial designer, healthcare innovator, advertising agency, automotive strategist, mobility designer, agriculture innovator, entertainment professional, education facility manager, project developer, urbanist, car designer, or investment consultants. *TiL* will reinvigorate your thinking about light in your industry. You will learn from the most compelling innovators, inventors and industry leaders.

Creating Value with Light. *TiL* is all about sharing talent and passion.

3rd International TiL Event
September 24–26, 2019, Opera House Bregenz

www.TiL2019.com

Tech-Talks BREGENZ - Guido van Tartwijk, CEO of Tridonic



Guido van Tartwijk

As Tridonic's chief executive officer, Dr. Guido van Tartwijk is responsible for Tridonic's day-to-day operations as well as leading the company's long-term strategy. He has more than 20 years of international experience in the semiconductor/LED electronics and lighting industry. Prior to joining Tridonic in November 2016, he was CEO of the LED Electronics section at Philips Lighting and held various senior executive roles at Philips Lighting in China and the Netherlands. Before moving to Philips Lighting he worked in several highly innovative start-up companies in both Silicon Valley and in Europe. He has a strong track record in leading and growing innovative teams and businesses across many geographies, and is deeply committed to driving sustainable long-term growth at Tridonic. Guido van Tartwijk holds an MSc in Physics from Eindhoven University of Technology and a PhD in Physics from the Vrije Universiteit, Amsterdam

Many traditional luminaire manufacturers are currently facing difficult times. LED professional discusses how this situation affects an electronics manufacturer with Tridonic's CEO, Guido van Tartwijk. The company's approaches to the hot topics of IoT, Smart Lighting, Human Centric Lighting, and Artificial Intelligence are discussed, including the underlying technologies. Light quality and the question of how time has changed this business, as well as the company's strategies for the future are all addressed.

LED professional: Thank you very much for taking the time for this interview.

Guido van Tartwijk: My pleasure!

LED professional: We were hoping to talk to you about Tridonic - what led up to Tridonic being in the good position that it is in, the challenges Tridonic faces and the opportunities for the future.

Guido van Tartwijk: Yes that would be great.

LED professional: Normally we start by asking for a history of the company, but I think this time it would be interesting if you told us a little about yourself.

Guido van Tartwijk: Well maybe I should just name some of the highlights. I have a PhD in physics - Initially, it was my ambition to be a scientist and a professor but I was tempted by the industry, and I joined the telecom industry in the late 90's. I was involved in developing hardware - making the products that would make the Internet possible. I worked in big companies and start-ups in the US and the Netherlands. I worked at start-up companies for around ten years in Silicon Valley and Europe and when the dot-com crash happened, I switched industries. I basically went from lasers to LEDs. I joined Philips in 2003 and because of my start-up background I was given the task of building up an LED lighting business in China. In 2015 my family and I came back from China and I felt that it was time for a change. I joined Tridonic at the end of 2016. So to sum it up: my background is small companies, big companies and always innovation, disruptive technologies and disruptive events in markets. I have worked in China, the US and Europe and even though I'm Dutch, I've spent a lot of time outside of Holland.

LED professional: You've had a very interesting life so far! But moving on to Tridonic - while the original business of Zumtobel was the magnetic ballast business;

today, the ballast business is driven by Tridonic. So I was wondering if you could give us a bit of the history of how Tridonic got to where it is today.

Guido van Tartwijk: I think that is a very interesting question because, as you say, Zumtobel is now the luminaire manufacturer. It's the company with expertise regarding lighting and lighting effects - the things that everyone can see. However, in every lighting solution there is something that is hidden in the ceiling or in the wall that also inspires electronics - the power conversion, the ballast, the electronic control gear. And that's basically how Tridonic was started. Initially, Wehn Zumtobel bought Tridonic in the 80ies, they transferred the whole ballast business to Tridonic who became the internal supplier of electronic ballasts. The nature of every electronics company is that you can only be competitive if you have enough volume. So very early - So very early - in the late 60's, Zumtobel decided to let Zumtobel Elektrobauteile (now Tridonic) sell its products to Zumtobel's competitors. And I think that was the defining moment in the history of Tridonic. Fast forward to today: Tridonic's products

have of course changed significantly from those produced 60 years ago but the concept is still the same: We sell 20% of our products to our internal customer - Zumtobel - and the other 80% is sold to Zumtobel's competitors. That's how you drive scale and volume and how you keep your costs at a relatively low level.

To ensure a good service for all our customers we treat both Zumtobel and all other customers alike. That is also why we are very careful to make sure that no pricing information and no customer information is shared between Tridonic and Zumtobel group's lighting brands - and for that we have installed what we call a "firewall". And it's that firewall and that discipline that are necessary to build trust with the market.

Over the past 60 years we have become a top 2 player in Europe and when it comes to indoor lighting Tridonic is the number one brand in Europe. That is a fantastic position!

LED professional: How do you manage that from a technical perspective? Are the products flexible enough for the client to program their own features?

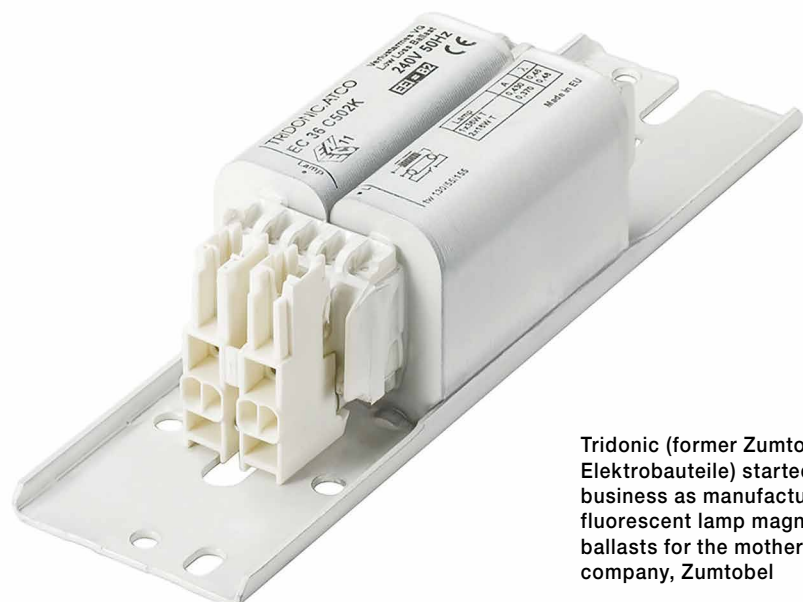

Tridonic (former Zumtobel Elektrobauteile) started its business as manufacturer of fluorescent lamp magnetic ballasts for the mother company, Zumtobel



Guido van Tartwijk spoke in detail about the business and impressed with his technical knowledge

Guido van Tartwijk: Every luminaire manufacturer wants to be different from their competitors. The key is that we enable them to be different. And there are many ways to do that: One is to provide custom-made products, which is difficult because you have to dedicate the products to one specific customer or sometimes even just to one specific project.

LED professional: That would work against scale...

Guido van Tartwijk: Yes; unless you work on the same platform.

A much more elegant way is to work with programmable features. So, if you make your converters programmable, a customer can tune whatever setting he or she wants. And that balance between allowing our customers to be different and at the same time standardise our products enough so that we can scale, that's the challenge for every ballast maker or component manufacturer. That is not easy. We are not like Apple; the iPhone is produced in high volume in China. We have, in total, more than 3,500 different products. So when you talk about high volume - that is relative.

We are constantly working on the portfolio to make it as streamlined as possible, while, at the same time, allowing our customers to differentiate. We do that with software; Tridonic started to integrate software into the products at a very early stage. If you look at our history you'll see that we produced magnetic ballasts in the late 50's. and in the late 70's launched the first electronic converters. In the very early 2000's we started what is now called the DALI protocol - the digital interface for lighting control. And that's where the software started to make its inroad into our products. Right now software accounts for almost half of our R&D activities.

LED professional: Before we dive deeper into the technology could you just give us some information about the company - how big is it and what are the figures?

Guido van Tartwijk: We just closed our financial year which shows that we had sales of more than €350 million, we are profitable, and we have a total of about 1,700 employees. Our headquarter is in Dornbirn, Austria. In Eastern Austria, in Jennersdorf, we have an innovation center and a factory which specialise in light sources. We also have a

sizable footprint in China with an innovation center and a factory in Shenzhen. In the U.K. in Spennymoor, which is in the northeast, we have an emergency lighting competence center and a factory. We have a small R&D presence in Switzerland where they specialize in sensors. We have about 60 sales offices across the globe - the ones most recently opened are in the U.S. and Malaysia. Before that, Tridonic wasn't present in the U.S. but as this is an interesting market and our brand has already been known there, we thought that we should also be present with our own sales offices.

LED professional: We'll talk about the market trends a little later, but for now could you tell us about your market strategy?

Guido van Tartwijk: Yes. We have a very strong presence in Europe - mainly in the UK and the DACH region (Germany, Austria and Switzerland). Our strength is growing in southern Europe, especially in Italy, Spain, France and the Benelux countries. Eastern Europe and Turkey are the fastest growing markets for us at the moment. The growth rate is in the double digits there. The reason for that is because Turkey and

Eastern Europe have become favorable places to manufacture products. So you see a natural focus of a lot of activities in Turkey and Eastern Europe. In the Middle East - we have had a very strong presence in Dubai for quite a while where we are a recognized brand. And we have a very strong presence in Australia and New Zealand. So Australia, New Zealand, Middle East, Europe are our key markets. We also have a presence in China with an R&D team and a factory in Shenzhen, in the south, and we have sales teams in Shanghai and Beijing.

LED professional: If we can focus on Eastern Europe for a minute: Tridonic is known for its quality and not being a cheap product. So how do you manage to compete in the countries in Eastern Europe?

Guido van Tartwijk: I don't like to compete purely on price, especially because Tridonic has a proven brand strength and that strength is based on a very good customer service, and a very good supply chain. We have a very strong customer focus. We don't just ask them what they want, but we also help them find what they really need. Sometimes we even go into co-development. Combine that with the supply chain that has recognized, top quality performance that is what allows us to ask for a premium. It doesn't mean that we feel comfortable and we can sit back and relax because you have to prove that point time and time again.

I should also mention that the Eastern European suppliers all want to export their products into Western Europe. That means that they have to meet certain quality standards. So it wouldn't be in their interest to switch to a no name brand, super low cost, non-proven supplier.

But again, I don't want to get too comfortable so I am always challenging our company to make sure we know exactly what the competition is doing, how they

are doing it and how we can serve the market even better..

LED professional: Looking back to the time of the fluorescent lamps, there was a big difference between dimmable and non-dimmable. Is this still an issue today or are all LED converters likely to be dimmable?

Guido van Tartwijk: It's surprising how many non-dimmable products there still are on the market. We still have a large volume of non-dimmable products. We all see, and we all believe, that LEDs will allow people to take full advantage of the benefits of remote control, dimming, tunable light. It's all there it's all true. But there is still a need for just light. And that need is big.

LED professional: So these are the real volume products...

Guido van Tartwijk: Yes, but with a high range of differentiation: different voltages, different currents, so its high volume as a group but as individuals, they are limited.

LED professional: Is there a reason for that?

Guido van Tartwijk: I think there is a lot of history in the market. If you look at the global field, there are

almost 10,000 luminaire manufacturers worldwide. It's a huge, scattered market. And it is not the fastest when it comes to adopting new technologies. So even though we are all very enthusiastic about LED and Tunable White and Human Centric Lighting and remote control, the fact of the matter is that the bulk of the market is still very slowly adapting to this new trend. So it will happen, but it will take years until all the non-dimmables are replaced by more fancy products.

In the past there was also quite a price difference between non-dimmable and dimmable but with everything becoming digital and software focused, the price difference is getting smaller. As for the market trend - I think people will only replace their lighting once - going from fluorescent to LED but they won't go dimmable. But the next time they go they'll ask for remote control and they'll want everything. So there are a few steps.

But it's remarkable in the sense that it takes the market a while to adopt. LED penetration almost took 15 years to get to a reasonable level. But you would be surprised at the number of non-LED converters we are still selling. We still have conventional converters and as long



While the competency for LED light sources is concentrated in Jennersdorf, electronics and intelligent systems are the domain of the engineers at the headquarters in Dornbirn

as customers want them in reasonable volumes, we will keep on making them. But we know it will stop one day.

LED professional: What percentage of your production are conventional converters?

Guido van Tartwijk: It's about 15% right now. It's going down rapidly, but I'm still surprised by the fact that in 2018 they are still needed. It means that people are still buying conventional products today and installing them.

LED professional: You mentioned the competence center in Jennersdorf, Austria where you produce Chip on Board and modules. This is just a small part of the Tridonic business, isn't it?

Guido van Tartwijk: No, it's not small at all. I think the interesting thing about the market is that in the past, Tridonic and its competitors only focused on the electronics box - the converters - because the light sources were quite chemical. The LED is also an electronic component: it's not the same but at least you have the same type

of production lines. So, as a natural step, we added that to our activities. And that requires a dedicated competence center - which is in Jennersdorf.

Today, our LED light source business is almost a third of the €350 million. And we can add a lot of value to customers by offering them a combination of a pre-checked, compatible LED module and a converter, in fact a "Bundle". The Bundle sales are actually very interesting. It helps customers because they don't have to go to two different suppliers, they don't have to figure out which converter they need for a certain module; you basically deliver a total package to them.

So that business in Jennersdorf has helped us a lot. Not only with the direct contribution of the modules but also the fact that we can sell the combination of drivers and modules.

If you look at the prices on the market, LED modules are most sensitive to price erosion. So I'm really happy that the Jennersdorf team has been able to keep up with competition, step by step.

It's quite challenging. And the only way we can differentiate ourselves from our competition is the fact that we are closer to our European customers. Jennersdorf is in Austria - which means that if a customer orders we can ship within 48 hours. It doesn't have to be transported by sea freight on a boat from China! The second thing is that people ask for special light-effects which we can provide due to our LED expertise. In essence, those are the two things that allow us to differentiate. But I also have to say that it's not the easiest business to be in.

If I may add one more trend - which is even more interesting: The fact that we have both the light source and the converter which are based on the same electronic principles made it possible to combine the two parts into one. The industry has been trying to do this since 2012. I believe I saw the first attempts in Frankfurt at Light + Building in 2010 or 2012. There were completely integrated engines with electronics and LEDs on one board. But they had all kinds of issues. They didn't dim. They were flickering. There was ripple.

Before digitalization, Tridonic mainly defined itself as a „fast follower“. Today the company aims to lead, at least in some key technologies, with products such as DCstring, net4more and TundableWhite

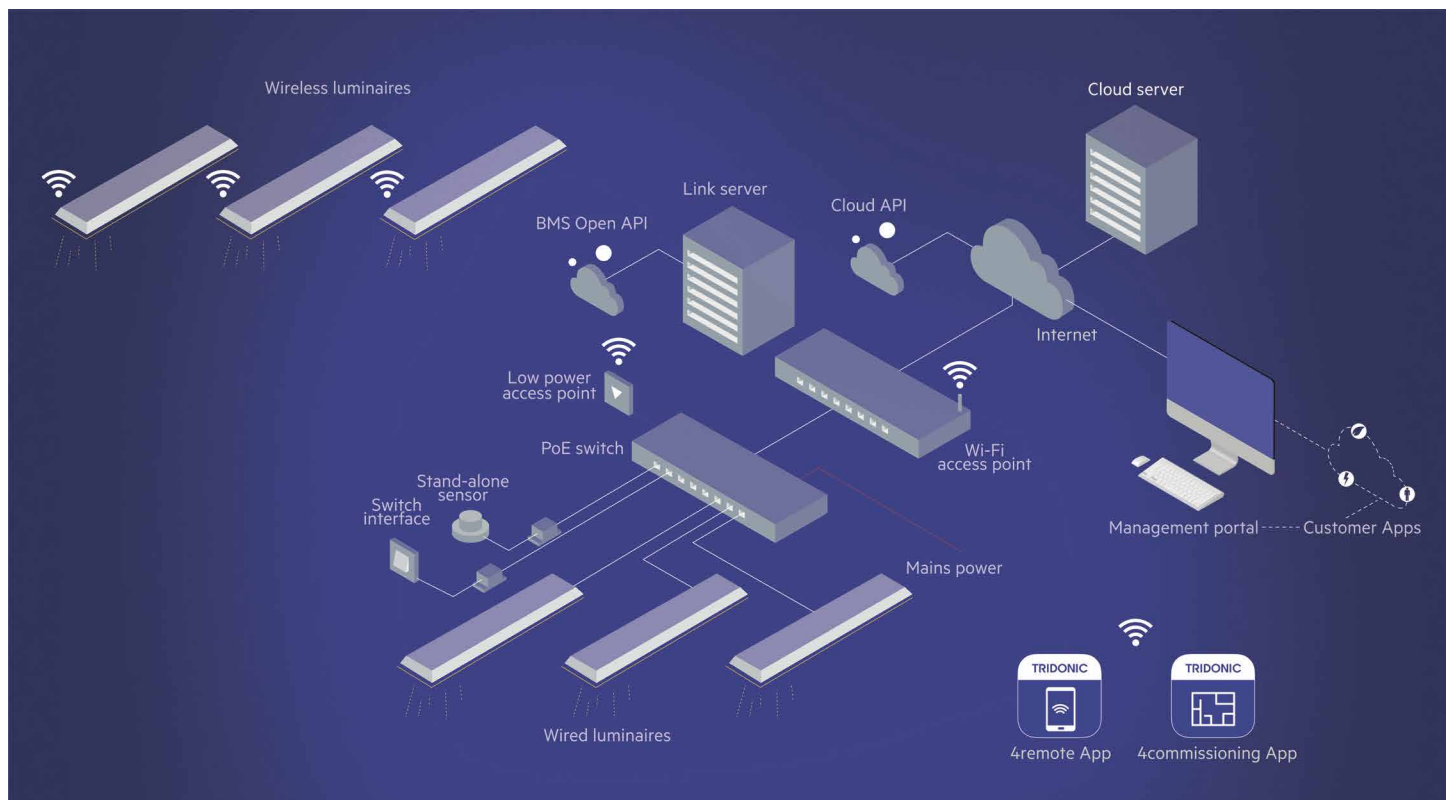

Those things have all been taken care of in the meantime but now the cost is the problem. We see in certain applications, like moisture-proof luminaires, where the luminaire has to be completely sealed, it's perfect to have integrated boards with the electronics for power conversion and the light source itself. And that's why it's essential to have that competence in house. I want to be able to innovate with those two ingredients.

LED professional: Looking back around ten years, when I talked with technicians from Tridonic they always said that they had good products and were at the top level but they were fast followers. Is that the same today?

Guido van Tartwijk: When LED started to take hold, the market started to become busier. The barrier for entry to the market is lower now. There are many more players around. There are very small companies as well as big companies, so it's a fight for speed, innovation and quality, reliability and the supply chain. And that's a very difficult mix. I think it's fair to say that we are leading in a couple of aspects in the portfolio but in a lot of aspects we are just the same as the big guys and the small guys who are just following the trend.

We have an aspiration of being the leader in a couple of key technologies, but it's tough. Right now, I think, with DCstring, net4more, and TunableWhite, we have something to show. It doesn't mean that no one else is doing something similar, but we were one of the first to embark on it. So on the important aspects, we have innovation programs but it would be naïve to think we can be the leader in everything.

LED professional: Today everybody is talking about connected lighting. About 20 years ago, connected lighting was easy - it was DALI. But today there are so many different technologies that I have to ask myself if it will be the luminaire maker that will integrate the Internet or will it be the Internet provider that integrates lighting. What is Tridonic's position?

Guido van Tartwijk: That's a very good question but I don't think we have a clear answer. I think the market today is exploring different versions of what you just described. But let me take a step back to the old world, without connectivity: Suppose our friends in Jennersdorf had made a fantastic, new Chip-on-Board module with unique phosphor and a fantastic color rendering. What would we have done? It would have gone to our luminaire customers and we would have asked them to try and design this thing in and use it in their products. But we would also have tried to talk to the end users about the product - tell them what we have - and then let them ask for it.

Now we move forward to the connected world: We have a full technology suite for connected lighting. The net4more toolbox provides both hardware and software as well as Apps, in fact everything that is necessary, to pave the way for lighting to enter the Internet of Things. But as you said, there are many, many different technologies out there. So what we do in terms of connected lighting is, instead of going to the end-user at the fashion store and telling them that their clothes will look much better with our product, we go to the IT department of big companies and explain them how we connect lighting into the Internet and let them ask for our technology.

LED Modules, Driver, Controls and Connectivity

Create intelligent buildings with integrated systems

Meet Us
at LPS
Booth C14



- **net4more an IP-based lighting system**
Monitor what the building tells you
- **Trusted outdoor solutions**
innovative, efficient, safe
- **Compact MSensor portfolio**
Fit for DALI-2

www.tridonic.com

TRIDONIC



Smart City World

We still sell our products to the luminaire manufacturers but some products need to be marketed directly to IT departments.

I believe there is going to be an unclear phase in the coming years and I'm expecting a new company to emerge in the market, which we call a contractor or system integrator. It's a company that will do the turnkey project for another company. What this company does is arranges all the luminaires, and arrange all the network components and deliver the project.

LED professional: It has always been a problem for luminaire manufacturers to sell more than luminaires. They've always had problems selling systems. So will it be the task of Tridonic to sell systems or will the luminaire manufacturers have to learn to sell systems?

Guido van Tartwijk: I think it's both. I think Tridonic also has to learn to talk about the value beyond the simple hardware box that you sell. So what we do is we enable our customers to become a system provider. Enabling means that we don't tell you how to do it but we give you the tools you need to do it. And the portfolio isn't just a collection of hardware boxes - it has software suites as well. So our customers can say, "Listen, I don't like the look of this app. I want you to change it; I want my name here and I want the dashboard to look different." Tridonic provides this flexibility. - But you're right - not everyone will be that quick. Some will be quicker than others. And I believe that is why things are so chaotic right now. At the

moment there are some luminaire manufacturers are still at the very early stage of understanding what the change to connected lighting entails. Some have a strategy to enter in the connected world. And there are other companies that aren't linked to a luminaire manufacturer who try to build a business by being independent. So it's pretty complex. Add to that at least five different technologies per application and you have a dangerous cocktail. And now the struggle for companies like Tridonic is how to choose.

That is why we have said that we will focus on two application domains: Connected lighting in a single room with a limited number of light points and the second one, net4more that is, would be for multiple rooms, multiple floors, full buildings and even multiple buildings on a scalable system. Those are the two applications we go after.

LED professional: I believe that many luminaire manufacturers are experiencing crises these days. Where is that coming from? Is it the new technology that they can't deal with? I've noticed that 20 or 25 years ago the luminaire business grew alongside the building business. But that's not happening today: even though there is a boom in the area of construction, luminaire business is in crisis.

Guido van Tartwijk: If you look at the global market and which countries have a positive GDP, and then you look at the construction industry which is booming, it is logical that there has to be a boom in the lighting industry. That used to be true in the past. But now what we see are flat, or even declining, luminaire sales in a very positive economy. The answer has to lie in the fact that apparently it is now easier to build luminaires and to be in that market than it was in the past. So the barrier to enter the luminaire market has been lowered. LEDs have contributed to the lowering of the barrier because it has become an assembly industry where you just wrap a suitable cover or a lens around the LED and you have a luminaire.

The reason for why we are growing so strongly in Eastern Europe and Turkey is that the amount of imported luminaires is phenomenal. So there is a supply surplus and the laws of supply and demand dictate that the prices are going in the wrong direction. And so, look at the volume being

sold -Tridonic sold a record number of LED drivers last year. And even the sales of a combination of LED modules plus driver is at a record high. So our factories have been very busy. The volume that is being shipped into these growing economies is increasing but the prices are declining faster than the volume grows and therefore everybody is struggling. We hope that this will stop but it requires the industry to have a shake-out. I think that when LED first started in the late 90's, a lot of people expected the lighting market to have a shake-out and it hasn't really happened. It has been almost 20 years now and we're seeing the first luminaire manufacturers getting into trouble. There have been a couple of bankruptcies in Germany during the past 12 months. And that's quite unique.

LED professional: Does the market even understand the difference in quality? I mean, the average person really can't tell the difference between good light and bad light. Therefore the luminaire maker can take the optics from one company, the LED from another and the driver from another, put it on a board, and it's finished.

Guido van Tartwijk: A lot of our efforts go into explaining to customers again and again that, for example, it is very important for us that there is no ripple. We are putting a lot of effort into delivering the message that there is a decent level of quality that you have to adhere to. But of course, many customers are tempted to try something below that level and if no one complains, they say it's good enough. And that's how the market goes down in terms of quality, appreciation and things like that. Luckily, in some markets there are very strict regulations regarding the quality of light. That's why even in Europe you see big differences. Some markets have a higher acceptance level than others. It requires a lot of education to make sure that our customers don't forget that if people are not excited about light, it's a missed opportunity.

LED professional: To wrap it up I'd like to ask you to imagine it's five or ten years in the future: What will lighting look like then and what will Tridonic's position be?

Guido van Tartwijk: In my opinion, in ten years, lighting will be in even more places than it is today. It will be in places that you don't expect it to be today. Right now we see it in ceilings and standing luminaires outside.

I think it will become more integrated in our living environments, both indoors and outdoors. It will be very versatile - meaning it will change its color temperature or intensity based on the needs of the people. I don't know about you, but I don't like touching remote controls and keyboards and things like that because it's boring. So I think that lighting will become part of artificial intelligence that will run buildings and cities, and basically adjust the lighting according to the needs of the people.

And where will Tridonic be 10 years from now? We will be one of the leading brands, globally, that will provide the ingredients for that network. Network doesn't mean you have to have a lot of communication between the light points. But light will become almost sentient. It will listen, see and then act according to what's happening. And it will require us to keep on innovating - building on our strong legacy - knowing how to convert 230 volts from the wall to the right voltage for LEDs, link it to sensors and controls and make it run as a whole. - That's the dream!

And it's a known fact that goes against the erosion of quality: people feel better and are noticeably healthier when they have proper lighting. And that is going to be the big trend - Human Centric Lighting based on Artificial Intelligence

But 10 years is a short period of time. We have a long way to go!

LED professional: Thank you very much for sharing your insights and your visions with us.

Guido van Tartwijk: My pleasure. ■

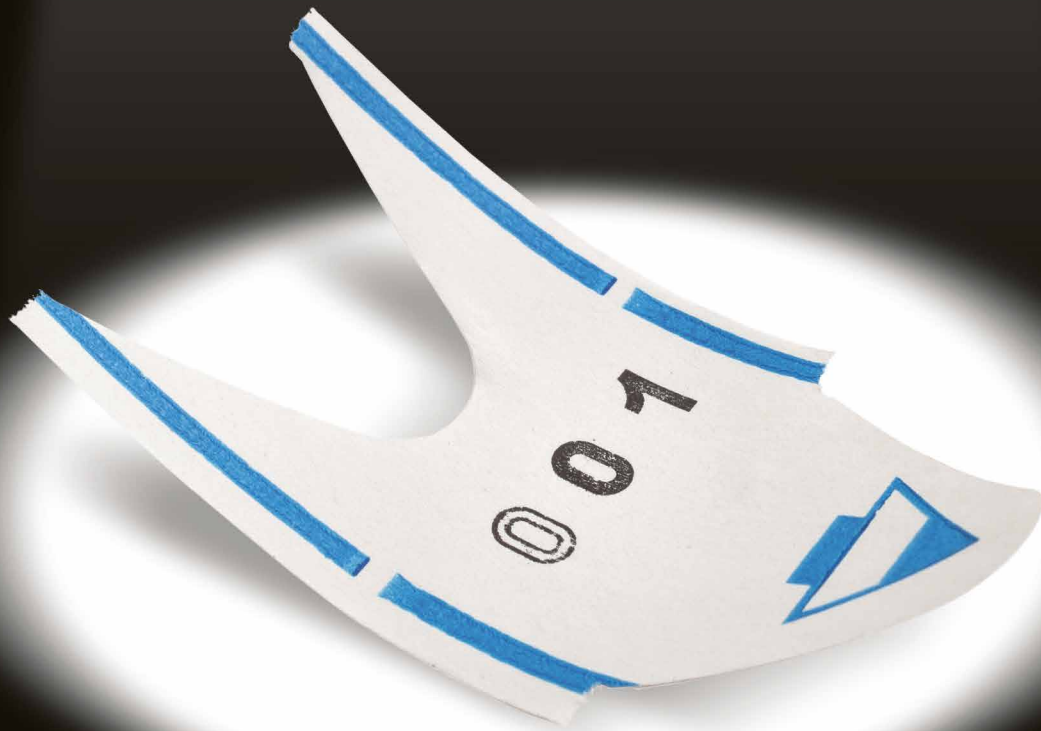

Never wait again...

Zero Lead-Time Program

Philips components, parts ship right away!

Contact your local FLS sales representative now.

www.FutureLightingSolutions.com/ZeroLT



www.FutureLightingSolutions.com



*Offer is based on certain marketplace assumptions and, as such, changes in the marketplace may invalidate this offer. Offer may end at Future Lighting Solutions' discretion at any time. Offer is valid in North America only. Please contact your local Future Lighting Solutions representative or visit www.FutureLightingSolutions.com/ZeroLT for details on this offer and its terms and conditions.

Smart Design of Freeform Micro-Optical Elements for Thin Direct-Lit Luminaires

Direct-lit LED luminaires consist of LED arrays. In order to achieve homogenous light distribution a diffuser sheet is placed at a certain height above the LED array. Usually the distance between the LEDs and the diffuser has to be greater than the distance between the LEDs on the array. To overcome this limitation, additional optical elements like freeform lenses are necessary. Christian Sommer, scientist at the Institute of Surface Technologies and Photonics of the Joanneum Research Forschungsges.m.b.H and his colleagues, Claude Leiner, Ladislav Kuna, Paul Hartmann and Franz P. Wenzl propose a smart design concept for an extremely flat, direct-lit lighting system, making use of mask-less laser direct write lithography.

Common LED based direct-lit luminaires for general lighting applications use LEDs as light sources, which are placed at a certain distance in a regularly arranged array. In order to achieve homogenous light distribution a diffuser sheet has to be placed on the out-coupling side at a certain height above the LED array. The required height is determined by the distance between the LEDs. For this so-called DHR (distance (of the LEDs) to height (of the diffuser sheet placement) ratio) values of 1 are hardly achievable. To overcome this limitation additional optical elements like freeform lenses are necessary.

In this contribution we discuss a smart design concept for an extremely flat, direct-lit lighting system. It is characterized by an improved distance (LEDs) to height (diffuser sheet) ratio compared to diffuser sheet only-approaches and a smaller thickness compared to common freeform approaches. For this demand we designed very thin freeform lenses with a maximal height of 60 μm that allow to maintain a uniform illumination in a flat direct-lit backlight using an LED-array with a comparably large distance between the individual LEDs. The concept emphasizes the use of mask-less laser direct write lithography for the cost-effective fabrication of the thin freeform micro-lens array.

Introduction

Light sources based on light emitting diodes (LEDs) have a lot of advantages in comparison with their conventional counterparts like incandescent or compact fluorescent lamps, which range from lifetime, reliability, energy saving to new potentials for system integration because of their compact sizes [1,2]. As a consequence, LED based luminaires nowadays have found their way into signage, display backlight, automotive lighting, general lighting and architectural lighting applications.

Still, research on LEDs and LED based luminaires has not come to an end yet and there are a lot of challenges ahead for the ongoing improvements of device efficiency, white light quality, but also luminaire design. In this regard, in the following we extend our previous discussion [3] on a design concept for a direct-lit luminaire for general and architectural lighting.

As discussed in [3], such a set-up for a direct-lit luminaire has a close relationship to the more recognized

direct-lit backlight for liquid crystal displays (LCD) used in the premium segment of television (TV) sets.

The possibilities for a homogeneous luminance and a very flat construction in combination with a large display size are the reasons why LED based light sources have become very attractive for the backlight unit (BLU) of LCD television sets. On the other hand, these potentials are also very appealing for a direct-lit luminaire aiming at general and architectural lighting applications. Usually, the LED light sources of a BLU are arranged in an array and the denser the LED dice are packed the higher is the uniformity of the irradiance on a target plane. Still, the packaging density is limited by the cost (due to a larger amount of LED dice needed with increasing density), the available space and thermal issues.

Therefore, research activities for the design of direct-lit BLUs on the one hand focus on large-scale uniform illumination, and on the other hand on an increased distance between the individual LEDs. The research of the last several years has investigated different LED arrangements and the superposed illumination/irradiance of the LEDs on a certain target plane, e.g., for achieving a homogeneous illumination for a rotational symmetric illumination of a single LED [4,5]. However, the optimal arrangement alone is not sufficient for achieving both a uniform illumination and a thin BLU. It is desirable that the ratio of the

distance between two LEDs and the height (or the thickness) of the BLU, i.e. distance-height ratio (DHR), is high. Increasing the distance between the LEDs of the regular LED-array by keeping the target plane at a constant height is only possible with additional optics. Several researchers have investigated freeform optics in this context [6-8]. The related strategies e.g., rely on a freeform optic for a single LED die which generates a uniform square shaped irradiance distribution with a certain width d . Using an array of individual freeform optical elements with such a configuration allows to generate a uniform irradiance distribution on the target plane, for example on a diffuser element, which transforms the uniform irradiance distribution into a uniform radiance. With such a concept, a large area backlight with a size of several square meters and a uniform luminance comprising a high DHR value of up to 3 can be realized.

These properties are what a direct-lit luminaire would make also very appealing for general and architectural lighting: Large size area, homogeneous luminance, high efficiency, a tuneable brightness, very thin height with a high DHR value. All these desirable properties of LCD displays are also valid for general lighting luminaires and can be derived from strategies developed in this regard. While the freeform optic generates the uniform irradiance at the target plane the diffuser sheet allows for angular mixing of the light so that a uniform luminance can be obtained.

High DHR values are desirable because for a specific area of the luminaire a lower number of individual LEDs would be needed, which reduces the costs and lowers the electrical power needed. On the other hand, when keeping the number of LEDs fixed, a higher DHR value allows decreasing the thickness of the luminaire facilitating its integration, e.g., into walls for indoor lighting.

In the following, we extend the discussion on our recently presented design scheme for calculating thin freeform optical elements with an effective height of about $60\ \mu\text{m}$ for a direct-lit luminaire with a high DHR value and an effective height of 10 mm, i.e. height of the target plane relatively to the LEDs. In particular, we discuss non-rotationally symmetric FF elements, which are of relevance in order to avoid the overlapping of the irradiance distributions of the individual elements.

Figure 1 summarizes the direct-lit luminaire concept with a thin FF element for achieving a homogeneous irradiance on the target plane where a diffuser sheet is placed, as discussed in our previous publication.

Freeform Design Procedure

The design procedure for the freeform (FF) optical elements used in this contribution has been published in more detail elsewhere [3]. Briefly, it is based on a two dimensional approach by applying Snell's law in a ray mapping

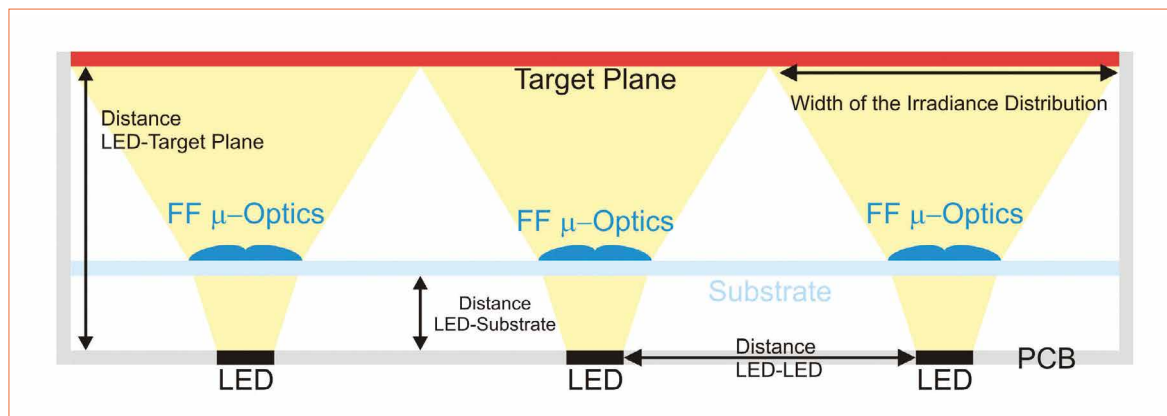
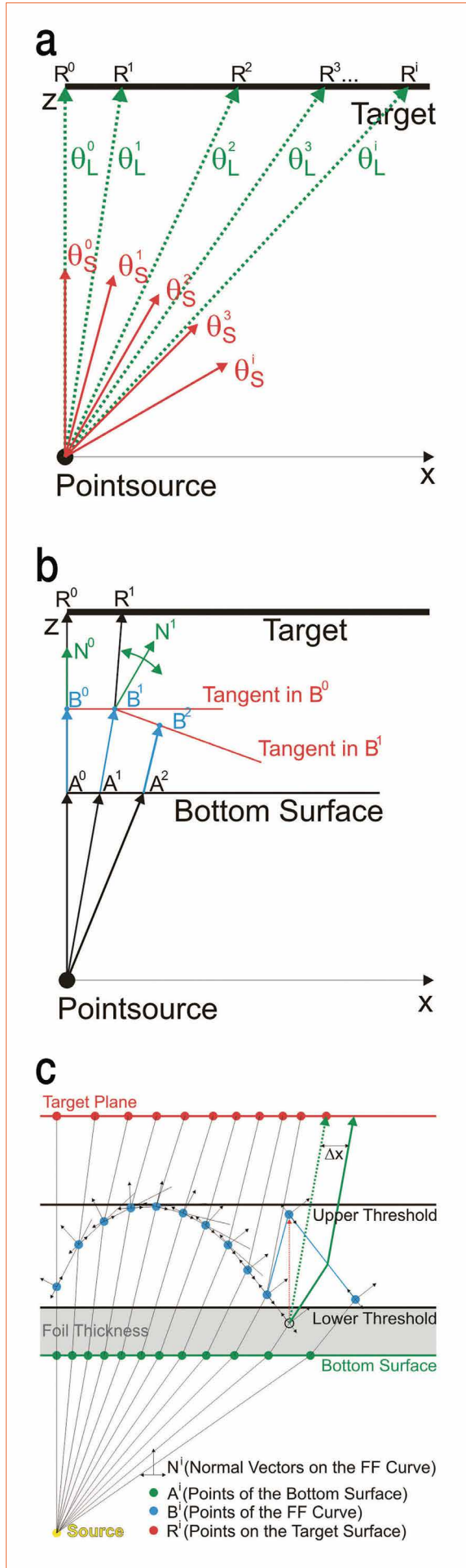

Figure 1: Schematic of a direct-lit luminaire concept with flat freeform optics for achieving a homogeneous irradiance on the target plane, at which a diffuser sheet is placed

Figures 2: Illustration of the discretization of the radiant intensity distribution $I_s(\theta)$ of the source (a). Scheme of the sequential FF algorithm to calculate the points B^i and A^i , which are determining the top and the bottom curve of the FF element (b). Schematic illustration of the functionality of the implemented transformation algorithm when a point B^i falls below the lower threshold value (c)



scheme, which is outlined in figure 2. The FF algorithm enables the determination of a complex optical surface in a sequential process, which allows to transform an arbitrary angle dependent radiant intensity distribution $I_S(\theta)$ of a light source into a calculated angle dependent radiant intensity distribution $I_L(\theta)$ which is generating the desired irradiance distribution when illuminating the target plane [8]. In other words, the ray mapping scheme correlates rays emitted by the light source with calculated points R on the target plane (Figure 2a). This allows the design of an optical surface which refracts the emitted rays towards the calculated points R (Figure 2c).

In order to find an optical element which is capable to fulfil this condition, the radiant intensity distributions $I_L(\theta)$ and $I_S(\theta)$ are discretized into M rays with different propagation angles θ_L^i and θ_S^i respectively, with $i = 1, 2, \dots, M$. By this, the points R^i on the target plane can be determined (Figure 2a). The rays emitted from the source must hit these points to create the desired irradiance distribution on the target plane. The points B^i , which are defining the FF surface, are calculated in a sequential process by determining the surface normal vectors N^i in a way that, according to Snell's law, the rays are refracted towards their corresponding points R^i on the target plane (Figure 2b). After defining the A^0, B^0 and N^0 as starting parameters the sequential process is composed of three iterative steps (Figure 2b).

The three iterative steps from figure 2b:

- Determining the position of the point A^i by intersecting the i -th ray with the bottom surface and calculating the change of the propagation direction by Snell's law
- Determining the position of the Point B^i by intersecting the tangent corresponding to the point B^{i-1} with the actual ray refracted at point A^i
- Calculating the normal vector N^i in B^i in a way that the actual ray refracts towards the point R^i on the target plane

In order to create very thin FF lenses, we implemented an additional transformation algorithm directly in the sequential process of calculating the FF curve, which allows us to design flat FF lenses by defining two threshold values which define the minimal and the maximal height of the B^i points. The distance between the bottom surface and the lower threshold value therefore corresponds with the thickness of the thin foil (Figure 2c) and the distance between the lower and the upper threshold values defines the height of the FF structure. In case that the height of a point B^i drops below the lower threshold value during the sequential process, the height is artificially adjusted and the sequential process is continued with the adjusted point B^i (Figure 2c). With this measure the calculated FF elements can be restricted to a very flat design (e.g. a maximum of $60 \mu\text{m}$), which can be fabricated on a thin foil and enables the use of cost-effective

manufacturing methods like gray-scale laser lithography for mastering and roll-to-roll processing for large area manufacturing of the optical elements.

The determined points A^i and B^i are defining a bottom and a top profile of the FF lens and can be transformed into a three dimensional (3D) object by rotating the profile around the perpendicular z axis for 360°. However in this way only rotationally symmetrical irradiance distributions can be generated on the target plane. In order to extend this concept to irradiance distributions with a rectangular shape the 3D FF object has to be “segmented” into different slices with a constant azimuth step size α .

In figure 3 the process for creating such a segmented FF element for a non-rotationally symmetrical irradiance distribution is illustrated. The shape of the irradiance distribution is divided by a pre-defined number of swept profiles into different slices. The length of the slices depends on the shape of the irradiance distribution and the number of slices depends on the segmentation angle α . In the next step the FF algorithm is conducted for every slice separately, creating different FF curves for each slice. Rotating these different FF curves around the center (by the azimuth step size α) allows to generate 3D segments of the FF object. After the last step the whole FF object is composed of these different segments.

Results and Discussion

In this section Ray-Tracing (RT) simulation results of different FF elements are shown to illustrate the design concepts discussed in section 2.

Figures 4a, 4b and 4c show the top view of flat FF elements composed of 98 segments. These FF elements are designed to generate a square shaped irradiance distribution on a target plane in a distance of 10 mm, using a $0.5 \times 0.5 \text{ mm}^2$ LED chip with a Lambertian radiant intensity

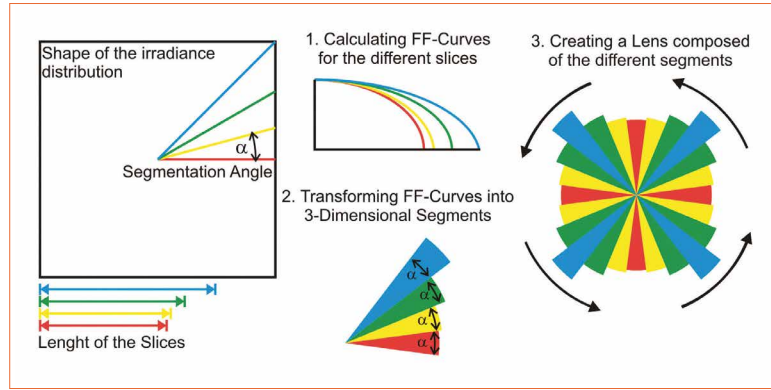
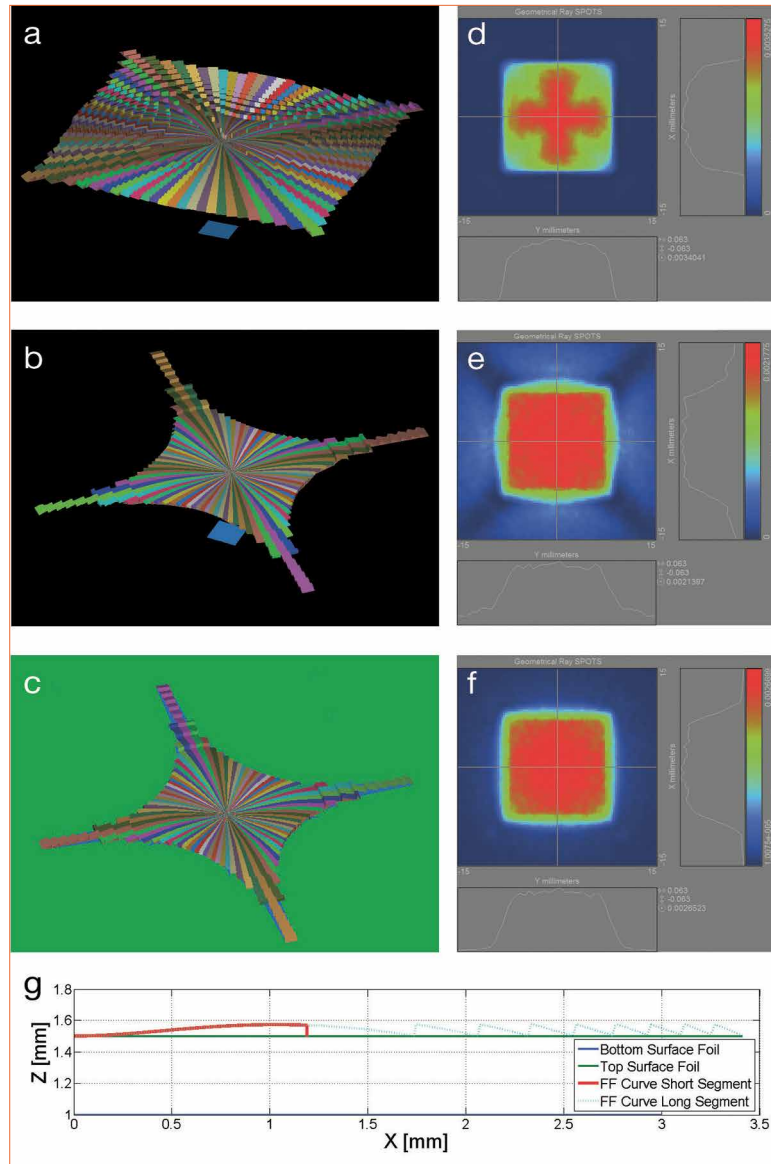

Figure 3: Schematic illustration for creating a 3-dimensional FF element that gives reason for a rectangular irradiance distribution on the target plane



Figures 4a-g: 3D Model of a flat segmented FF element (98 segments) designed for generating an irradiance distribution with a square shape on a target plane (a). Corresponding irradiance distribution on the target plane, determined by RT simulations (d). 3D Model of a flat segmented FF element (98 segments) designed for generating a uniform irradiance distribution with a square shape on a target plane (b). Corresponding irradiance distribution on the target plane, determined by RT simulations (e). 3D Model of the flat segmented FF element (98 segments) used in b with the FF element placed on a diffuser foil (c). Corresponding irradiance distribution on the target plane, determined by RT simulations (f). Cross section of the shortest and the longest segments of the flat segmented FF elements of b and c (g)

distribution. The FF elements are considered to be placed on a 0.5 mm thick foil with a refractive index of 1.517 and a distance of 1 mm between the bottom surface of the foil and the emitting area of the light source.

Figure 4g shows a cross section of the foil (bottom surface blue line,

top surface green line) of the foil as well as the calculated FF curves of the shortest (red line) and the longest (dotted blue line) of the segments of the FF element shown in figures 4b,c.

Due to the transformation algorithm applied in order to maintain a very low height, the calculated segments

Figure 5:
Schematic sketch of the direct-lit luminaire showing the arrangement of the relevant components and the dimension of the box

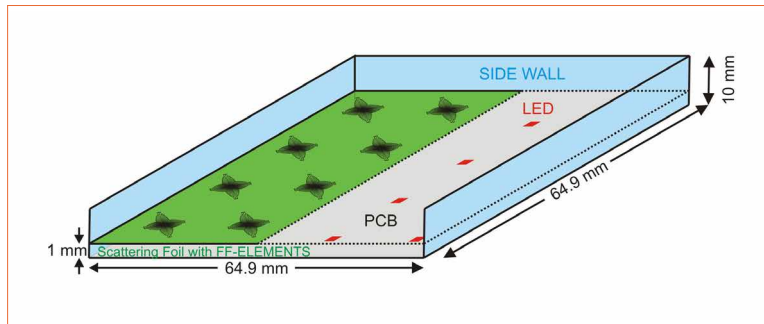

Figures 6a&b:
Simulation result of the irradiance distribution on the target plane using the diffuser foil with FF elements (a). Simulated irradiance distribution on the target plane without any optical element (b)

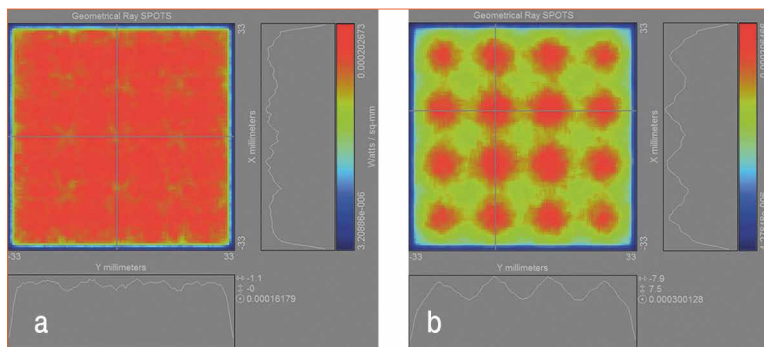

of the FF elements are showing a different number of “teeth” depending on how many times the curve dropped below the lower threshold value during the sequential calculation process. However, due to the transformation algorithm the maximal thickness of the different segments is not surpassing $60\ \mu\text{m}$ (Figures 4a-c).

The FF algorithm applied is based on a two dimensional approximation. For this reason the FF elements can only affect the θ propagation direction of the rays. On the other hand the individual segments are redistributing the same radiant intensity of the light source on different areas due to the different lengths of the slices, which causes an inhomogeneous irradiance distribution (Figure 4d).

To encounter for this issue, the amount of radiant intensity collected by each segment was adjusted in a way that each segment generates the same absolute irradiance value on the target plane (Figure 4e). Figure 4e shows the irradiance distributions (determined by RT simulations) on the target plane, generated by the FF element of figure 4b. As one can see, due to this correction, the FF element is generating now uniform

irradiance distributions within the target area. On the other hand, the amount of radiant intensity which is not collected by the FF elements is causing an unwanted intensity distribution outside of the target area (Figure 4e), which will affect the neighbouring intensity distributions when using the FF elements in an array.

To encounter this issue, the FF element of figure 4b was placed on a diffuser foil (Figure 4c) having a Lambertian scattering properties in order to redistribute rays which are not refracted at the FF element randomly on the target plane. Directly beneath the FF elements, the foil has no diffusing properties. As one can see from figure 4f, which is showing the simulated irradiance distribution on the target plane, the diffuser foil is redistributing the unwanted intensity distribution outside of the target area. In order to show the capability of this approach for a direct-lit lighting application, 4×4 FF elements in accordance with the design of figure 4c were arranged together in a square shaped array on a scattering foil which has a thickness of $0.5\ \text{mm}$.

In figure 5 illustrates a simulation model of a $64.9 \times 64.9\ \text{mm}^2$ direct-lit luminaire box with a height of

$10\ \text{mm}$. The top side, the front side wall and one half of the scattering foil were made transparent in the illustration, to facilitate the understanding of the geometrical arrangement of the different optical components of the simulation setting. The bottom side of the luminaire box is composed of a printed circuit board (PCB) with a square shaped LED array. The surface of the PCB was considered to be covered with a resist that has Lambertian scattering properties (reflectivity 85%) for incident rays.

The scattering foil with the FF elements is placed in a distance of $1\ \text{mm}$ from the LEDs. The arrangement is in a way that the centers of the FF elements are aligned with the centers of the single LED surfaces to generate a uniform irradiance distribution on the top surface of the box, which is placed $10\ \text{mm}$ above the light sources. The dimensions of the LED dice were chosen to be $0.5 \times 0.5\ \text{mm}^2$ with Lambertian radiant intensity distributions. The distance between the LED dice as well as the FF elements were set to be $16.2\ \text{mm}$, resulting in a DHR of 1.62 for the simulated direct-lit lighting application.

Figure 6 shows the simulated irradiance distribution on the target plane for this simulation setting with (Figure 6a) and without (Figure 6b) the scattering foil with the attached FF elements. As one can see the irradiance distribution generated with the scattering foil containing FF elements shows a very good degree of uniformity on the target area. figure 6b shows a reference simulation of the direct-lit luminaire assuming that no optical elements are applied between the light sources and the top side of the box. The irradiance distribution of the reference simulation clearly shows intensity peaks at the positions of the light sources and would give reason for an inhomogeneous radiance distribution of the direct-lit luminaire box.

Conclusions

In this contribution a two dimensional FF approach for calculating thin FF elements for lighting applications, e.g., for the use in direct-lit luminaire boxes, was presented. The proposed FF algorithm allows the calculation of FF elements refracting the radiant intensity of LEDs into uniform irradiance distributions with arbitrary shape. Furthermore a threshold value was included in the calculation algorithm enabling the control of the maximal height of the calculated FF elements.

In this way it was possible to calculate a FF element with a thickness of about 60 μm redistributing the radiant intensity of a $0.5 \times 0.5 \text{ mm}^2$ LED light source into a square shaped irradiance distribution on a target plane in a distance of 10 mm. By arranging 4×4 of these FF elements in a shaped array on a scattering foil with a thickness of 0.5 mm a direct-lit luminaire box with a DHR of 1.62 was simulated which showed an irradiance distribution with a very good degree of uniformity on the top side. A direct comparison with a

simulation of a direct-lit luminaire box without any optical elements between the light sources and the top side of the box indicated a clear improvement in terms of uniformity of the irradiance distribution for the given DHR value of the box by the use of the FF elements. On the other hand the presented design concept of such thin FF elements enables the use of cost-effective manufacturing methods like gray-scale laser lithography for mastering and roll-to-roll processing for large area manufacturing of the optical elements. ■

Acknowledgements:

The authors gratefully acknowledge financial support from the BMFWF within the Research Studio Austria program of the Austrian Research Promotion Agency (FFG), project number 844742.

References:

- [1] Schubert, E. F., "Solid-State Light Sources Getting Smart," *Science* (80-.). 308(5726), 1274-1278 (2005)
- [2] Craford, M. G., "LEDs for solid state lighting and other emerging applications: status, trends, and challenges," *Proc. SPIE* 5941(c), 594101-594101 - 10 (2005)
- [3] Leiner, C., Nemitz, W., Schweitzer, S., Wenzel, F.P., Sommer, C., "Smart freeform optics solution for an extremely thin direct-lit application," *Proc. SPIE* 9889, 988911-988911-11 (2016)
- [4] Qin, Z., Wang, K., Chen, F., Luo, X., Liu, S., "Analysis of condition for uniform lighting generated by array of light emitting diodes with large view angle," *Opt. Express* 18(16), 17460-17476 (2010)
- [5] Whang, A. J. W., Chen, Y. Y., Teng, Y. T., "Designing uniform illumination systems by surface-tailored lens and configurations of LED arrays," *IEEE/OSA J. Disp. Technol.* 5(3), 94-103 (2009)
- [6] Wu, R., Zheng, Z., Li, H., Liu, X., "P-63: Optimization Design of Irradiance Array for the Direct-lit LED Backlight," *SID Symp. Dig. Tech. Pap.* 43(1), 1299-1301 (2012)
- [7] Bin, X., Run, H., Luo, X., "Design of a brightness-enhancement-film-adaptive freeform lens to enhance overall performance in direct-lit light-emitting diode backlighting," *Appl. Opt.* 54(17), 5542-5548 (2015)
- [8] Hu, R., Zheng, H., Ji, C., Liu, S., Luo, X., "A method to design freeform lens for uniform illumination in direct-lit led backlight with high distance-height ratio," 2012 13th Int. Conf. Electron. Packag. Technol. High Density Packag., 1474-1478, IEEE (2012)



Accurate Calculation of the CIE Unified Glare Rating: SpecWin Pro Spectral Software

The spectral analysis Software SpecWin Pro from Instrument Systems calculates unprecedented accurately all optical parameters from the measured spectra. With the goniometer module angle dependent spatial radiation characteristics of LED luminaires can be determined. New goniometric reports present reliable unified glare rating evaluation in conformity with most recent recommendations in CIE 117.

www.instrumentsystems.com



Optical Designs to Improve LED Lighting Efficiency of Medical Endoscopes

Lighting efficiency for endoscopic instruments has been deemed very poor, at only about 20%. While laboratory tests demonstrate that fiber optics bending is not problematic, optical simulations clearly show that lighting efficiency is strongly limited by the Étendue. Because of strong geometrical constraints in the light coupling area of an endoscope system, only a radical new optical design can provide significant improvement. Alexander Gaertner and Paola Belloni from the Faculty of Mechanical and Medical Engineering and the Steinbeis Transferzentrum Lichttechnik und Beleuchtungsoptik at the University Furtwangen discuss these issues and propose possible approaches.

Figure 1: The typical illumination optics of a rigid endoscope: a fiber optic cable, a cone-shaped optics and a fiber bundle in which single glass fibers are embedded into a light absorbing adhesive. The dimension of a single fiber optics is in μ -range, the fiber bundle has a diameter of a few mm

The presented work focuses on the improvement of the degree of efficiency of the illumination optics of rigid medical endoscopes to provide more light in the surgeon's field of view and therefore better image quality. At first, the photometric and colorimetric properties of typical external LED light sources that power state-of-the-art endoscope systems were measured. Further measurements of the efficiency of the whole endoscope systems surprisingly showed very low values of about 16%-

19%. Both the endoscope's geometrical components as well as the critical optical interfaces have been implemented in a 3D-optomechanical-simulation model. By means of optical simulations we developed alternative optical components inside the endoscope to optimize light collimation to the target surface. The optimization takes into account both spectral and angular light distribution of the external LED light source as well as material absorption caused by manufacturing processes.

The investigations showed that because of the physical constraints given by the Étendue, a significant improvement of the efficiency of typical rigid endoscopes can only be achieved by radically changing the geometries and the mechanism that allow light transport and outcoupling.

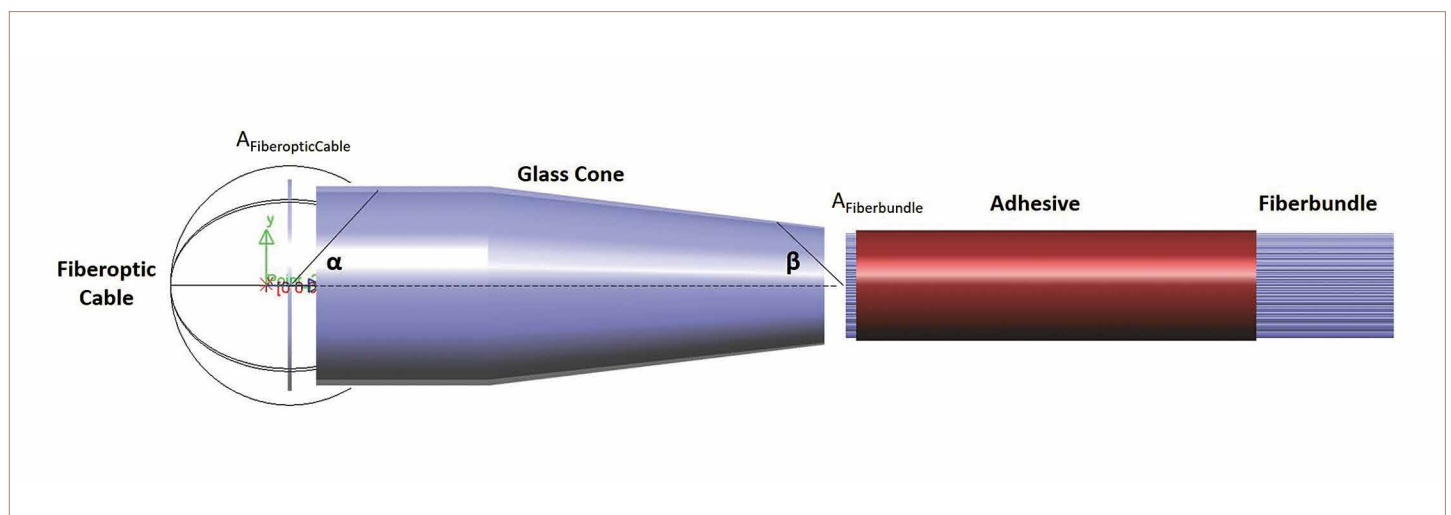

Introduction

Over the past years, endoscopes have become an essential part of minimally invasive surgery and, nowadays, are indispensable in operating rooms. Especially illumination has always been a great challenge for every type of endoscope and is now more important than ever, since endoscopy systems become smaller and more complex. Each endoscope is provided with an illumination optics that guides light from an external light source to the distal end of the endoscope and an imaging optics that captures reflected light from the surgical field and guides it to the proximal end to further images processing.

We distinguish between rigid, flexible and newly developed capsule endoscopes. In capsule endoscopes, illumination is realized by integrating LEDs that directly illuminate the field of view [1]. However, integrating LEDs in rigid and flexible endoscopes present challenges with respect to heat dissipation in order to be compliant with the strict regulations regarding temperatures and electrical safety of medical equipment as defined in the

European normative DIN EN 60601 [2]. Recently KARL STORZ introduced a Uretero-Renoscope with LEDs integrated in the handle [3]. But up to now, an integrated LED-illumination is not state of the art yet and the actual light source is placed outside the endoscope in an external unit.

Figure 1 describes in a schematic way the illumination optics components integrated into a rigid endoscope. An external light source is connected to the endoscope via a fiber optic cable with a typical diameter in mm range. From there, the illumination optics typically consists of two components: a small cone-shaped optics and a fiber bundle in which single glass fibers are embedded into an adhesive. Light is coupled from $A_{\text{FiberOpticCable}}$ under an angle α into the glass-condensing cone and is coupled out under a range of angles that depends on the collimation properties achieved. But only rays that hit the surface $A_{\text{Fiberbundle}}$ inside the acceptance angle β of the glass fibers are transferred to the distal end of the endoscope to finally illuminate the field of view of the surgeon.

Analysis of LED-Light Sources and Endoscopes

The first step of our optimization approach is the photometric and colorimetric analysis of external LED-Light sources. The results obtained are thus implemented in the optomechanical simulation model developed with LightTools (Synopsys©) and further considered in the optimization procedure.

Therefore, at first the illuminance values of state-of-the-art external LED-light sources in the lighting technology laboratory was measured. All fiber optic cable measurements were carried out with an integrating Ulbricht sphere ($D=25$ cm; Instruments systems) and a goniophotometer with integrated spectrometer for angular dependent spectral measurements (Czibula and Grundmann).

All measurements are performed according to DIN EN 13032-4 [4].

Most of the LED-light sources show the typical phosphor-converted white light spectrum with a CCT between 4600 K and 6100 K and the expected angular dependence of spectral properties. But quite

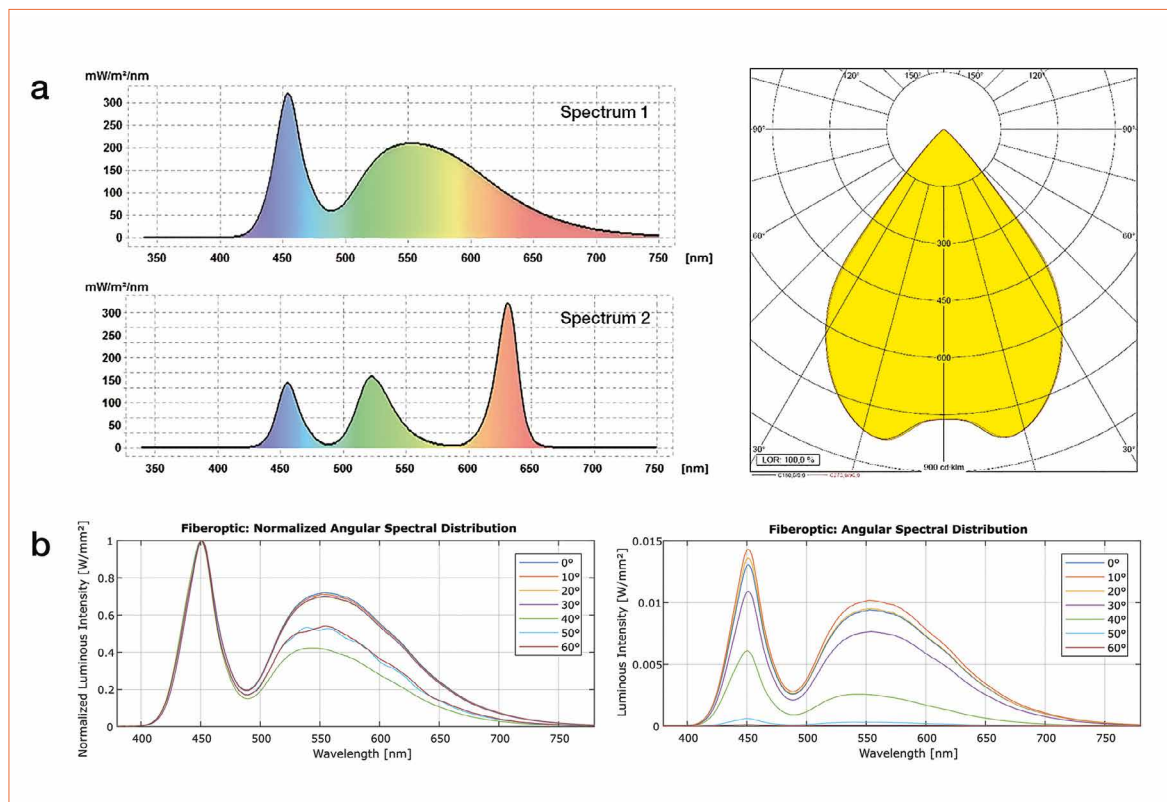

Figures 2a&b: Examples of the LED-light sources properties measured at the fiber cable end. (a) Spectrum 1 shows a typical phosphor-converted white LED with a CCT=5600 K whereas Spectrum 2 is an RGB system. Angular distribution curve of the light output, showing a maximum aperture/cut off angle of $\pm 36^\circ$. (b) The graphs show the angular dependent spectral properties of Spectrum 1

Figure 3: Illuminance losses that occur when connecting one representative external LED-light source (green bars) to three endoscopes of leading OEMs (blue bars). Measurements are performed at different intensity levels

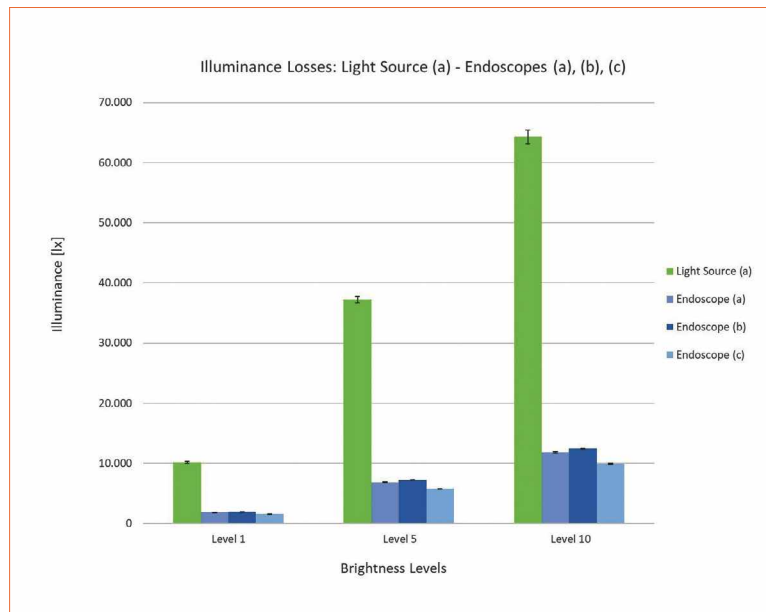

surprisingly one spectrum is an RGB system. All angular distribution curves measured at the fiber optic cable end are rotationally symmetric and show a cut-off angle. This is an important parameter for optimizing the illumination optics in the optomechanical simulation model.

Thus, the external LED-light sources were connected to three different endoscopes of leading OEMs in the medical sector and measured the illuminance values. The external light sources are typically adjustable to different brightness levels in order to better suit the specific needs of the surgeon.

The following three brightness levels were analyzed:

- Level 1 (minimum)
- Level 5 (mean) and
- Level 10 (maximum)

Each measurement was repeated 10 times and over a period of 1 hour with measurement intervals of 5 minutes.

Figure 3 clearly demonstrates that very high illuminance losses occur when the external light source is connected to the endoscope systems. Indeed, all the endoscope systems examined in this study reveal a total degree of efficiency of only 16%-19%. The degree of efficiency of an endoscope is defined here as a ratio between

luminous flux out of the endoscope relative to that of the fiber optics one.

Moreover, it has to be considered that this result is not specific for the external light source shown in figure 3. In fact, an analysis of other standard light sources on the market delivered the same results when connected to the endoscopes [5]. This allows the conclusion that some bottleneck effects among the components of the endoscope systems must be at the origin of such lower efficiency.

Modeling the Endoscope System

In LightTools (Synopsys©) the optomechanical model of one of the endoscope systems previously measured was built and the spectral properties and angular light distribution of the LED light source were implemented. Fiber bundles in rigid endoscopes are typically glued. Adhesive fills intermediate gaps between single fibers and fully absorbs incident rays. In this simulation model the fiber bundle is embedded into the adhesive, which is implemented as an absorbing layer (Figure 1). However, the production of fiber bundles is not an automated process and therefore every endoscope has a different alignment of single fibers. These manufacturing constraints

imply inaccuracies in the optical simulations because only defined alignment patterns (e.g. rectangular or hexagonal) can be simulated and they do not accurately correspond to the real alignment in a rigid endoscope.

The first goal was to investigate the absorption in the materials used by means of optical simulations. The analysis of the wavelength-dependent material losses shows that in the glass condensing cone bulk absorption and multiple reflections lead to marginal losses. Moreover, dispersive losses within the glass fibers of the fiber bundle were considered, which have a typical length of approximately 300 mm. If light is efficiently coupled into the glass fibers of the fiber bundle, the absorption losses in the fiber optics itself are negligible.

Therefore, the analysis focused on two critical optical interfaces that can cause high efficiency losses in rigid endoscopes:

- Light coupling between fiber optic cable of the external light source and glass condensing cone
- Light coupling between glass condensing cone and fiber bundle

We found out that most light losses occur at the second critical interface between the glass condensing cone and fiber bundle.

Étendue Efficiency Constraint

The reasons for the high losses at this critical interface are the constraints given by the Étendue: limitations of the glass condensing cone to focus light on the target surface $A_{\text{Fiberbundle}}$ and in a solid angle within the angle of acceptance of the glass fibers Ω_p . (Figure 4)

Figure 4 shows the Étendue efficiency calculation for the source, optical systems and image plane characteristic of the endoscope system described in Figure 1. The area of the source times the projected solid angle of the emission defines the limit of the Étendue

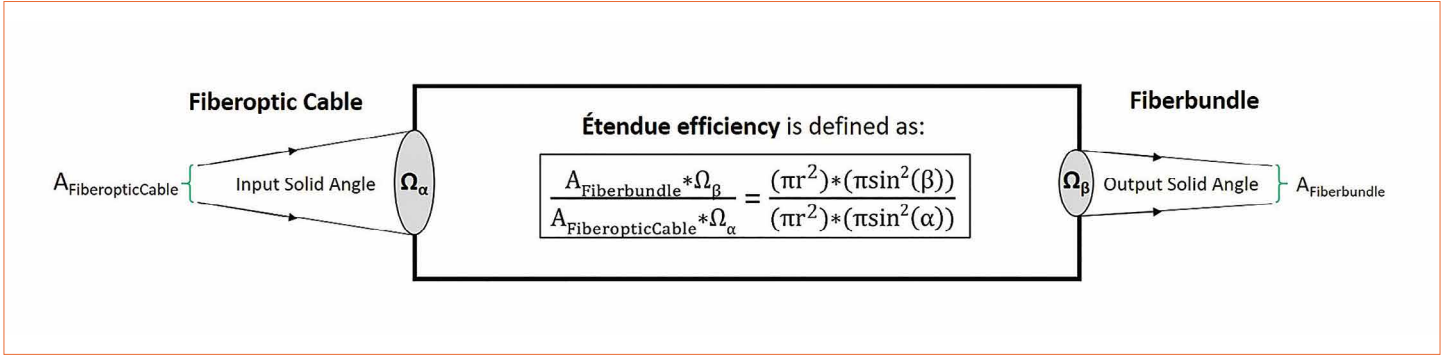

($A_{FiberopticCable} * \Omega_{\alpha}$). If the product of the aperture area of the collection optics and the projected solid angle of the output distribution ($A_{Fiberbundle} * \Omega_{\beta}$) is less than this limit, there will be an efficiency loss quantified by their ratio [6]. In most endoscope systems $A_{Fiberbundle}$ is significantly smaller than $A_{FiberopticCable}$, while α and β are comparable, resulting in an Étendue efficiency significantly smaller than 1. Moreover, because of adhesive absorption in the intermediate regions among the single glass fibers of $A_{Fiberbundle}$, final efficiency will be even lower.

Optical Development

Taking into account the constraints given by Étendue optical alternatives to the glass-condensing cone were

designed to maximize the system's theoretical degree of efficiency. In fact, the glass-condensing cone focuses light on a surface much bigger than the target surface $A_{Fiberbundle}$. Moreover, a significant fraction of the light that reaches the fiber bundle has an angular aperture greater than Ω_{β} .

Some examples are shown in Figure 5. On the left side, concentrator 1 illustrates a Compound Parabolic Concentrator (CPC) developed using the standard LightTools CPC-Utility for a light source whose surface area and entrance and exit solid angle are known. On the right side, concentrator 2 demonstrates a CPC developed as a free geometry using the software's optimization

engine. In the optimization process surface area and entrance solid angle of the light source are kept constant while the optimization parameters target surface and exit solid angle are equally weighted in the merit function.

This optimized CPC model only obtained a marginal efficiency improvement, which, after absorption in the adhesive layer of the fiber bundle, resulted in 21%, against the 16%-19% measured values of the current endoscopes.

We also designed optical systems made up of lenses and of a combination of lenses and CPCs. However, the best result was achieved by using CPCs only.

Figure 4: Schematic view of Étendue efficiency calculation with the source on the left (Fiber optic), the optical system as a black box (glass cone) and the image on the right (Fiber bundle). Ω_{α} is the solid angle subtended at the source by the entrance aperture of the optical system, Ω_{β} is the solid angle subtended at the image by the exit aperture

Figure 5: Development of two concentrators to focus the light of the LED external light source on the target surface $A_{Fiberbundle}$ and inside the solid angle Ω_{β} . The wireframe view shows the problems of back reflections

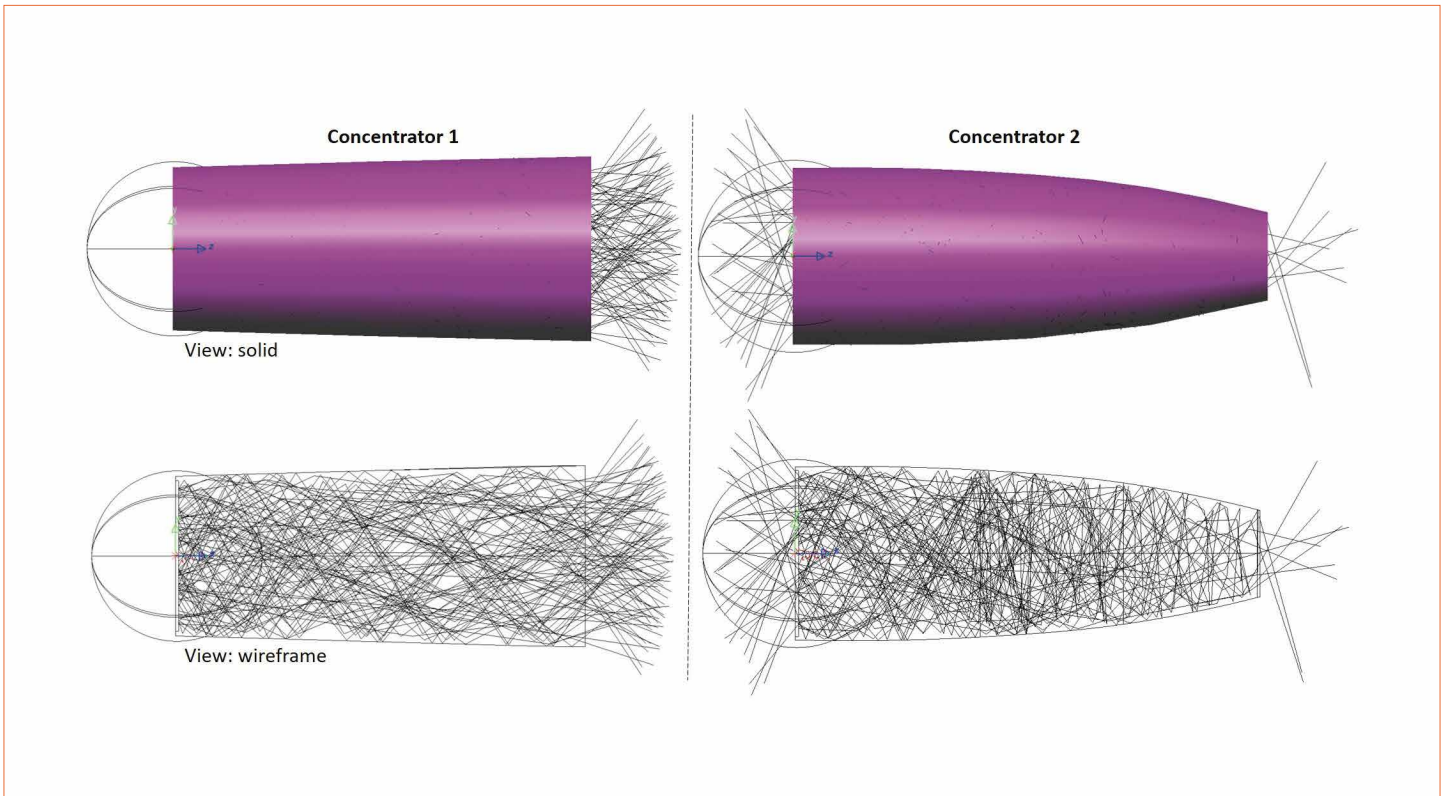

Conclusion

The typical geometrical configuration of light sources and fiber bundles in rigid endoscope systems is the reason for the low degree of efficiency (only 16%-19%) of the illumination optics of state-of-the-art endoscopes on the market. In fact, both the target surface and the exit solid angle are very small compared to the source area and emission solid angle, which is the reason for the low Étendue efficiency.

Aware of this limitation, we optimized the optical design of the central collimation unit in a rigid endoscope and obtained a slight improvement of the efficiency by means of a CPC-system. It is clear that the improvement potential is limited by the Étendue efficiency constraint and therefore this approach turned out to be not worthy of following.

A more efficient illumination optics can only be achieved by radically changing both the geometries

and the mechanisms that allow light collimation, transport and outcoupling inside the endoscope. Therefore, the future work will focus on these alternative approaches to avoid Étendue limitations. ■

Acknowledgements:

The authors thank the German Federal Ministry of Research and Education (BMBF) for its financial support of the project EDISON (Endoscopy Illumination System Optimization). EDISON is one of the ten projects in the research frame work initiative CoHMed (Connected Health in Medical Mountains) aimed at transferring current scientific trends in medical technology to biologize, miniaturize, and digitalize medical devices with industrial partners of the University of Furtwangen

References:

- [1] Shrestha R, Mohammed SK, Hasan MM, Zhang X, Wahid KA. Automated Adaptive Brightness in Wireless Capsule Endoscopy Using Image Segmentation and Sigmoid Function. IEEE transactions on biomedical circuits and systems 2016; 10: 884-892.
- [2] Norm DIN EN 60601-1:2006, Medizinisch elektrische Geräte - Teil 1: Allgemeine Festlegungen für die Sicherheit einschließlich der wesentlichen Leistungsmerkmale-Deutsche Fassung EN 60601-1:2006; Januar 2007
- [3] KARL STORZ; Highlights 2016 - Telepräsenz Bildgebende Systeme, Dokumentation, Beleuchtung, Gerätewagen: „Innovative Visualisierungsmodi in 2D und 3D“; 2016.
- [4] DIN EN 13032-4. Light and Lighting - Measurements and presentation of photometric data of lamps and luminaires - Part 4: LED lamps, modules and luminaires; German version EN 13032-4:2015.
- [5] Alexander Gaertner and Paola Belloni (2018): Analysis and Simulation of the Illumination Optics of Rigid Medical Endoscopes. In: Current Directions in Biomedical Engineering. To be published in September 2018.
- [6] Mark E. Kaminski, "LED illumination design in volume constraint environments", Proc. SPIE 5942, Nonimaging Optics and Efficient Illumination Systems II, 59420F (20 August 2005)

Widest selection of lighting components

In Stock



**MOUSER
ELECTRONICS.**

[mouser.com/Optoelectronics](https://www.mouser.com/Optoelectronics)

ORDER WITH CONFIDENCE

Authorised Distributor of semiconductors and electronic components

Rethinking the Photometric Data File Format

With increasing computing power, engineering disciplines cannot be imagined without simulations anymore. In lighting, photometric data and electronic processing of this data has become one of the most important tools for luminaire design and lighting design. This data is today provided in IES LM-63 format, a format that meanwhile has come to its limits. P. Eng. (Ret) Ian Ashdown, Senior Scientist at SunTracker Technologies Ltd., explains why the time for a change to a new standard has come and discusses the newly proposed standard and its properties in detail: ANSI/IES TM-33 respectively UNI 1603054.

It has been over 30 years since the first version of the IES LM-63-86, IES Recommended Standard File Format for Electronic Transfer of Photometric Data was published. After three revisions which mainly concerned the file format specification, IES LM-63 still focuses on “old technologies” and does not consider new requirements.

As professional lighting designers, we now have to consider color-changing luminaires, theatrical lighting, human-centric lighting, horticultural lighting, ultraviolet sterilization units, radiant heating devices, and more. We need to consider spectral power distributions, S/P ratios, melanopic and mesopic lumens, radiant and photon intensity distributions, photosynthetically active radiation (PAR), irradiance and photon flux density distributions, color rendition metrics ... the list goes on and on (Remark: Photon flux, also commonly referred to as quantum flux, is the rate of flow of photons. Radiant flux, by comparison, is the rate of flow of energy. The energy of a

photon is inversely proportional to its wavelength, so quantum flux is not directly comparable to radiant flux).

The LM-63 and EULUMDAT file formats are clearly incapable of characterizing luminaires for these applications. It is therefore time, indeed well past time, to rethink the photometric data file format. It is more than just photometric data, however; it is luminaire optical data that we need to think about.

Brief History of IES LM-63

If you perform lighting design calculations today, you can thank the efforts of the Illuminating Engineering Society's Computer Committee (IESCC) some thirty years ago. Its members recognized an industry need, and so developed and published IES LM-63-86, IES Recommended Standard File Format for Electronic Transfer of Photometric Data. With the growing popularity of the IBM Personal Computer for business applications, it was an idea whose time had come.

The need was clear: Lighting Technologies (Boulder, CO) had released its Lumen Micro lighting design and analysis software product in 1982, and luminaire manufacturers needed to provide photometric data for their products. For them, IES LM-63 was a god-send in that it established an industry-standard file format.

In keeping with the technology of the time, the file format was human-readable ASCII text, something that could be printed with a dot-matrix printer. It also resulted in files of only a few kilobytes, a definite advantage when data files were transferred by mail on 5-1/4 inch floppy diskettes capable of holding 360 kilobytes of data.



Figure 1: IBM Hollerith 80-character punch cards (Credits: Wikimedia Commons [1])

The file format itself revealed something of its origins by limiting line lengths to 80 characters - the width of an IBM Hollerith punch card in the 1960s (Figure 1).

Three decades later, our personal computers are one thousand times faster, with one million times the memory capacity and ten million times more data storage capacity. Data is transferred by fiber optic cable and satellite links at gigahertz rates ... and we are still using IES LM-63 photometric data files!

The “we” of course refers mostly to North America. In Europe, the equivalent file format is EULUMDAT, which was introduced in 1990 for use with Microsoft’s MS-DOS 3.0 operating system. Again, in keeping with the technology of the time, it was also human-readable ASCII text.



Figure 2: “Modern communications technology” - circa 1986 (Credits: Wikimedia Commons [2])

It is a testament to something - exactly what is unclear - that these two file formats have met the lighting industry’s needs for so long. Coming from an era of floppy diskettes and dial-up modems with acoustic couplers (Figure 2), they should have become extinct decades ago (The Chartered

Institute of Building Services Engineers in the United Kingdom introduced its CIBSE TM14 file format specification in 1988, but it has since slipped into obscurity).

To be fair, LM-63 was revised in 1991, 1995, and 2002. These revisions, however, at best tweaked

the file format specification to resolve various ambiguities and add a few minor features. What we have today is basically what was published in 1986, a time when the pinnacle of lamp technology was the compact fluorescent lamp with an electronic ballast.

If the LM-63 file format has an advantage, it is that it is an ANSI/IES standard that is maintained by an internationally-recognized standards organization. EULUMDAT, on the other hand, is a de facto standard that has been essentially frozen in time since its publication in 1990. Without the authority of a standards organization such as ANSI/IES or CEN (European Committee for Standardization) to maintain the file format, it can never be revised.

Today, the problem is that while LM-63 and EULUMDAT are still useful in terms of characterizing architectural and roadway luminaires, the lighting industry has moved beyond luminous intensity distributions.

An International Standard

Beginning in September 2016, the IESCC initiated a standards development project for the representation of luminaire optical data. Given today's global trade networks, it was imperative that the standard be international in scope rather than regional or national. Some fifty lighting industry companies and professionals from around the world were therefore recruited to contribute to the project.

Two years later, the effort has succeeded beyond all expectations. The IESCC worked closely with the Italian national standards organization (UNI) Technical Commission CT023, Light and Lighting, to produce two functionally equivalent versions of the standard: ANSI/IES TM-33, Standard Format for the Electronic Transfer of Luminaire Optical Data, and UNI 1603054, Light and Lighting - Specifications for a Format of

Photometric and Spectrometric Data Exchange of Lighting Equipment and of the Lamps. As of this writing, the CIE is considering adopting the standard as a joint CIE/ISO publication. In the meantime, CIE Division 1 is establishing a new technical committee to maintain what has become, as intended, an international standard.

For the sake of brevity, the standard will be referred in this article as "TM-33." However, all information and comments apply equally to UNI 1603054.

BIM Standards

Some North American readers may remember IESNA LM-74-05, Standard File Format for the Electronic Transfer of Luminaire Component Data. The IESCC worked on the development of this document for over a decade prior to its publication in 2005. It was an ambitious effort to combine all aspects of luminaires into a single data file, including far-field photometry, lamp and ballast information, physical geometry, construction materials and finishes, CAD drawings, photographs, and more.

Unfortunately, it was too ambitious. Despite the first release being focused on lamp data, the standard was never adopted by its intended audience of luminaire manufacturers, architects and engineers, lighting product specifiers, photometric testing laboratories, and lighting software developers. Simply put, the lighting industry at the time did not have a need for such a standard.

Today, we might look upon LM-74-05 as being an early example of a specialized building information management (BIM) schema, one that focused on a small subset of typically much larger datasets. (A document schema is conceptually equivalent to a file format specification.) The Green Building XML Schema (gbXML)

for BIM applications provides an excellent example.

Quoting from the gbXML Web site:

"The Green Building XML schema, or "gbXML," was developed to facilitate the transfer of building information stored in CAD-based building information models, enabling interoperability between disparate building design and engineering analysis software tools. This is all in the name of helping architects, engineers, and energy modelers to design more energy efficient buildings."

Unfortunately for the lighting industry, the gbXML schema has an XML "element" called "Photometry".

The description of the XML "Photometry" element reads:

"This element has been left open for use with other photometry definitions. Photometric data is required for various forms of lighting analysis. This tag provides a way for the photometric data to be passed. Since this can be done in a variety of ways (iesna LM-63, cibse TM14, EULUMDAT, etc.) a specific format is not being specified."

Defining a new luminaire optical data format that is compatible with the gbXML and similar BIM schemas therefore serves a clear and present need.

Understanding XML

The advantage of gbXML is that it is based on the international data exchange standard XML (eXtensible Markup Language). The details of this standard are complex and exhausting, but basically every XML document consists of text strings called "elements".

XML element example:

```
<name>Alfred E. Neuman</name>
```

... where the data is surrounded by begin and end "tags."

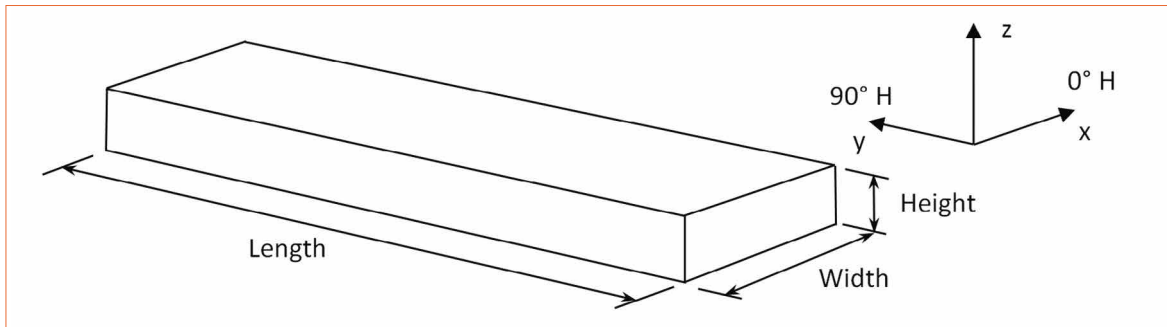

Figure 3:
Luminaire dimensions

These elements can be arranged in a hierarchy, such as:

```
<person>
  <name>Alfred E. Neuman
</name>
  <employer>MAD Magazine
</employer>
</person>
```

In this example, the `<person>` element is the “parent,” and any elements within it are its “children.”

Building on this simplest of representations, virtually any type of data can be unambiguously represented within an XML document. If a person or computer program reading an XML document encounters an unknown element tag, the element and its children (if any) can simply be ignored.

This, of course, is the problem with including LM-63 or EULUMDAT text files verbatim (i.e., as a multiline text string) within gbXML or similar BIM documents. Yes, it can be done, but the computer program reading the document needs to be able to somehow identify and read these files. Designing TM-33 as an XML document has resolved this problem.

Document Structure

Compared to the simplicity of photometric data files, the TM-33 document schema is relatively complex, with over 240 defined XML elements. However, the majority of these elements are optional. Existing IES LM-63 and EULUMDAT photometric data files can be ported to equivalent TM-33 documents with no loss of information, and with the resultant TM-33 files being not much larger than the original files.

With this, TM-33 documents are comprised of four sections: Header, Luminaire, Equipment, and Emitter.

Four sections of an TM-33 document in detail

Header

The header section includes information that is currently available in LM-63 and EULUMDAT files, such as manufacturer, catalog number, description, and test laboratory, but there are some interesting additions.

Interesting additions of TM-33 documents:

- GTIN
- Unique Identifier
- Reference
- More Information URI

The optional GTIN (Global Trade Item Number) element is an internationally-recognized identification code for trade items. Consumers encounter various forms of GTINs almost every day when they purchase products with barcode labels. A GTIN uniquely identifies the luminaire.

One of the problems with current photometric data files is that there is no version control. If a company reissues photometric data for a product, there is no way of distinguishing between files other than their file creation dates. If the files are copied for any reason, these dates can change. To address this issue, the optional Unique Identifier element identifies the TM-33 document with a Universally Unique Identifier (UUID). While a UUID does not prevent someone

from intentionally modifying the document data, it at least solves the problem of multiple files with the same name. Even better, UUIDs (which are commonly used to identify information in computer systems) are for all practical purposes unique, and do not require a central registration authority.

With the introduction of IoT technology, it is becoming increasingly important to keep track of related documents, particularly manuals, for luminaires. There may therefore be one or more optional Reference elements to list the names of these documents. For more volatile information, the optional More Information URI element provides a Uniform Resource Identifier (i.e., a Web address) for further luminaire information.

Luminaire

TM-33 represents the luminaire as an axis-aligned rectangular box or cylinder (FIG. 3) that bounds the actual luminaire geometry. The luminaire section therefore lists the dimensions of this “bounding box” as length, width, and height.

It could be argued that more detailed geometric information would be useful, such as ceiling cutout dimensions for recessed luminaires. This, however, is more properly addressed with BIM documents - TM-33 is concerned only with luminaire optical data.

Equipment

The equipment section describes the laboratory instruments used to perform the luminaire optical data measurements.

Lab instruments can include:

- Goniometer (intensity measurements)
- Integrating sphere (flux measurements)
- Spectroradiometer (spectral power distribution measurements)

and detailed information specific to these instruments, such as the goniometer type and spectroradiometer characteristics.

The term “goniometer” is something of a compromise in that the instruments may be designed to measure luminous intensity (i.e. a goniophotometer), radiant intensity (i.e. a goniometer), or photon intensity for horticultural applications (for which there is no accepted instrument name). The only difference between the three types is that the photosensor has different spectral weightings for each one (e.g. $V(\lambda)$ for luminous intensity).

Emitter

Photometric data files assume that the luminaire includes one or more removable lamps, but this concept does not apply to solid state lighting, which may have removable LED modules or non-removable LED arrays. Moreover, the lamps or LED modules may emit ultraviolet or infrared radiation rather than visible light. For the purposes of TM-33, these are therefore collectively referred to as “emitters.”

Additions to the Usual LM-63 and EULUMDAT Lamp Information

In addition to the usual LM-63 and EULUMDAT lamp information - quantity, rated lumens, input wattage and so forth -

the emitter information may optionally include power factor, correlated color temperature (CCT) values, color rendering metric values (Ra and R9 for CIE Colour Rendering, and Rf and Rg for IES TM-30-15 Color Rendition), and scotopic-to-photopic lumens (S/P) ratios. For variable-CCT luminaires, some of these values may need to be expressed as ranges.

One optional but important item is the “Data Generation” element. With photometric data files, it is impossible to know whether the luminous intensity data was measured in a laboratory or the result of a computer simulation. The Data Generation element distinguishes between the two, including whether the measured intensity data has been scaled based on the number of lamps and whether the measurement angles were interpolated. It also provides detailed information on the laboratory accreditation and instrument measurement uncertainties.

Spectroradiometric data

A key ability of the emitter section is to represent the spectral power distribution (SPD) of the emitter. Following IES TM-27-14, IES Standard Format for the Electronic Transfer of Spectral Data, the measured spectral radiant flux is reported for each wavelength.

Most SPDs are reported with constant wavelength intervals (e.g. 5 nm), but TM-33 does not impose such a restriction. Consequently, both continuous and line emission spectral features can be represented with arbitrary wavelength precision.

Intensity data

With photometric data files, most of the data represents the luminous intensity measurements for vertical and horizontal angles. The same is true for TM-33 documents in the emitter section except that, depending on the application, the intensity measurements may be based on luminous flux, radiant flux, photon flux, or spectral radiant flux.

Both radiant and photon intensity are measured over a specified range of wavelengths. When photon intensity is measured over the range of 400 nm to 700 nm, it is equivalent to photosynthetically active radiation (PAR).

Spectral radiant intensity distributions assign an SPD to each measurement. The distributions are useful for representing the variation in color with varying view angle, such as occurs with phosphor-coated white light LEDs.

Each intensity measurement is expressed as (for example):

```
<IntensityData horz="90.0"
vert="65.0">109
</IntensityData>
```

By explicitly expressing the vertical and horizontal angles for each measurement, there is no requirement for the data to be organized as a two-dimensional array of vertical angles and horizontal planes. This is important because some robotic goniometers are capable of measuring angular positions on a geodesic sphere and other complex angular patterns.

Table 1: Intensity measurement data, type and application

Intensity	Metric	Typical Applications
Luminous	lumens per steradian (candela)	Architectural and roadway lighting
Radiant	watts per steradian	UV sterilization and radiant heating
Photon	micromoles per steradian per second	Horticultural lighting
Spectral	watts per steradian per nanometer	Angular color uniformity

Application-Distance Radiometry

Application-distance photometry, also known as “near-field photometry,” was developed in the 1990s to represent the illuminance distribution on a ceiling above an indirect linear fluorescent luminaire. The laboratory measurement process was documented in IES LM-70-00, Guide to Near-Field Photometry, but it was never adopted by the lighting industry.

Today, however, there is an obvious application: linear LED strips used in vertical farms, where trays of leafy green vegetables are grown within half a meter of the luminaires. As of this writing, the IES and the American Society of Agricultural and Biological Engineers (ASABE) are collaborating on the development of a standard for application-distance radiometry measurements. The standard will also be applicable to ultraviolet sterilization units and infrared ovens.

TM-33 fully supports application-distance measurements for illuminance, irradiance, photon flux density, and spectral irradiance, with multiple planes oriented at any angle as required.

Channels

A luminaire may have multiple emitters with different SPDs, such as a theatrical luminaire with red, green, blue, and amber LEDs. If the intensity of each emitter can be independently dimmed without significantly changing the spatial intensity distribution, a “channel multiplier” can be applied to the channel intensity distribution to represent the luminaire intensity distribution when the channel is fully enabled to produce “white” light with the specified CCT. (The sum of the channel multipliers must be equal to unity.)

Emission Areas

Discomfort glare metrics such as the CIE Unified Glare Rating (CIE 117-1996) require knowledge of the luminous areas of luminaires as seen by the observer. TM-33 supports the representation of one or more rectangular or elliptical “emission areas” on any side of the luminaire bounding box or cylinder.

Emitter center

The “Emitter Center” element specifies the horizontal and vertical offsets of the presumed point source from the geometric center of the luminaire bounding box or cylinder.

Regulatory values

Measurement values presented in a TM-33 document can be one of three types: measured; rated; or nominal. A “rated” value is the value of a quantity used for specification purposes, established for a specified set of operating conditions of the product, while a “nominal value” is an approximate quantity value used to designate or identify the product. If a particular regulatory element (e., “Input Watts”) is absent, its values are assumed to have been measured or calculated from measured data.

Custom data

The “Custom Data” element provides a means of including custom data. For example, a company or government agency may require additional data that cannot be represented within the base TM-33 document. Multiple custom data elements are allowed, each one including a name element (e.g., “Italian CAM”), a UUID element to uniquely identify the parent “Custom Data” element, and an arbitrary sequence of XML elements to represent the custom data itself. Unless the software

reading the TM-33 document explicitly recognizes the custom data element, the element and all of its children elements will be ignored.

Summary

If the above description of the TM-33 document schema seems rather complex, that is because it is. While both the IES LM-63 and EULUMDAT file formats are specified using one to several pages, the ANSI/IES TM-33 and UNI 1603054 document specifications run to 70 pages or more.

Most of the XML elements comprising a TM-33 document, however, are optional. Porting an LM-33 or EULUMDAT data file to the TM-33 format results in documents that are not much larger than the original files, and with no loss of information. On the other hand, newly-generated TM-33 documents provide for a wealth of useful information for luminaires that can (and likely should) be included.

Finally, the TM-33 document schema was intentionally designed to be extensible. Whatever future additions may be made to the schema, they will always be completely backwards-compatible with the base document.

The lighting industry currently relies on photometric data file formats that were developed three decades ago. The TM-33 document schema has been designed for today and the future. ■

References:

- [1] Wikimedia Commons: https://commons.wikimedia.org/wiki/File:Card_puncher_-_NARA_-_513295.jpg
- [2] Wikimedia Commons: <https://upload.wikimedia.org/wikipedia/commons/thumb/e/e0/AcousticCouplerAK2000Tel.jpg/1024px-AcousticCouplerAK2000Tel.jpg>

Additive Optics Design and Fabrication for Smart Lighting Systems and Tailored Project Solutions

Since its initial invention back in 2009, printed optics has come a long way in the lighting industry. Additive optics fabrication is a future proof methodology of rapid prototyping custom LED optics by means of digital manufacturing technologies. Marco de Visser, Luximprint's Director of Marketing & Sales, breaks down the technology and explains how its features add value to the design and manufacture of smart lighting applications. From one of Luximprint's preferred optical design partners Physionary, Ramon van der Hilst, Founder and Business Development Manager, and Suresh Christopher, inventor of the state-of-the-art "target-to-source" optics design software, explain the benefits of an optimized design process.

Additive Optics Fabrication encompasses a 3D printing technology utilized to produce custom optics directly from a CAD file. In sharp contrast to conventional subtractive processes of milling, turning, grinding and polishing, additive manufacturing creates parts by building them up with progressive computer-controlled deposition of material, in a process that resembles printing, but with multiple passes until the desired 3D shape is achieved. How this works in detail and how optimized design software minimizes effort, while providing outstanding results is demonstrated.

The Process at a Glance: Droplets on Demand

Additive optics fabrication services use digital UV-jetting technologies whereby transparent droplets of a UV-curable acrylic are jetted onto a given surface and then cured by strong UV-lamps. The results of the process are geometrical or freeform shapes that may include transparent prisms or lenses, both individual lenses or lens arrays.

Like in digital printing, the platform keep going until the "optical resin" - basically a container with a liquid acrylic - is empty, and the "paper" - a translucent substrate material like PMMA, Polycarbonate and glass - needs to be replenished. Even though the material is deposited in discrete drops, the resulting surfaces are smooth straight from the printer and don't require post-processing.

Smooth and frosted finishes

In addition to the smooth surface finishes, a defined surface roughness can be selected, for example, to generate a targeted scattering of light (spectral BSDF). Rough surfaces can be applied onto the optical part as a whole, or selectively applied onto the lenses or their connected surfaces, in one single process.

From Overstock to Novel Lens Design

One interesting feature arising directly from the additive optics fabrication process is replacement of the sheet material by any given lens object. As such, any existing lens module can be "reworked" into a new design by just adding some novel lens features to it. Painful tooling errors, such as unexpected blinding or aberration effects, can be compensated and tested before excessive tooling re-investments or costly tooling iterations are done.

The lens modules to be used may include a diversity of bolder lens types such as TIR lenses or lens arrays, or generally flatter sheet materials such as prismatic and light guiding plates, among others.

Sheet materials - or individual lens objects - can be treated on both the top and bottom surface, as long as they are flat, using the dual sided printing methodology of the process.

This capability opens up an interesting space in the lighting market to tailor lighting system performance, take away unforeseen (glare) effects or customize the aesthetics in a way that was not available before. Apart from the time and cost savings that can be realized during the early development stages, the ecological and economic benefits of re-using obsolete stock or standard “off-the-shelf” lens materials are of significant meaning to the industry.

Technology Meets Application

When it comes to its relevance for the lighting industry, we can break down additive optics fabrication into some main product areas of interest.

Printed optics

Lighting fixtures typically incorporate one or more secondary or tertiary plastic optics. They may consist of lenses, total internal reflection (TIR) optics, and diffusers that concentrate the light, magnify its intensity, guide it to a given target surface, and then finally blur it to enhance beam and color uniformity.

Printed reflectors

Based on the smooth surfaces manufacturing capability, another interesting type of secondary optics can be produced: Reflective surfaces. Deposition of aluminum coatings or other types of reflective finishes onto the surface turns the smooth (high polish) or textured

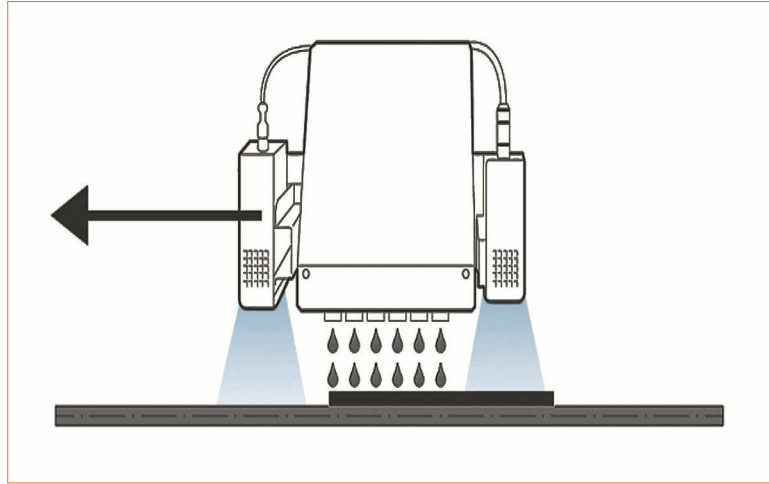

Figure 1: Building a lens. An accurate deposition of droplets onto an optical sheet material is required [1]

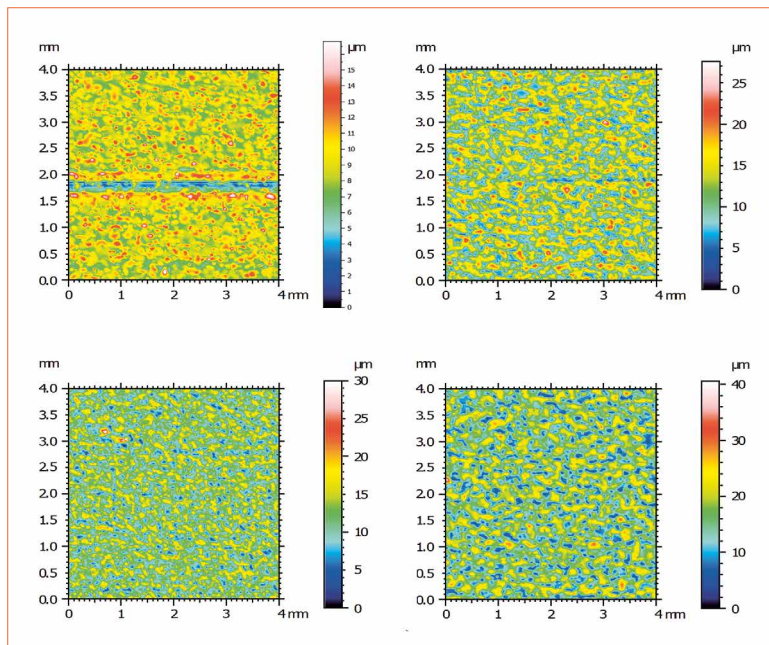

Figure 2: Surface roughness measurements (Ra / Rz in μm) of printed frosted finishes conforms international ISO 4287 standards. An 800 microns high pass filter was used

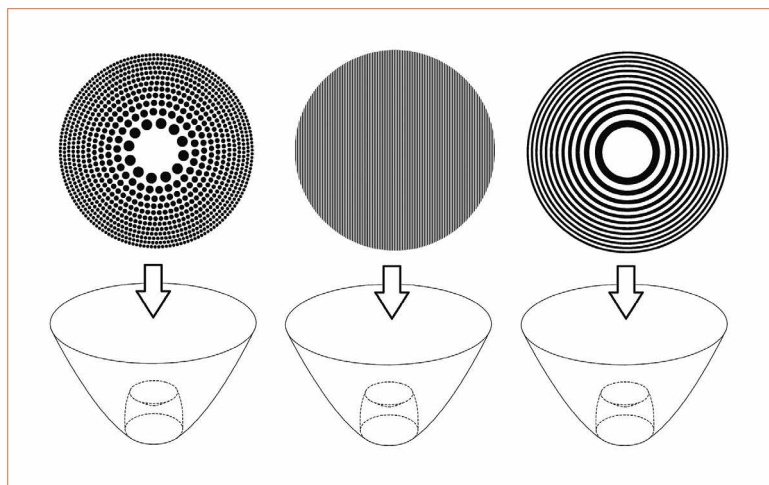

Figure 3: Existing lens bases, such as TIR lenses, can be upgraded with novel lens design features to optimize or adjust the lighting system performance

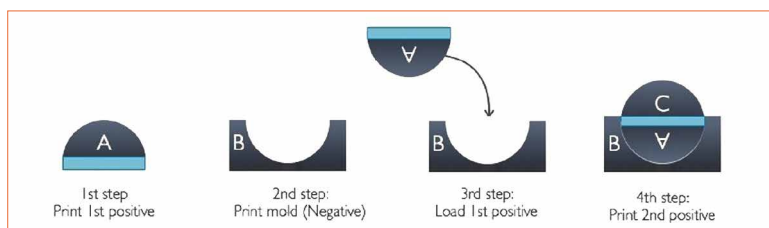

Figure 4: Explanation of dual sided lens with sheet printing methodology

Figure 5:
Printed gradient array
of micro lenses

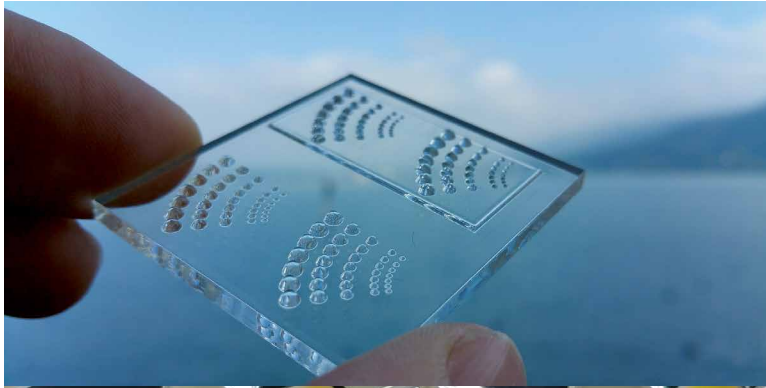

Figure 6:
Smoothness straight
from the printer is key
for reflective optical
quality surfaces

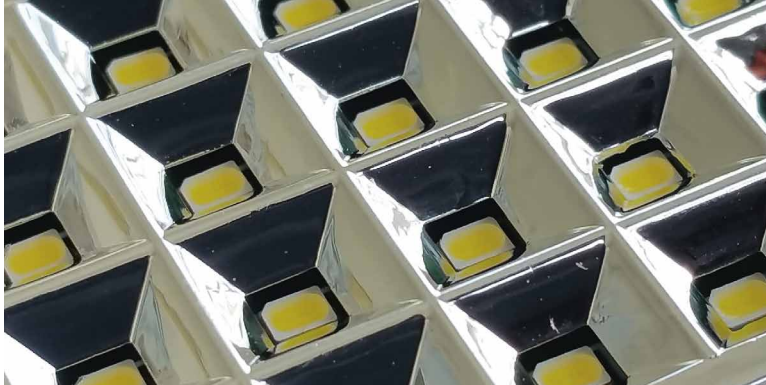

Figure 7:
Defined Frosted
Finishes for anti-
glare and enhanced
light control, nearing
common industry
standards for mold
roughness



Figure 8:
In addition to optical
quality parts, imprints
of part positives
enable rapid material
replacement for
other lighting system
components, such as
metals

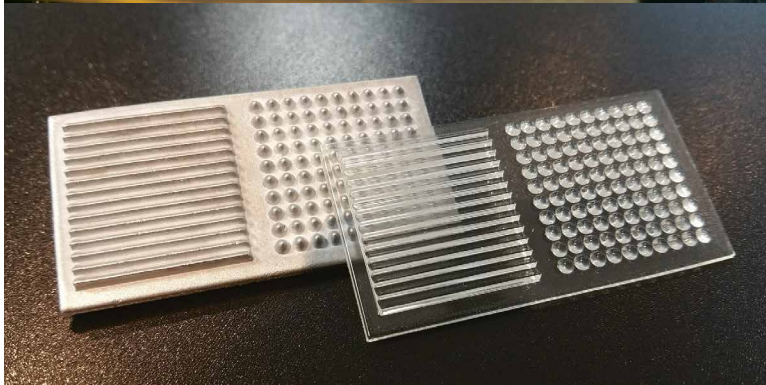
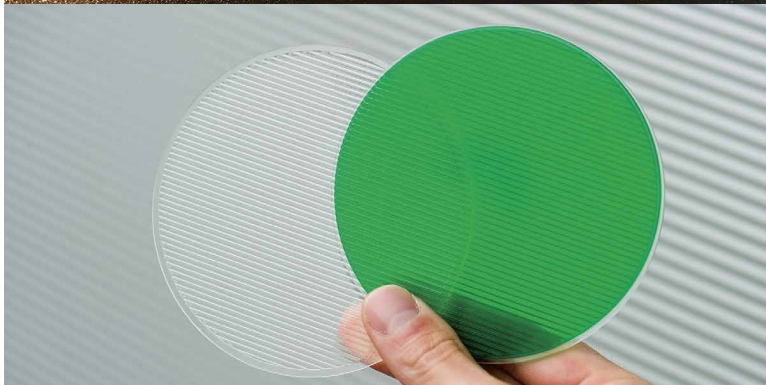

Figure 9:
Example of a green
color filter integrated
into one single prism
lens part



(matte) surfaces into a fully functional reflector item, from where functional testing of new systems can be done rapidly.

Printed diffusers

Printed diffusers aim for a uniform light distribution and a comfortable light appearance. They provide an undefined or defined scattering of light aiming for better light control, reflectivity, source hiding, efficiency and finally, aesthetics. Thanks to the accurate droplet placement, a high level of customization can be achieved.

Printed molds and tools

Elaborating on the smooth optical quality surfaces to another extreme ends up in rapid fabrication of mold tools. Printing the lens “negative” rather than the positive, enables users to take immediate benefit of the smoothness, also for other purposes than diffractive or reflective optics.

In addition, lens positives are used for making “imprints” into secondary materials, such as ceramics or clay specialties, enabling rapid creation of soft manufacturing tooling for other material types. From this perspective, it is easy to replace optical materials or even non-optical materials, and from cool / UV curing resins to hot melt materials.

Optographix

In addition to the optical lens parts for the engineering community, the additive printing approach gives the creative lighting design space access to the color features of the manufacturing process. A unique combination of “optics” and “graphics”, including either translucent “colored textures” or “color lenses”, in mono-color or multi-color, greatly enrich the ambiance of a given space or surface.

Fortunately, there are also some very interesting developments underway that enrich today’s optics

and system design landscape. Where additive optics fabrication technology breaks down the barriers of manufacture and addresses the “pain points” in today’s lens fabrication processes, conventional optics design software still needs a high level of expertise and time to get to a solution, mainly a compromise between the design software and the fabrication process.

The answer to overcoming the bottlenecks in conventional optics design methodologies is to apply modern mathematical methods from physics and computer programming to generate the required optics, leading the focus away from how to achieve it towards where the light is desired.

Complexity is for Free

Traditionally, the staple of optical design has been ray-tracing, combined with human expertise to optimize parameters of the design. This approach often entails manually finding the best optical design for a certain problem, relying on the expert’s insight to foresee the direction in which the optimal solution can be found. This reliance on expertise and foresight is not a coincidence! Rather, it is a consequence of the ray-tracing method utilized in most optics design programs.

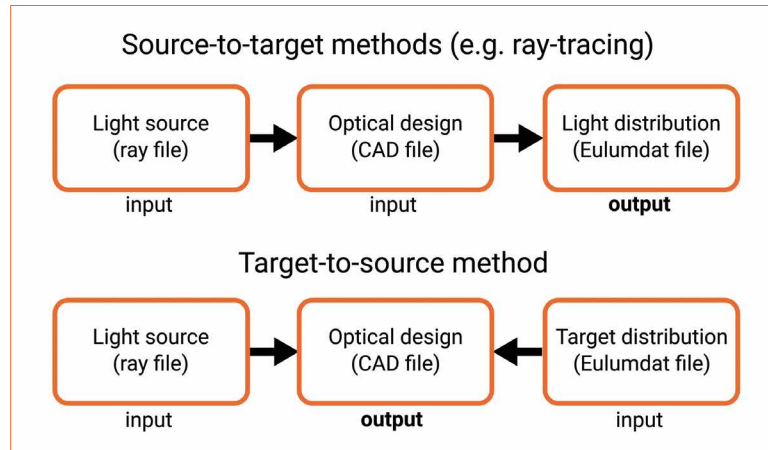

Figures 10 a&b: Diagram Ray-tracing method [Light source (ray file)] → [Secondary optics (CAD)] → [External distribution of light (Eulumdat)] (a). Target-to-source method [Light source (ray file)] → [Secondary optics (CAD)] ← [External distribution of light (Eulumdat)] (b)

While the ray-tracing method is very reliable, it works in a straightforward manner. It begins at the light source in order to arrive at the target: the external distribution of light often stored as a Eulumdat file or a ray-file. The optical design here is “input”, whereas the target distribution is “output”. An important consequence of this source-to-target method is that a complex target distribution requires the optical designer to input an optical design with similar complexity in order to control the light well. One can imagine that this becomes arduous if a large amount of complexity is required.

Applying the target-to-source method of calculating optical design, in this case, the output is the optical design in a digital format, whereas the inputs are the light source properties and the requested

external distribution of light. While there is a mathematically infinite set of optical solutions that provide the requested distribution given the light source, modern optimization algorithms can cut through the proverbial fog to provide the most practical designs. An important consequence of this method is that at least the same level of complexity is transferred from the requested distribution of light to the optical design.

Image faceted lens

The first application of this technology is through the programmatic generation of faceted lens designs. A faceted lens consists of many similar-sized facets that “cut up” the light from the source. Each facet then aims the narrow bundle of light passing through it in a specific direction,



Figure 11: With additive optics design and fabrication, complexity is “free”: designing and printing a complicated lens is no more difficult than a basic one - “Sunflower Fresnel”, a multi-facet lens precisely directing light to the illumination target

Figure 12:
Lens bundles from
facetted lens form
light typography

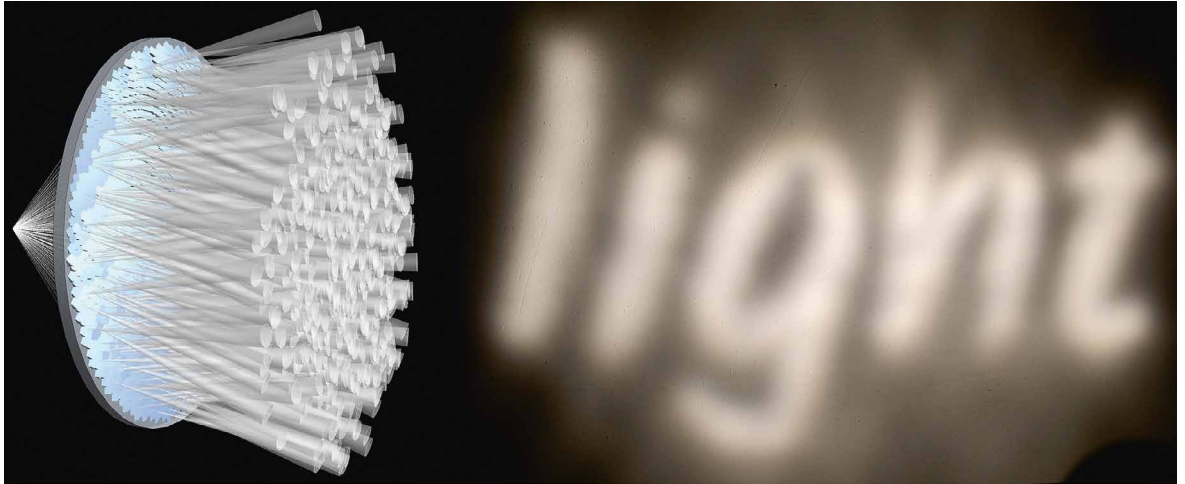

such that all the beams from all the facets together make the requested external distribution of light. It does not matter whether that goal is a simple spotlight, or two spotlights, or something as complex as a logo. The complexity of the optical design stays the same, and often a single optical element is enough.

Image bundles from a faceted lens

A lens of 50 mm diameter with 4 mm² facets has approximately 500 facets. If an LED with a light emitting surface length of 2.4 mm is placed 25 mm behind the lens, each of the 500 beams has a (FWHM) opening angle of 5-10°. This spread in opening angles can be used to optimize the distribution of light, or eliminated by changing the relative size of the facets. The beams could be made even narrower by using a smaller LED at a larger distance with a practical limit of about 2°, though placing the LED closer to the lens also reduces the size of the outer beams while at the same time increasing the size of the middle beams. The preferable method depends on the application.

One advantage of having a relatively large lens surface is that it is possible to reduce glare. Depending on the target distribution, facets on different areas of the lens can aim in

similar directions. For someone looking into the light, the LED's sharp point of light is now spread over multiple points in different areas of the lens. This has the added benefit that it reduces the sensitivity to fouling by environmental effects, and redundancy in the case of partial obstruction.

The target-to-source method is ideally suited to give the creativity back to the light architects, artists, and designers by providing reliable optical designs with proven quality, while being able to deliver unique designs for every assignment. Using additive manufacturing, every lighting project has access to optimized optical designs of the level of complexity needed.

Additive optics manufacturing combined with target-to-source optical design methods open up a world of opportunities for creative lighting designers in branches as diverse as public lighting, artistry, architectural lighting, art illumination, and advertising. Because the efficiency of single element optics is naturally high compared to most other methods of beam-shaping, e.g. image projection methods and shutters, it is our expectation that faceted lenses and other target-to-source based optical designs will become the norm for the creative lighting industry.

Optics Design Meets 3D Printing Technology

New opportunities in custom optics design and development arise for the lighting industry when "smart optics design" and "additive optics fabrication" get together. A combination of, for example, Luximprint and Physionary services, is extremely powerful, as the intelligent piece of design software incorporates and considers the optical 3D printing platform capabilities when generating designs for manufacture. Product developers, on the one hand, can now benefit from the 'printing-on-demand' of custom designed LED optics, with no costly commitments to tooling and inventory, while creative lighting specifiers can get uncompromised lighting solutions, meeting the exact quantities and needs for their custom project. All in just a matter of days. ■

References:

- [1] Luximprint - Additive Optics Fabrication Services for inspirational, decorative and functional optical plastics www.luximprint.com
- [2] Physionary - Revolutionary Target-Source Optics Design SW for custom Optics - www.physionary.nl

Natural & Healthy Light

SunLike
Powered by 

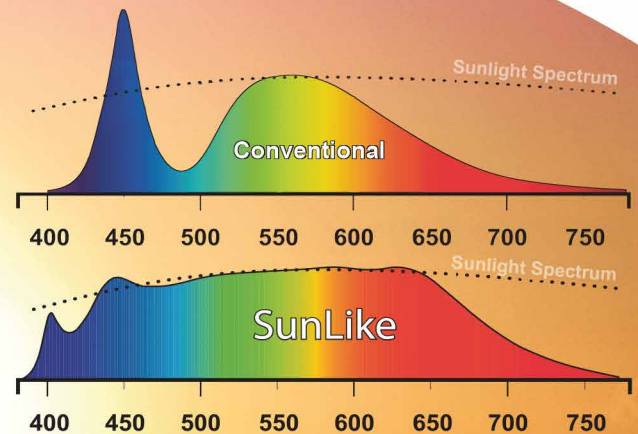

- Improves the light experience for human health benefits
- Closely matches the spectrum of natural sunlight
- Harmonizes light output with natural circadian rhythms
- Minimizes negative effects of conventional LED light sources



SEOUL SEMICONDUCTOR

Visit seoulsemicon.com to learn more about SunLike Series LEDs.
info.europe@seoulsemicon.com



Qualified Bluetooth Mesh – Making Lighting Controls Future-Proof

At Lightfair USA, Siegfried Luger met with Patrick Durand, Worldwide Technical Director at Future Lighting Solutions. One of Mr. Durand's striking statements was: "Basically, what we need is to future-proof lighting control." This was the first time that this important aspect was so clearly addressed by a representative of the industry. This led us to asking Mr. Durand to provide LED professional with a technical article to clarify the current situation, explain the technical background that led him to making that statement and to give an idea of which requirements a controls solution must fulfill to be truly future-proof.

Building infrastructure is usually designed to last for decades. This is no different for lighting equipment. When a building owner or building manager decides to invest in lighting control they need to have the confidence that their decision is going to be the right one not just for the next couple of years, but for the next decade, or more. But today the bombardment of all the new technologies that are being introduced causes a building manager to say, "I'll wait until the technology landscape matures where one technology wins." With a future-proof lighting control system, there would be no need to have that type of concern. The idea sounds simple, but we need to figure out how to achieve it.

The Basics of a Future-Proof Installation

As a first step, it is necessary to start with a basic installation: a switch, a sensor/controller and nothing more. There shouldn't be any gateways; no gateway for commissioning; no gateway for controlling. However, the system needs to be able to optionally add a gateway. The gateway, in this case, is just a protocol translator, nothing else. It is not like a ZigBee gateway/server for large installations where the ZigBee gateway manages the network and if the main gateway fails, there is potentially a single point of failure for the entire system. The future-proof lighting control gateway is simply a bridge from the wireless protocol to, say, a BACnet building management system, or KNX system, or Cloud-based system, or even a technology that's going to be invented several years from now.

A simple optional protocol translator gateway gives the user the choice of what to do, when to do it and how far to go. If, during the initial installation of a lighting control system, the building manager is not

ready for any complexity and just wants the switch and the controller, we need a wireless technology that supports these needs (Figure 1).

But, if two years later he/she says, "My building is upgrading and a BACnet building automation system is being installed," that should not pose any issues, whether the building automation system is from Schneider, Siemens, Johnson Control, Honeywell, or whomever. And the reason for the building manager's peace of mind is that there is no need to change anything from the initial installation of wireless luminaires and switches other than adding a limited number of protocol translator gateways to seamlessly translate and forward data from the wireless protocol to the BACnet protocol. If five years later, the building manager realizes that he/she can no longer achieve his/her objectives with BACnet and wants to go to a Cloud-based system, he/she can simply change the limited number of BACnet gateways to Cloud-based gateways, and that's it. You have a future-proof solution.

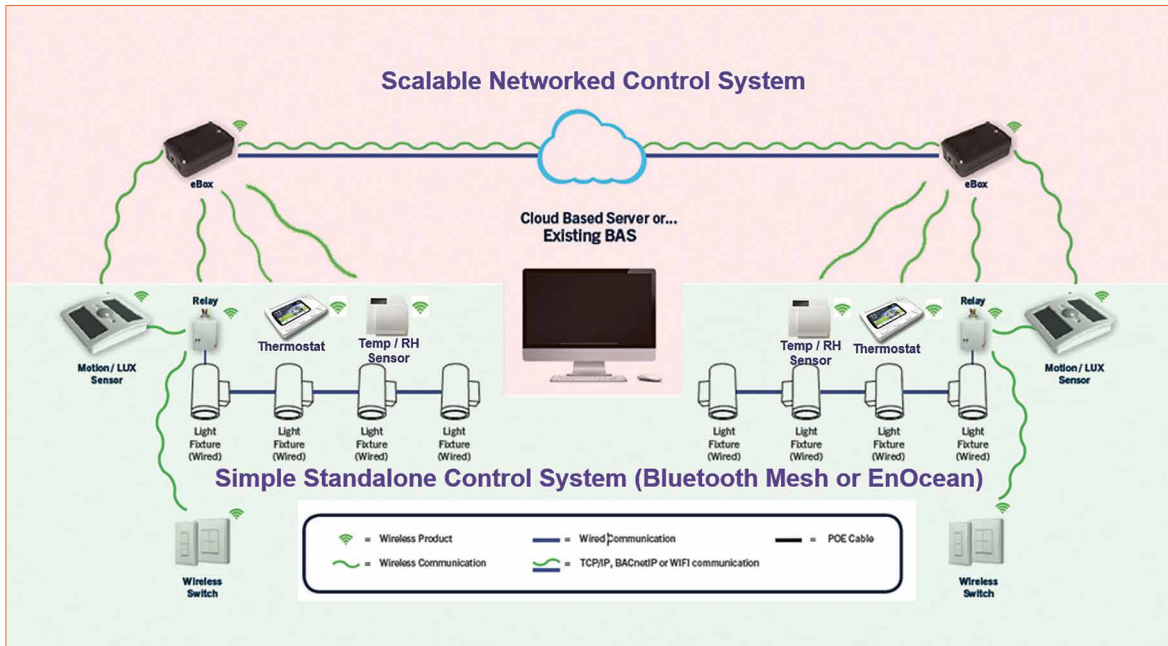

Figure 1: A future-proof lighting control architecture

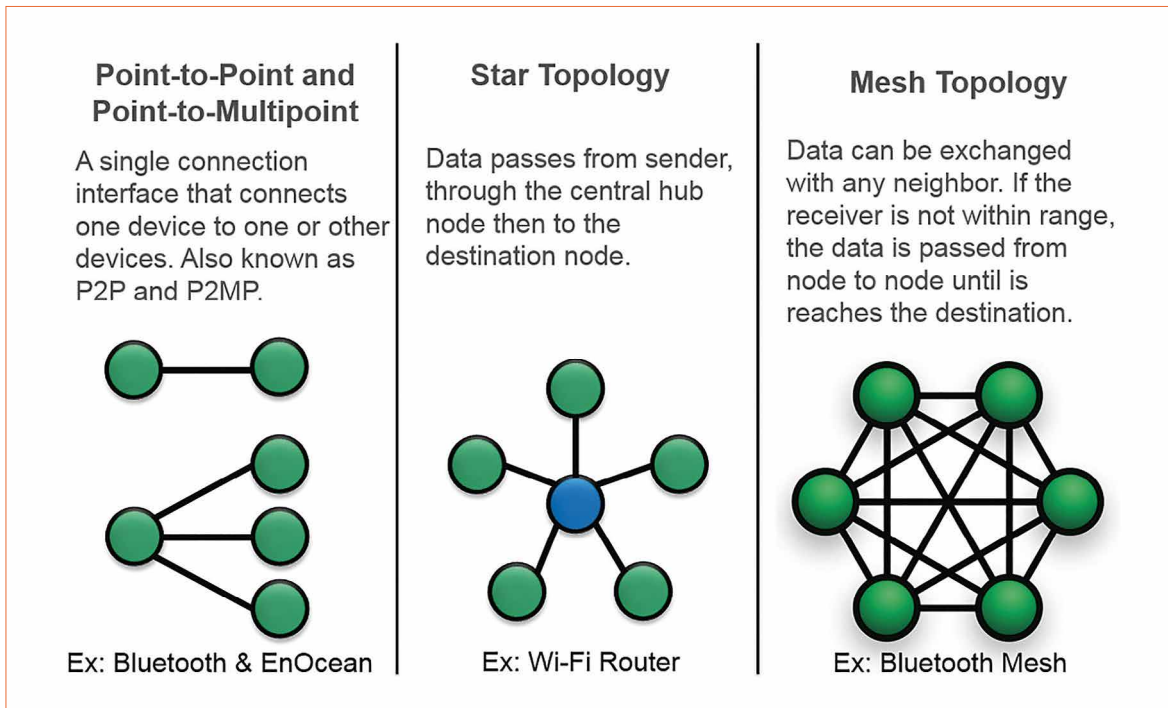

Figure 2: Network topologies for lighting control

Wireless Technologies for a Future-Proof Installation

The topology of a wireless system makes all the difference in being able to future-proof a lighting control installation. If it supports point-to-point and point to multi-point, this means that the switch or sensor communicates directly to the controller, which is the wireless device that provides the signal to the LED driver to turn it on/off or to dim it to a specified level. It's mainly EnOcean and Bluetooth that support this type of topology from an open standard standpoint (Figure 2).

With the new Qualified Bluetooth Mesh standard that was first released in July 2017, there is a mesh of nodes that can forward the data to other nodes in between the wireless switch/sensor to the wireless controller. Although the accurate name for the Bluetooth Mesh topology is many-to-many, one can still think of Bluetooth Mesh as supporting the point-to-point topology with the added benefit of being able to extend the range and reliability of the wireless network via meshing.

Technically, there are significant differences between Bluetooth Low Energy (LE) and Bluetooth Mesh standards, although they both leverage the same radio chip or radio module. It's the ability of Qualified Bluetooth Mesh to relay the data that truly sets the two standards apart. Furthermore, for Bluetooth LE, security is optional where for Bluetooth Mesh, security is mandatory where it's built into the standard where even the commissioning process itself is secure. From a similarity standpoint, the Bluetooth Mesh

standard actually incorporates the entire Bluetooth LE functionality, which allows existing mobile devices with Bluetooth LE to directly connect to and control a Bluetooth Mesh network. And since gateways are optional devices in a Bluetooth Mesh network that can simply act as a protocol translator between Bluetooth Mesh and a building automation system or a Cloud service, Bluetooth Mesh can truly enable future-proof lighting control systems.

While the decision between EnOcean and Bluetooth Mesh is finally a question of personal preference, both systems have advantages and drawbacks. EnOcean is already installed in over 400,000 buildings. It's a mature protocol. It's an accepted protocol, particularly in HVAC and in lighting control. Another advantage of EnOcean is that it operates in the sub-GHz frequency range where the wireless signal can travel through walls further and there's no risk of interference with any of the 2.4 GHz wireless systems in highly congested environments such as the center of New York City.

On the other hand, the benefit of Bluetooth over EnOcean is that it's supported on every mobile device to directly communicate with the Bluetooth Mesh controller, which greatly simplifies the commissioning process. The other major benefit of Bluetooth technology is that it supports over-the-air updates, which has a future-proofing advantage over EnOcean. Finally, there is the cost advantage of Bluetooth Mesh since there are multiple Bluetooth radio and module vendors where there is only a single formal vendor of the EnOcean radio and modules. At the end of the day, cost is the number one barrier to the mainstream adoption of wireless lighting control solutions (assuming that the control solution is simple, reliable, scalable and secure). What the lighting industry needs are control solutions that are so cost effective, that lighting OEMs integrate a wireless controller in the

luminaire regardless whether the end user (building manager) will immediately leverage the capabilities. With the scale and presence of Bluetooth, it's mesh derivative is the only technology that has a realistic chance to live up to both the low-cost and future-proofing requirements for lighting control solutions.

It's important to mention that at this time, Bluetooth Mesh is still a new standard that requires maturing and additional features before it can take the undisputed title of the dominant protocol for indoor commercial and industrial lighting control. This will still likely take a few more years to materialize but this is where the over-the-air updates functionality is such a critical capability. Furthermore, with Bluetooth 5, it's now possible to increase the range of the Bluetooth signal up to a theoretical 240m, which should address most if not all concerns about range for the technology in indoor environments.

But for what it can do today with available Qualified Bluetooth Mesh end products like controllers, sensors and switches, end customers can start installing the core part of the future-proof lighting control systems. In the first half of 2019, we are expecting the launch of the first optional gateways to manage multiple sites and have advanced functionality such as occupancy heatmapping, asset tracking, beaconing, power consumption monitoring and more.

The interoperability of Bluetooth systems

Incompatibility is one of the major obstacles for a quick and mainstream adoption of lighting control systems. Currently, there are several proprietary lighting control systems on the market where some even leverage Bluetooth as their wireless radio where they are implementing a mesh network. Since the Qualified Bluetooth Mesh standard was only released in July 2017, many of these lighting control companies, where most are

relatively small startups, had to develop their own proprietary technology. In many respects, some of these proprietary protocols are more advanced in functionality than the current version of the Qualified Bluetooth Mesh standard. As a result, the existing solutions that are leveraging a Bluetooth radio may wait until the Qualified Bluetooth Mesh standard matures before adopting it.

However, there is no doubt that Qualified Bluetooth Mesh will accelerate standardization and commoditization of wireless lighting control. The standard is written in a way that really promotes full interoperability, which is more than just at the user level. An example, in a retrofit project that includes luminaires from companies A (1000 lm downlights), B (2000 lm downlights), and C (4000 lm troffers): if they all include Qualified Bluetooth Mesh controllers, the contractor can install them like traditional luminaires and the building manager can easily commission and control them with the same mobile App or wireless wall-mount switch. Furthermore, the building owner will have the choice of leveraging different third party mobile Apps that will be flooding the market in the coming months and years. As a result, over time, there will be less differentiation at the hardware level where it will be the software functionality and user experience that will determine the adoption of a particular solution. With a fully interoperable standard, Qualified Bluetooth Mesh will drive down the cost and complexity of lighting control. The end goal is that the lighting OEM market will have sufficient choice of low cost and simple wireless control solutions where they will embed them into the luminaire as a standard offering regardless of whether the end customer takes immediate advantage of the added functionality or waits before enabling the wireless functionality. And as more Qualified Bluetooth Mesh solutions and luminaires are launched in the market, specifiers (Architects,

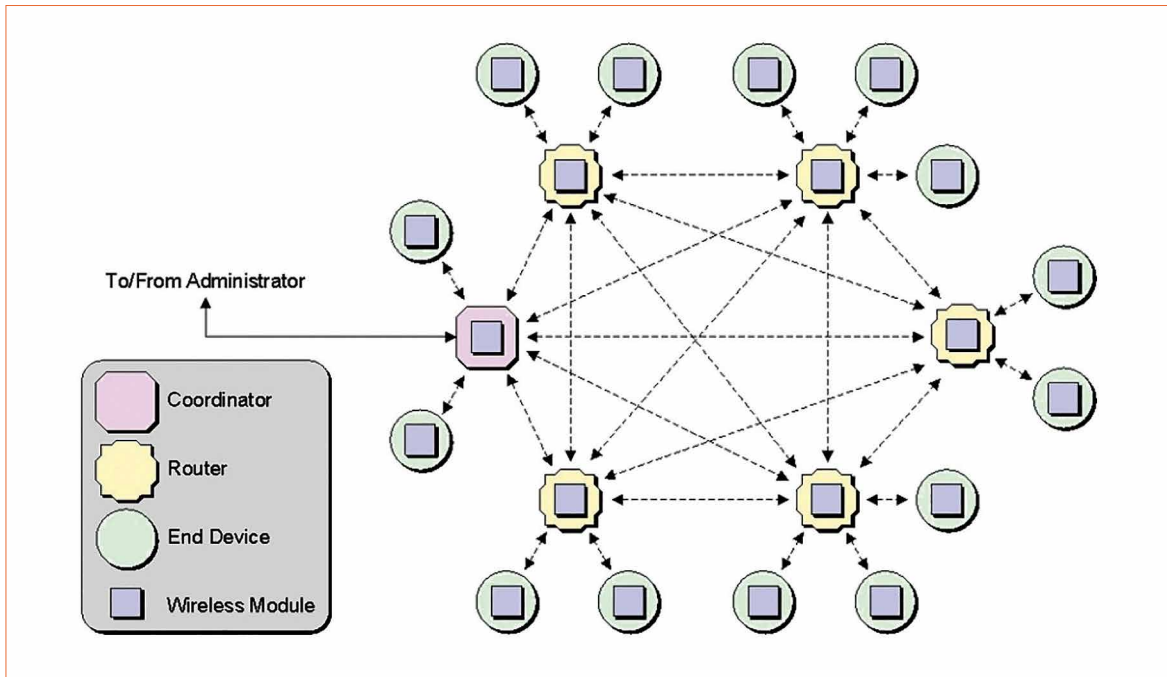

Figure 3:
Architecture of a
ZigBee Network
(source: Synapse
Wireless)

Designers, Engineers) will start specifying Qualified Bluetooth Mesh for new building and retrofit projects. Once this occurs, that's when the age of future-proof lighting control solutions will truly begin.

Security of Bluetooth Mesh solutions

Security is a mandatory part of the Bluetooth Mesh standard where all mesh messages are encrypted and authenticated. There are 3 types of security keys in Qualified Bluetooth Mesh. The first is the network key that is critical for a lighting node to join and send a message that will propagate through the mesh network. Furthermore, it's possible to create sub networks (or zones like a conference room zone or receptionist zone) where each sub network has its own network key to enable a user to only have authority to control lights in his/her office but not for other offices in the building. The second is an application key so that a user who only has access to control lights cannot have access to the HVAC or other building systems. The third is the device key, which is important for removing a node from the network where the network and application keys are refreshed for the remaining nodes. This way, a discarded node (luminaire in

the trashcan) cannot be used to attack the building network by a resourceful hacker.

Even with security, there are ways for lighting control vendors to go beyond the standard to differentiate themselves. For example, in an installation of luminaires from various luminaire vendors that are all leveraging Qualified Bluetooth Mesh, one approach is to automatically validate in the background of the commissioning process via the Cloud whether the node firmware contains any vulnerabilities or malware that can negatively impact the network before it is allowed to join it. No extra hardware devices would be required as the installer would leverage the same Internet connected mobile device for this enhanced commissioning process.

Is the multi-protocol approach valid?

Besides Bluetooth, Wi-Fi is also implemented in all mobile devices. And since Wi-Fi routers are found almost everywhere, it seems logical to leverage this infrastructure. The question is: is that really another direction we should consider or should we potentially consider a multi-protocol node to hedge our bets?

From a technical standpoint, it's possible to have a wireless node that can support multiple protocols as there are several radio chips that support both Bluetooth and Wi-Fi and other chips that support both Bluetooth and 802.15.4 (ZigBee). However, one must remember that the difficult part in lighting control is not the hardware but rather the firmware and software. To support multiple protocols will necessarily add a significant level of complexity and may render the node incompatible with nodes from other vendors. Just like when it was unclear whether Blu-ray or HD-DVD would win the disc format war, some equipment vendors released expensive video players that supported both formats. However, the HD video disc industry only started to blossom when Blu-ray was declared the winner.

It's important to understand the differences between Bluetooth vs. Wi-Fi and ZigBee and not attempt to employ a riskier multi-protocol node strategy at the luminaire level. Wi-Fi power consumption is higher than Bluetooth LE/Mesh and requires a router where we've all experienced router failures at home or in the office or at a hotel. For large scale ZigBee installations, gateways are required, which add a level of complexity and single points

Figure 4:
Qualified Bluetooth
Mesh products [1]

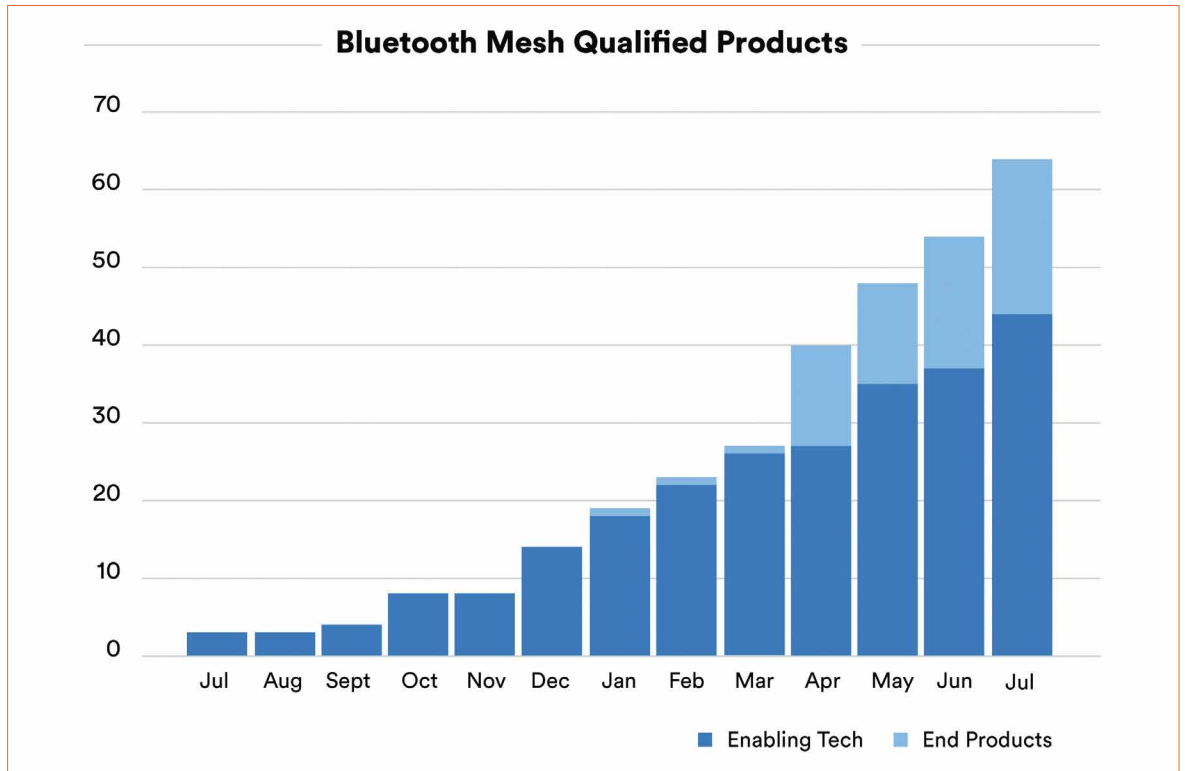

of failures since the gateways are managing the ZigBee network (Figure 3).

But at the end of the day, selecting the winning solution is about selecting a technology that has an advantage in cost, simplicity, reliability, scalability and security where Bluetooth Mesh is unmatched. With a year under its belt, the Bluetooth Mesh standard has already been implemented in 65 interoperable products from various vendors where that number is expected to grow exponentially over the next few years (Figure 4). The key right now is to build an ecosystem of Bluetooth Mesh solutions as quickly as possible.

About the Ecosystem of Solutions

A large ecosystem of solutions based on an open interoperable standard like Qualified Bluetooth Mesh is required to support any conceivable project specification from the type of signal from the controller to the LED driver (DALI, 0-10V, PWM), to different form-factors for integration into the luminaire, to supporting different

type of sensors (occupancy, daylight harvesting, CO₂, VOCs, noise, temperature, humidity) and functionality (people counting, asset tracking, beaconing, power metering, local vs. Cloud based system).

The benefit of the future-proofing characteristics of Qualified Bluetooth Mesh is that if the end customer is not ready to leverage the data on the Cloud that a system can generate, they don't need to include gateways at the time of installation of the lighting control system. But having the peace of mind that if a strategic decision is made at some point to leverage the power of the Cloud, the option to do so is available with low-cost Qualified Bluetooth Mesh gateways that are currently being designed by a number of vendors. As an example, for a retail store, understanding where customers are spending most of their time during the course of the day or the holiday season may encourage them to make changes that can increase revenue. Alternatively, understanding how many people are in a conference room may adjust the HVAC system to maximize comfort or save energy.

There have been several press releases about the potential emergence of Li-Fi for retail and museums where data can be sent directly to the phone by modulating the light in the luminaire to the light sensor on the phone where the user can receive location specific messages such as product information. The challenge with Li-Fi is that it requires specialized equipment and is expensive and complex to implement. Furthermore, the Bluetooth standard already inherently supports beaconing, which provides the same functionality without the need for extra equipment at the luminaire level. Again, Bluetooth Mesh responds to the evolving needs of the market in a simple low-cost way.

Measures to push the ecosystem of solutions

There are two types of lighting OEMs in terms of lighting control. The first type is reacting to the project specification and simply including the specified control product in the luminaire without learning its features/benefits nor how to commission it. There is no commitment or investment from the lighting OEM in this case.

The second type are lighting OEMs that have made the decision to have a strategic proactive approach to lighting control. They typically select a lighting control technology and invest in at least one dedicated lighting control resource to fully understand the solution, work on developing a marketing presence and most importantly, they train their salespeople and agents on how to position the technology with end customers, specifiers and electrical distributors. As the number of lighting OEMs that convert to implementing a proactive lighting control strategy increases where they embrace an interoperable open standard like Qualified Bluetooth Mesh, it will gradually strengthen the ecosystem and its influence over specifiers to include the standard in their next project, which will further increase the rate of adoption.

About Wired Technologies as an Option for a Future-Proof Installation

In contrast to the widely discussed wireless solutions, there are also some very specific proposals that don't leverage radio frequencies: bus systems via a controlling cable, power line carriers, or Power-over-Ethernet (PoE). Some of these approaches are promoted as more reliable than wireless systems. But we need to ask ourselves if all of these systems are truly competitive.

The wired technology that has been getting the most attention in the past few years has been PoE. Typically, for a disruptive technology to be successful, it must also embrace or bridge the existing one. In the case of lighting control, what would be difficult to fundamentally change in the short term would be the LED driver. Lighting OEMs must have flexibility in their source of LED driver

options with different output power, output current, output voltage and form factor. However, with PoE, traditional LED drivers cannot be leveraged where options are still very limited for PoE compatible LED drivers. Furthermore, the PoE switches, which power the PoE LED drivers are still very expensive and limited in how much power they can provide to multiple luminaires. Finally, there is no escaping the fact that the IT department will need to be involved and supportive of a PoE system, which adds another level of complexity. Since Bluetooth was initially developed to be a very reliable wireless cable replacement, for PoE to carve a niche in the lighting control arena, it needs to provide some additional value that leverages its strengths, such as high data rates. With PoE, luminaires can also process and send audio and video data with microphones/speakers and IP cameras where lighting and security can be combined or to enhance the functionality of a video conference room.

The other wired protocol that is evolving with the needs of the market is DALI and in particular DALI 2.0. As examples, DALI 2.0 is improving interoperability of the protocol to minimize issues during installation. The upgrade also incorporates the use of occupancy and daylight harvesting. Advanced functionality such as supporting tunable white from a single DALI address is now also part of the standard. But the likely greatest impact to the lighting OEM and lighting control markets is the upcoming release of DALI driver diagnostic standard that will also include power metering. This will enable all LED driver manufacturers to leverage a common interface and protocol to develop the next generation of LED drivers.

Conclusions

An increasing number of companies are starting the process to adopt Qualified Bluetooth Mesh. The advantages the protocol will bring to the lighting industry and building automation as a whole are clear. An interoperable, low-cost, simple, reliable, scalable and secure standard that has the potential to bring unity and clarity to lighting OEMs, specifiers and building managers. Qualified Bluetooth Mesh was specifically developed to address the drawbacks of existing protocols, which had forced several new lighting control equipment vendors to create their own proprietary solutions. However, this had caused confusion in the lighting industry where many lighting OEMs have been waiting on the lighting control technology dust to settle before investing proactively. It will still take a couple of years before the Qualified Bluetooth Mesh ecosystem reaches critical mass. However, the opportunity cost for lighting OEMs to wait further may be too high as some of their competitors may already be investing before the dust fully settles. Now is the time to make the philosophical transition from "the first duck out of the pond gets shot" to "the early bird gets the worm". ■

References:

[1] Source: www.bluetooth.com

Materials, Manufacturing and Technologies for Designing Passive Cooling Devices

Until recently, incandescent bulbs and fluorescent lights were the dominant light sources. Today it's the energy efficient, durable and, in the meantime, cost effective, LED. But to achieve these attributes appropriate cooling is still necessary and due to progress over the last few years the need for active cooling solutions is limited to a few high power applications as long as the material and technology is carefully chosen. John Broadbent, Managing Director at Columbia-Staver Ltd., describes the different technologies and materials and gives practical advice on how to find the right solution for an application.

A decade ago when purchasing a light bulb there was just little choice, the incandescent bulb was pretty much all one could get. Recent developments have brought new options with the introduction of LED's. The light emitting diode (LED) bulb can operate for 20,000 to 50,000 hours, at least five times the length of any comparable bulb. In respect to energy consumption LEDs put all contenders to shame. Whilst purchase cost of these bulbs are a little bit higher, over the lifetime of the bulb dramatic savings can be made.

LED lighting can be used in a huge variety of applications that include simple domestic lighting, street lights and traffic control, building illumination, plant growth and even for curing some epoxy products. The LED has been successfully used in these applications, and many more, but in order to get the legendary longevity out of the LED technology, their critical junction temperatures must be maintained at all times and in all operating conditions. Maintaining this temperature

requires careful consideration of their thermal management requirements.

A large proportion of LED applications are deployed in the built environment and in urban settings with the need to adhere to strict noise limitations. It is no surprise, therefore, that over two thirds of LED cooling solutions are based on natural convection passive designs.

Only a few specialist higher power applications may need more sophisticated cooling solutions using pumped liquid cooling or fans to increase the air speed. Therefore, the scope of this article is on natural convection cooling solutions and will describe heat sinks based on die-casting, cold forging and heat pipe assemblies. Aesthetic aspects, which can often be achieved using various surface treatments in different colors and or textures, are also considered, as the solution is often visible.

Die Casting

Die cast heat sinks are particularly well suited for the high volume, low cost LED market, where solutions are limited in the amount of output power. Whilst this manufacturing method is low cost, it does facilitate the inclusion of multiple design features. Once incorporated into the die cast mold, these features are repeated for each casting cycle. Design engineers can make use of this technology feature to design heat sinks with additional functionality.

Die-casting requires the production of an open and shut mold or die, into which molten metal is injected to form the component. Once the metal is cooled down enough, the die is opened and the component is removed. The die then closes, and the process gets repeated to produce the next component. This allows for high rate of production and can be further increased by duplicating the component within the mold thereby casting more than one component at a time. Die-casting can maintain excellent repeatability of features to high mechanical tolerances.



Figure 1: Example of a die cast heat sink and its application. Die cast heat sinks are the low cost solution for mass production of standard products

When selecting the casting material to be used for the heat sink, two major groups of alloys can be considered.

Best suitable alloys for die casting:

- Silicon (Si) based alloys
- Zinc (Zn) based alloys

In the first group of silicon (Si) based alloys, it is in particular, ADC12. This alloy is attractive to heat sink designers due to its excellent casting properties; its ability to fill narrow cavity features such as ribs and fins. ADC12 also offers an attractive thermal conductivity of 90 – 96 W/m-K and can be easily powder coated or otherwise treated to enhance its performance or appearance after casting.

The second group of zinc (Zn) based alloys are often referred to by their original trademark of Zamak, with Zamak 3 being the most widely used alloy in Europe. Whilst the Zinc based alloys do offer a slightly more favorable thermal conductivity, ranging from 105 – 113 W/m-K. The density of the zinc based alloys in the range of 6600 kg/m³ in comparison to around 2700 kg/m³ for aluminum silicon alloys will increase the component weight by a factor of 2.4. The material is more aggressive, causing faster tool wear and has a harder to treat surface. These factors often put the zinc-based alloys behind the aluminum-based alloys as the prime choice for heat sink designers.

A third alloy family, which is not widely used for pure heat sink

applications, but needs mentioning for reasons of completeness, is the group of magnesium-based alloys. These are predominantly used for applications, where weight and structural strength of the components are critical considerations.

Cold Forging

When the thermal performance of the heat sink demands thermal conductivity in excess of 120 W/m-K, die cast solutions cannot be considered. Cold forging can be done with a range of materials 120 W/m-K and above. The technology can also offer large diameter heat sinks with tall high density fins. Designs can also offer orientation independent solutions for high volume- low cost applications.

For the production of these parts, a tool is made in the shape of a female impression of the

component. In a high force press the selected material is forced to reflow into the tool by the sheer amount of pressure exerted by the press. As well as forming the heat sink shape the process re-aligns the grain structure of the base material leading to an improvement in thermal conductivity in the fin areas. The process ensures that no air bubbles or porosity (often found in die casting) will be present.

The most common shape is a series of pillars mounted onto a base section. Due to ease of tool manufacture the pillars are often a round section pin giving these heat sinks their common name of pin fin heat sinks.

By wire eroding the tooling, more elaborate shapes are possible such as squares, triangles, rhomboids and diamonds. At the design and tooling stage additional



Figure 2: Cold forged aluminum heat sinks offer better thermal conductivity than die cast products

features such as larger bosses for screw threads or omissions of patterns can be incorporated into the tool, the pitch of the pins can be variable, and non-symmetrical if required.

Many aluminum alloys can be used for cold forging, starting from low alloy numbers in the 1100 range right up to aircraft grade alloys in the 7xxx range. The standard extrusion grades in the 606x range of alloys are also included, and offer thermal conductivities exceeding 170 W/m-K.

In conclusion both die cast and cold forged heat sinks have their place. Both technologies have advantages and disadvantages. Cold forged components have a higher thermal conductivity and the finished material is structurally stronger than a die casing. However, the intricate features possible in a die cast part are simply not possible using cold forging.

Heat Pipe Assemblies

Die cast, cold forged and indeed extruded heat sinks can only function up to the limits imposed by the thermal characteristics of the material that they are made of. The thermal conductivity will eventually reach saturation and the only way to extend performance would then be by adding forced air that comes with its associated cost, noise, weight and reliability. The most flexible and often the most effective LED cooling solution is the Heat Pipe assembly.

Heat pipes can offer thermal conductivity many orders of magnitude more than the materials of the other solutions. Following furnace sintering the heat pipes are malleable, enabling 3D designs that can take the heat to be transported in any direction away from the light source. Passive solutions rely on surface area rather than airflow rate and heat pipe assemblies are no different. Heat pipes can be fitted with a large number of lightweight fins designed in such a way as to maximize performance for a given application. They can move large amounts of heat over distances not possible by conduction. Heat pipes are passive, two-phase based thermal super conductors. The working principle is that a small amount of working fluid, (mostly water) is evaporated in the heat input region. This vapor then travels at almost the speed of sound along the pipe towards the heat output region. Because the heat output area is cooler the vapor condenses. This condensed working fluid then gets returned to the heat input region in the wick structure of the heat pipe by capillary action. This wick structure is on the inside surface of the pipe and can be sintered copper particles or wire mesh. The return of the liquid to the heat input area is aided by gravity and as such this is a key component in the LED solution design.

The heat pipe has a Vacuum inside, therefore this evaporation process with water can start at temperatures as low as 4°C. It should be noted that a heat pipe is simply a highly efficient heat transport device and must be supported by adequate means of heat dissipation at the heat output area. This can be achieved by attaching the heat output or condenser area to an extruded aluminum heat sink or more commonly in LED coolers by attaching aluminum or copper fins directly to the heat pipe in appropriate numbers. Their number is largely determined by the thermal requirements of the particular application.

Due to the very high thermal conductivity of the heat pipes and the fact that through the provision of fins, a large amount of surface area can be provided without an excessive weight penalty, in high power applications, heat pipe based solutions can outperform both die cast and cold forged heat sinks. Heat pipe based solutions are largely used where high-powered LED spot lights are deployed into remote locations where space is less of an issue.

Surface Treatment

In some cases, particularly when the heat sink is visible to the end user, appearance can be very important. In other cases, protection of the solution from the elements or the environment is paramount. This aesthetic appearance or protection can be provided by the surface treatment applied to the finished solution. When considering surface treatments, the base material of the heat sink needs to be considered.

For aluminum based cold forged heat sinks, the most common surface treatment is anodizing. Anodizing is an electrochemical process that converts the metal surface into a decorative, durable, corrosion-resistant, anodic oxide finish. The process is available in a wide range of colors that can be specified from the RAL color chart. Often the color selected is black because this not only provides protection but it also changes the emissivity of the unit, thereby potentially improving its performance.

When looking at surface treatments for die cast heat sinks, and as an alternative to wet paint, powder coating is a very popular choice. It offers consistent finishes with a selection of RAL colors and surface textures, ranging from completely smooth to a more textured finish.

The powder coating process is based on charged powder particles being attracted to the components bearing the opposite charge.

Figure 3: Heat pipe assemblies are often used for cooling architectural lighting units because they offer the lowest thermal resistance of any passive cooling solution





Figure 2: Anodizing is a common surface treatment method for architectural aluminum elements and cold forged aluminum heat sinks. It offers a broad range of fancy colors (image from LpS 2017- © Luger Research e.U.)

GEORG BECHTER

Material/ Process	Die Casting	Cold Forging	Heat Pipe Assemblies
Die Cast Alloys: Si based AL Alloys (e.g. ADC12)	Density: 2740 kg/m ³ ; Thermal Conductivity: 96 W/m·k		
Die Cast Alloys: Zi based Alloys (e.g. Zamak 3)	Density: 6600 kg/m ³ ; Thermal Conductivity: 113 W/m·k		
Aluminum Alloys 1000 range		Density: 2700-2710 kg/m ³ ; Thermal Conductivity: 218-243 W/m·k	
Aluminum Alloys 606x range (e.g. AL6063)		Density: 2700 kg/m ³ ; Thermal Conductivity: 200 W/m·k	Density: 2700 kg/m ³ ; Thermal Conductivity: 200 W/m·k
Aluminum Alloys 7xxx range		Density: 2720-2890 kg/m ³ ; Thermal Conductivity: 115-222 W/m·k	
Copper (e.g. C101)			Density: 8920 kg/m ³ ; Thermal Conductivity: 391 W/m·k

This leads to a very good and even coverage of even the most complex surfaces, after particle coating the unit requires an oven curing process in which the powder particles are melted and form the finished coating.

A final alternative is the use of electrophoretic painting. This process was developed by the automotive industry and is also referred to as e-coating or electro-painting. It is very similar to powder coating, but liquid paint with an electric charge is used instead of powder. All remaining process steps are the same as when using powder coating. This process is widely used when coating many different types of heat exchangers, and is therefore ideal for the coating of heat pipe based LED coolers, utilizing the process' main advantages of being able to cover even the smallest gaps

and corners of the parts and providing a coating with unrivalled environmental protection. A wide range of different colors on the RAL chart are available.

For completeness, metal coatings such as Nickel plating should be mentioned. However, it has to be considered that due to their complexity and cost, they are not widely used as finishes for LED coolers.

Summary and Conclusions

Many different solutions are available and several manufacturing possibilities can be applied to LED cooling, but there is no one-fits-all solution. The actual application, the power, the physical size and the working environment would all need to be considered before a solution could be presented.

The table below shows the relative thermal properties of materials and their suitability for various manufacturing techniques.

In conclusion, it can be said that a sound knowledge of material properties and process technologies is the key element to find the best, cost-effective solution for any application. It is therefore important to select a supplier that offers a full range of thermal design services, including CFD, thermal design, mechanical design and design for manufacture for a range of bespoke thermal products such as LED coolers, heat sinks, heat pipe assemblies, conduction cards and liquid cold plates as well as cooling systems. ■

Table 1: Relative thermal properties of materials and their suitability for various manufacturing techniques

Interactive Lighting Control is Opening New Doors for LED Applications

Advancements in lighting control technology are allowing for sophisticated interactivity in LED mapping. These new technologies are bridging the gap between lighting control and AI, with the ability to analyze and map data input (such as audio) in real-time. Installations driven by interactive LED control technologies have their place in a variety of application spaces. Manjinder Benning, Founder and CTO of Limbic Media, explains how this new technology works, what its applications are, and what the future of interactive lighting control looks like – not only for end-users, but also for lighting designers and technicians.

Figure 1: Interactive lighting, backed by artificial intelligence, leads to completely new experiences in many different applications by providing an exceptional atmosphere, not known until now

Interactivity is a growing feature of consumable technology. Public spaces - from shopping malls to schools, hospitals, and entertainment venues - are increasingly designed with human-centric, interactive approaches. Designers are recognizing the value of interactive technology in driving

traffic, educating, healing, and entertaining over platforms that engage and connect people on a multisensory level.

This trend has only begun to influence LED applications - and new technologies are making interactive LEDs more sophisticated and accessible

than ever before. This article describes the relevance of interactive technology in various industries, the existing state of interactive LED mapping, and outline an autonomous LED mapping technology that expands the current range of interactive LED applications.

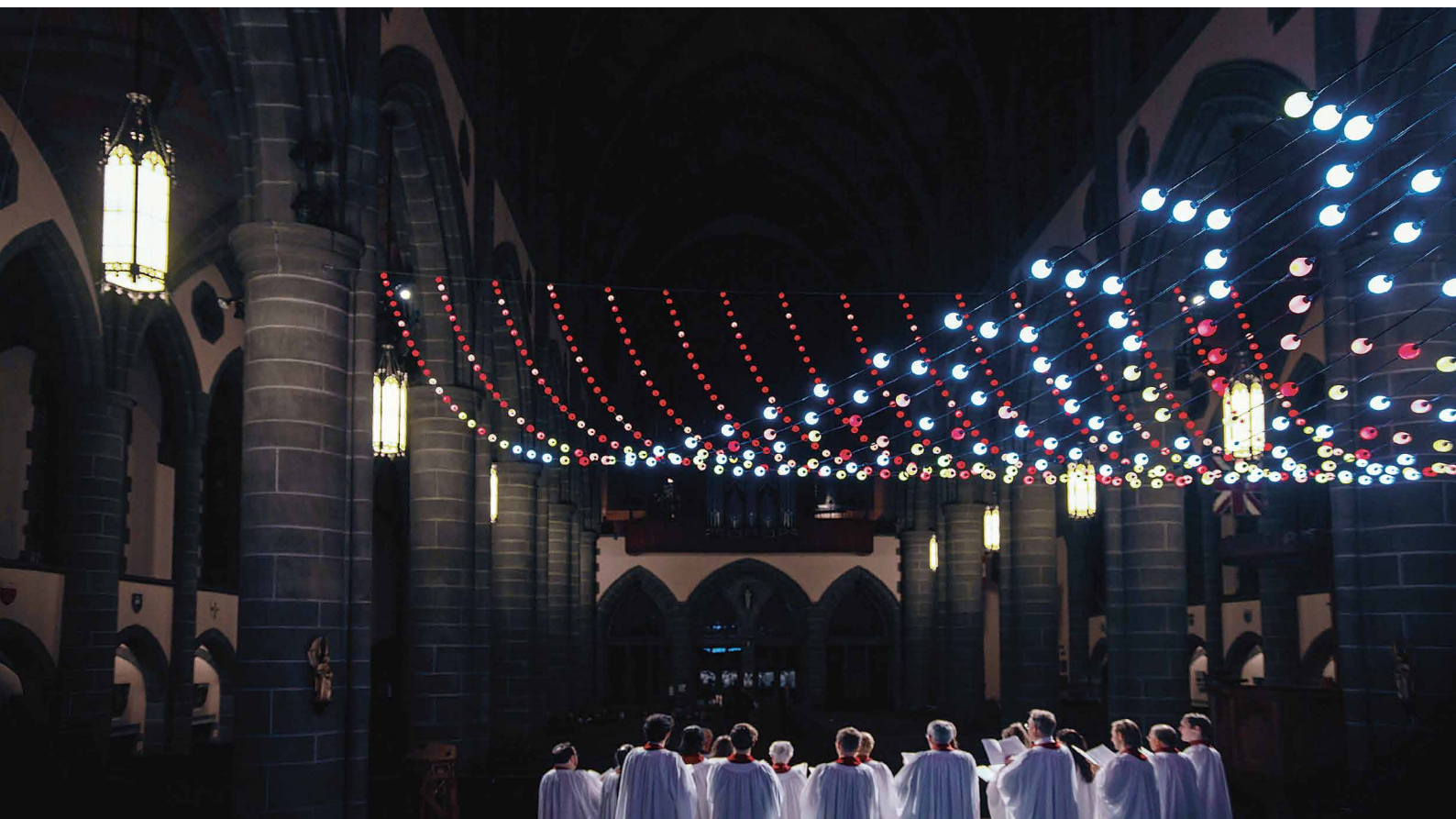

Interactive Technologies Are Growing in Demand

The digital age has allowed anyone to curate information. With limited resources, millions are able to publish content and connect to global networks. People expect a greater level of participation and control over their digital environments. Much of our non-digital experiences remain unchanged despite this shift in digital experience. As a result, many facets of the real world struggle to stay relevant: Retail centers are losing revenue, university enrollments are declining, and community-centered activities are struggling to survive in the Netflix era.

Interactive technologies are becoming more common across spheres of public and private life to stay relevant and increase revenue:

- Voice-controlled smart hubs are growing in popularity in private residences, creating a common interactive interface for a number of domestic devices
- Shopping malls are embracing interactive technologies, such as virtual try-on mirrors, interactive marketing displays [1], interactive LEDs on building facades (Singapore's Illuma [2]), virtual immersive experiences, and robotics [3]
- Some theaters are testing multisensory experiences by manipulating temperatures, scents, and tactile experiences
- Education institutions of all levels are introducing more hands-on, interactive learning approaches, such as STEAM [4]

Implementation of these technologies through public art, entertainment, and education has uncovered many benefits. For participants, multisensory input elevates entertainment value, or conversely, calming synesthesia-like effects. It also appeals to various learning styles [5, 6, 7] in educational settings. Interactive technologies benefit retail-focused spaces by increasing foot traffic and brand loyalty through

customer engagement. They also transform underutilized civic space into social hubs, improving public safety and revitalizing neighborhoods.

It is clear that interactive, multi-sensory experiences are poised for rapid growth globally. Traditional sectors such as retail, entertainment, and education are struggling to catch up to our world's digital transformation. These sectors are utilizing interactive technologies to bridge the gap between the digital and physical world. Modern LED technologies play an important but underutilized role in interactive experiences.

Background

Existing interactive LED technologies are limited

LED technologies have been underutilized in the interactive marketplace for a number of reasons: interactive LED technology has been limited to simplistic sound-to-light interaction - and even in this application, achieving interactions is a laborious and expensive process.

Until now, interactive LED technology has been largely realized through automatic music-to-light mapping. Driving light fixtures from musical input, known as light organs, was first presented in a 1929 patent [8]: The patent mechanically models light automatically from audio frequencies. A 1989 patent [9] employed electrical resonant circuits to respond to low, medium, and high frequencies. Modern, digital music-to-light mapping systems have a number of advantages over these early systems. Computers can digitally process audio in real-time and extract control signals (energy in certain frequency bins, or tempo, for example) to more meaningfully map lighting schemes.

Some modern lighting control equipment, including hardware and software lighting consoles and VJ software systems, provide designer interfaces to map beat or

frequency-based control signals to parameters that modulate lighting. For example, designers can map the amplitude of a 60-100 Hz frequency bin to DMX fixture brightness. This would create a visual "pumping" effect in response to bass.

This paradigm of manually connecting simple control signals - most often derived from the incoming audio signal frequencies - is closely modeled after the original light organ techniques from the 20th century. There has been little innovation in this field since its inception. In addition, mapping light interactions using this method is time-consuming for designers, and as a result, costly for consumers.

Potential beyond music-to-light mapping

Beyond music-to-light mapping for LED systems, there is great potential for other interactive data inputs. There has been an explosion, in recent years, for low-cost sensor technologies coupled with easy-to-use microcontrollers such as Raspberry Pi. These technologies are capable of sensing data inputs from physical environments more cheaply, accurately, and easily than previously possible.

In terms of LED interactivity and mapping, data inputs could include:

- Audio
- Voice recognition
- Motion detection
- Data streams (from social media or other live inputs such as weather patterns)

Some commercially-available software products, such as the Isadora system, enable complex input/output system building. This allows designers to map a variety of inputs (such as sensors) to multimedia outputs, such as projections or audio effects. Again, using LEDs as output is largely unexplored.

Although very well designed and capable of dealing with complexity,

existing systems still require expert designers to inform mappings between inputs and outputs, and to direct visualizations as inputs change and evolve. No existing technology has been capable of autonomously listening to data input, monitoring output, and learning to make intelligent decisions to map LED visuals over time.

This article discusses a new paradigm in interactive LED control: artificially intelligent systems that eliminate the programming expertise, time, and cost required to create advanced interactive LED experiences. Such a system intuitively recognizes distinct input features (from audio or otherwise) in real-time. Input features are mapped according to human-

based preferences, without direct human control. This makes interactive LED applications more accessible and less costly to a variety of industries seeking interactive solutions, while elevating user experiences.

Description of the Technology

LED control that maps inputs and drives output autonomously

Imagine an LED installation that intuitively “listens to” audio or other real-time data input and adapts accordingly, learning over time, with no human intervention. This new approach to interactive LED mapping uses an “intelligent” system based on mainly three key elements.

The system is composed of:

- A temporal correlation unit (110). This acts like a brain, inputting, processing, recording, retrieving, and outputting data. Data inputs can include audio (either from a microphone or line-in audio), motion detection sensor inputs from a camera, data streams (from weather patterns, the stock exchange, tallied votes, or social media, for example), or interfaces that request data input from an audience
- An oscillator (140). This perturbs the inputs, introducing variation to the LED output. This produces light interactions that are lively, dynamic, and less predictable to the viewer
- A signal mixer unit (150). This mixes input signals in various ways to create different outputs

Figure 2: Interactive LED system architecture: Visualization of a control system capable of autonomous LED input/output mapping

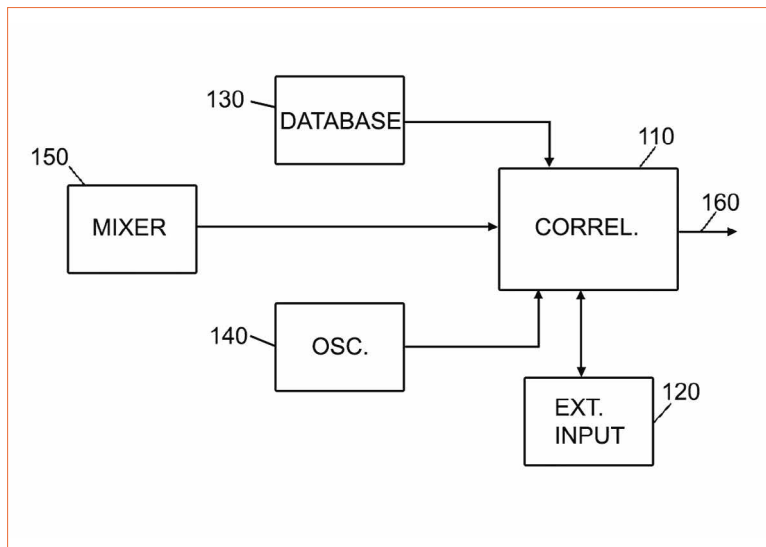

The temporal correlation unit references input signals for distinct features, and determines how the oscillator and signal mixer unit behave in response. The system also determines how the output signal spans through a specific color space.

Figure 3 expands on potential external inputs (120). As with prior technology, the system analyzes binned frequency content (210, 235) and time domain envelopes (215). In addition, the system recognizes and classifies higher-level musical features (220).

Figure 3: Real-time inputs to Interactive LED system

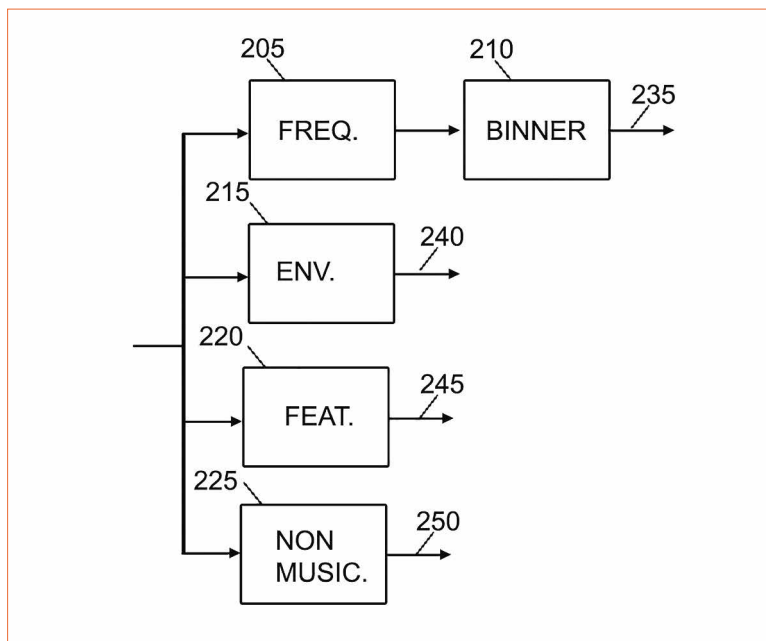

Some examples include:

- Percussion/other specific instruments
- Vocal qualities
- Musical genre
- Key
- Dissonance and harmony
- Sentiment
- Transitions (e.g. from verse to chorus)

The system also interprets non-musical data inputs (225) in real-time. This includes non-musical audio features, such as speech recognition or environmental sounds (rain, wind, lightning, or footsteps), or the other non-audio data inputs previously described.

Features can be reflected as LED-mapped output in many ways.

LED parameters such as motion, color palette, brightness, and decay adapt to reflect specific data input features. This creates LED displays that are more intuitively-mapped to human preferences than previous light-mapping technology. The system's ability to map intuitively and autonomously in real-time heightens the users' multisensory experience and potential for LED interactivity.

Referenced Data Input Determines LED Mapping

An intelligent LED mapping system relies on referenced input signals. The system analyzes new data input for familiar features based on referenced input stored in the temporal correlation unit. Over time, the system optimizes database searches. This allows it to predict input features from audio or other data streams, and create a more intuitive, real-time visual LED output on its own.

When the temporal correlation unit has been adequately trained, it can predict human listeners' preferences, and map LEDs accordingly for musical, other audio, and non-audio inputs. This system provides a more intuitive, engaging user experience with no need for customized LED programming knowledge or real-time human control.

The temporal correlation unit trains itself to map output effectively in three ways.

First way of the system to train itself

The system acts as a neural network by comparing new data inputs to similar inputs stored in the system's database. New output features are modeled after those of referenced inputs. This allows the system to quickly reference previous lighting output configurations rather than creating them on the fly. Previous technology requires a technician to manually choose which lighting cues to load and when, whereas this system automatically chooses which cues to load and when.

Neural networks can also be supervised. In a supervised neural network, the system recognizes specific data input features that indicate audience approval of the LED mapped output. These input features could include: manual switches, face recognition, or voice recognition that indicate emotional states. This serves to further refine the system's output choices according to human preferences.

Second way of the system to train itself

The system can also utilize evolutionary algorithms. Evolutionary algorithms are used in artificially intelligent systems - they are modeled after selection mechanisms found in evolutionary biology (firefly attraction, ant pheromone trail setting, and bird flocks, for example) to optimize data searches. Evolutionary algorithms, such as a genetic algorithm, allow an LED control system to independently find and select the most effective lighting outputs without human control.

As with a supervised neural network, the system governed by genetic algorithms seeks specific audience cues that suggest approval of the mapped LED output. This serves as a fitness function, training the temporal correlation unit to respond to real-time input signals.

Third way of the system to train itself

Similarly to evolutionary algorithms, a system can utilize interacting intelligent agents. Agents also mimic natural patterns in code by responding to specific, predefined rules (e.g. a specific frequency produces a certain color space). Each agent applies a set of rules to generate temporal sequences for LED mappings, again seeking audience cues to train the system how to respond appropriately to input.

Agent rules can be parametric. For example, rule parameters are determined by the physical arrangement of LEDs in 2D or 3D installations. A suite of techniques known as nature inspired algorithms, which are modeled after naturally-occurring patterns, are a credible source for generative content when considering lighting output. This approach works particularly well with large numbers of LED pixels.

Implications of Technology

Implications for industries and end-users

An intuitive method of mapping LEDs according to human preferences means that multisensory, interactive lighting are more immersive and emotive than ever before. An intelligent,

Figure 3: Fascinated youths tinkering with an interactive light in front of the Showmans Jazz Club in New York City



autonomous LED control system has many benefits and applications for end-users and various sectors.

Benefits for end-users:

- Educational programs can use such systems to leverage multisensory, interdisciplinary curriculums that address various learning styles
- Holiday, architectural, and other lighting companies that already employ LED technologies, can use the system to employ a more interactive, human-centric approach to design
- Retail centers can use the system's interactivity, particularly live social media hashtags as data input, to attract customers and leverage brand presence online
- Cities can incorporate the system in their efforts to revitalize public space by:
 - Investing in interactive, public art using LEDs
 - Visualizing data gathered through smart city initiatives
 - Attracting foot traffic to business areas
 - Improving public safety
 - Place making and creating community focal points
- Clubs, venues, and AV teams can quickly and effectively create improved visual effects for live performances and DJs
- Public centers and exhibition venues that adhere to redesign cycles can adapt the system with changing data input types and LED configurations to refresh displays year after year
- Non-technical users are able to access sophisticated interactive technology without custom programming or design knowledge
- Users can avoid the time and cost associated with creating and maintaining interactive LED displays
- LED displays can be controlled and scaled across multiple locations at a lower cost

Implications for technicians

It is often assumed that technological advances, particularly using AI, have the potential to destroy jobs.

The described system simplifies or removes the programming process, making the technology more accessible and affordable than previous interactive LED technologies - but this does not necessarily imply job obsolescence for lighting designers and technicians. The technology will only change and improve the state of the art in the future, providing a number of benefits for industry professionals.

Benefits for professionals:

- Provides a sophisticated tool for the lighting designers that can be used in conjunction with existing professional lighting protocols such as DMX
- Saves lighting designers programming time
- Allows designers to scale large projects at a lower cost
- Opens the door to a wider variety of LED applications in industries outside the current status quo
- Allows designers to manipulate lighting schemes with data input other than music
- Allows designers to improve or incorporate audience interactivity

Conclusion

Interactive technologies are poised for global growth, allowing various industries to offer engaging, multisensory experiences in non-digital settings. Applying interactivity to LED technologies opens a variety of doors into a number of sectors looking to attract, engage, and educate communities in settings that struggle to stay relevant in our digital world.

Until recent advancements in LED control technology, mapping data input to lighting design has been limited to audio input using age-old light organ techniques. While low-cost and easy to use microcontrollers such as Raspberry PI have opened new doors in LED mapping, the process still requires skilled lighting designers and programmers. The cost and time associated with creating and maintaining interactive LED displays using these methods has made interactive LED applications

costly and inaccessible to a variety of industries and audiences.

A new technology, outlined in "System and Method for Predictive Generation of Visual Sequences", addresses these barriers to new LED applications by controlling LED interactivity autonomously yet elegantly. The system analyzes data input, including music, non-musical audio, and non-audio data streams for distinct input features. Input features are mapped into distinct LED output parameters based on human preferences, and indexed into the system's database. This indexing allows the system to autonomously predict upcoming data input and intelligently refine its output over time.

The system's design avoids the need for timely human programming and maintenance, creates LED mapping that looks aesthetically detailed and intuitive, and allows real-time interaction from a variety of data inputs. This has clear benefits to the LED lighting industry: it opens doors to new applications in various sectors seeking interactive solutions for consumers. It creates heightened multisensory, end-user experiences. It offers a sophisticated tool for lighting technicians and professional designers. ■

References:

- [1] "6 Futuristic Displays That Will Change Your Idea of 'E-Commerce.'" Time Magazine. 7 July, 2015, <http://time.com/3938488/retail-displays/>
- [2] "Illuma/WOHA." Arch Daily. 17 May, 2010, <https://www.archdaily.com/59896/illumawoha>
- [3] "Softbank Robot Pepper Sells Out In A Minute." The Wall Street Journal. 22 June, 2015, <https://blogs.wsj.com/japanrealtime/2015/06/22/softbank-robot-pepper-sells-out-in-a-minute/>
- [4] Education Closet - What Is STEAM, <https://educationcloset.com/steam/what-is-steam/>
- [5] Johnson, Gretchen L., and Edelson, Jill R.. "Integrating Music and Mathematics in the Elementary Classroom." Teaching Children Mathematics, Vol. 9, No. 8, April 2003, pp. 474-479.
- [6] Wilmes, Barbara, Harrington, Lauren, Kohler-Evans, Patty, and Sumpter, David. "Coming to Our Senses: Incorporating Brain Research Findings into Classroom Instruction." Education, Vol. 128, No. 4, Summer 2008, pp. 659-666.
- [7] Kast, Monika, Baschera, Gian-Marco, Gross, Markus, Jäncke, Lutz & Meyer, Martin. "Computer-based learning of spelling skills in children with and without dyslexia." Annals of Dyslexia, 12 May, 2011, DOI: 10.1007/s11881-011-0052-2
- [8] Lewis William Turnor, Thomas George. "Color Producing Device." US194602A, 5 June 1929, <https://patents.google.com/patent/US194602A/en>
- [9] Snavelly, Donald. "Color Organ Display Device." US4928568, 4 Dec. 1989, <https://patents.google.com/patent/US4928568>

acal^{bfi}

Light measurement has never been easier
Goniometers for any luminaire up to 1.5 meter

VISO
SYSTEMS

LabSpion



LightSpion



LabFlicker

**NEW: Handheld flicker
measurement device**

See
the products
at booth A21
LpS 2018
in Bregenz



Complete characterisation of your luminaire within 30 seconds.
Simply measure lumen, beam angle, CRI, colour
temperature and lumen per watt and export the
data easily to IES / LDT and generate your custom PDF report.



Approaching the Spectrum of the Sun

The evolution of mankind is the evolution of the capability to make and control artificial light. This ability found its culmination with LED lighting: Today it is possible to almost perfectly recreate the spectrum of the sunlight at every time of the day and at any climatic condition. One of the pioneers in this field is Seoul Semiconductors. Marc Juarez, Technical Director Europe at Seoul Semiconductor, the innovators of the SunLike technology, explains this technology, the advantages and the future prospects.

Nothing has changed life more than the introduction of artificial light, beginning with the first man-made fire to gas lanterns, electrification with Edison's incandescent bulb to, finally, LED lighting today. While at the beginning of the "LEDification" increasing efficiency was the major concern, in the last years industry began to (re-)consider light quality to be the most interesting and important property and their proponents began to explore the opportunities of LED technology for shaping the spectrum of the light. So we have to admit that LED industry is completely changing the way we interact with light and for

the 1st time in human history we are close to reproduce the complete sunlight spectrum during whole day with a simple bulb at home. The following paragraphs will discuss the history and co-evolution of humans and artificial light, will compare different technical approaches to generate white light, and demonstrate the fantastic opportunities of shaping the LED light spectrum as close as possible to the spectrum of natural sunlight explaining the positive effects on health and well-being.

History – Co-Evolution of Humans and Artificial Light

Let's make a review on the electric lighting industry history and check the key technologies that shaped it. We will find that three major technologies changed the market and the industry during the last 100 years. Which ones were the most important motivations for the changes to happen?

For millions of years the human eyes have been shaped, adapted and evolved according to the light of the sun but in the last 200 years the things have changed a lot.

Starting in the latest years of the XIX century with the incandescent bulb discoveries from Thomas Alva Edison, the incandescent light bulbs

Figure 1:
Evolution of the light

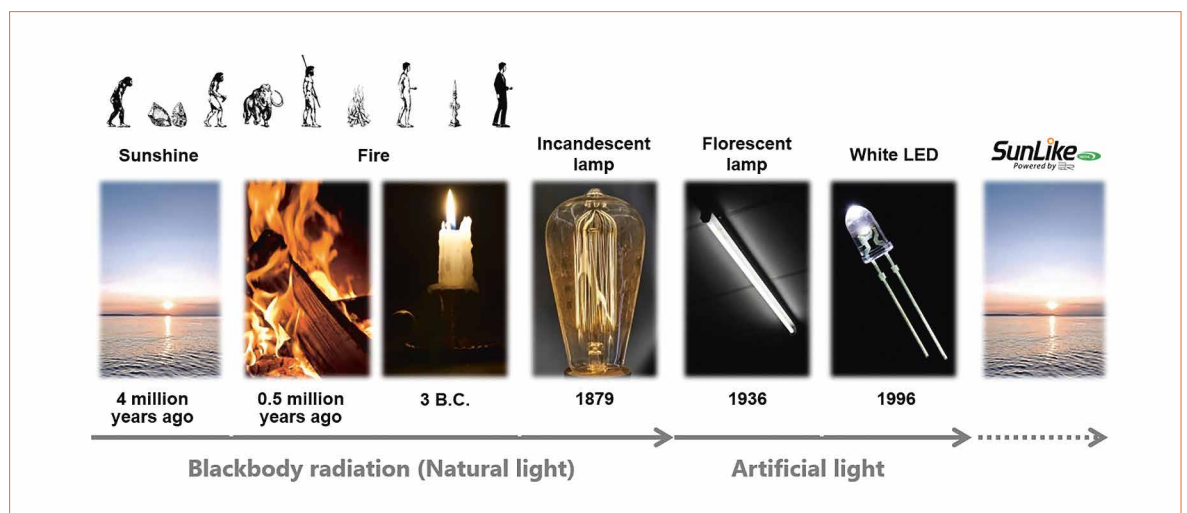

have given us the benefits to develop tasks during the night or to work and live inside the buildings with a warm and a much healthier technology than the oil or gas lamps. - The race for a more efficient, lower cost and more durable lighting technology had started.

Incandescent bulbs are still with us today and what is interesting is to see how a handful of companies dominated the lighting world for more than 50 years in past but this is coming to an end.

It was around mid-thirties that fluorescent technology emerged and became more and more used until it overpassed the incandescent technology around second half of the 20th century. This newer technology brought to people a more efficient light and a more durable one, but also, some known drawbacks like the usage of mercury, unpleasant hue and cold colors with many versions with big flickering issues.

The third big change in lighting technology was the discovery and development of the LEDs. Starting in nineteen sixties with red LEDs and in nineteen nineties with Blue LEDs and phosphors to create white light the 3rd lighting revolution was started.

From this moment, the race to increase the lm/w was driven by R&D teams that could produce new products that performed better than the previous ones with huge investments in R&D from companies and governments that were thinking that LED technology one day could lead the world of lighting and they were right!

The Evolution of LED Technology

After the 1st wave of LED technology looking to achieve a similar efficacy than fluorescent systems many companies and governments invested heavily in the manufacturing process in order to bring down the costs and

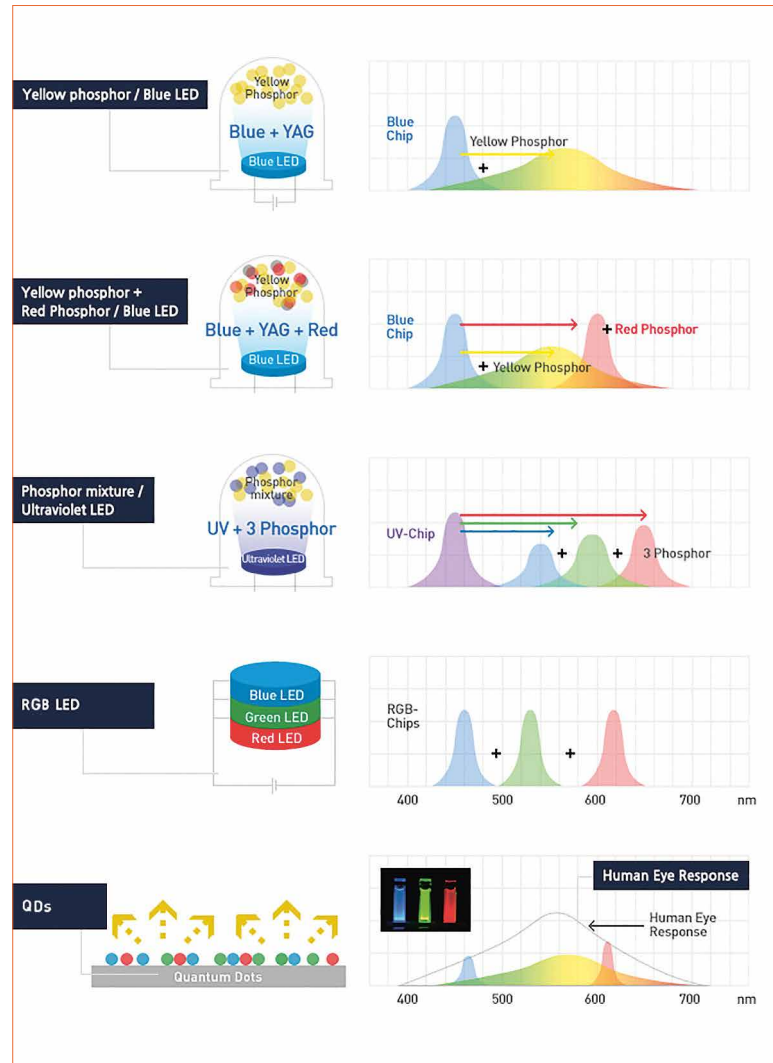

Figure 2: Comparison of basic technologies for making white light [1] - blue LED + yellow phosphor (a), blue LED + yellow and red phosphor (b), near UV + 3 phosphors (R,G,B) (c), combination of blue, red and green LED chips (d), blue LED chip + Quantum dot phosphor (e)

increase the volumes to penetrate the consumer markets and keep developing a more efficient solutions. During this period a big battle was taking place in the market between new players and old historic giants for the control of this new technology and the lighting market. Who was the winner? The customer! Today we can get very long lasting LED solutions at very low cost and high profitability for the consumers and the environment with a big reduction of CO₂ emissions.

In a race for quality of the light trying to reach the same spectrum as the sunlight with LEDs and to get all the benefits related to it, like perfect color reproduction and also the non-visible effects of the sunlight. High technology companies are developing key products that can achieve the sun spectrum.

The way to approach the sunlight spectrum with LEDs is different from manufacturer to manufacturer, some players use violet LEDs with 3 phosphors (Red, Green, Blue) that is demonstrated the closest solution to the sunlight spectrum. Some others use a blue LED with multiple phosphors that can achieve higher lm/w than a violet LED but spectrum have a non-covered area around cyan color. Some others use multiple single LEDs of different wavelengths to cover all the spectrum but cost, control and system becomes very complex (Figures 2a-e).

Light quality of different LED technologies

When analyzing the different high quality lighting available products in the market at 3000 K CCT we can see that the spectral power distribution (SPD), similarity to natural sunlight spectrum and color

Figure 3:
Comparison of different
existing technologies
for highest quality of
the light

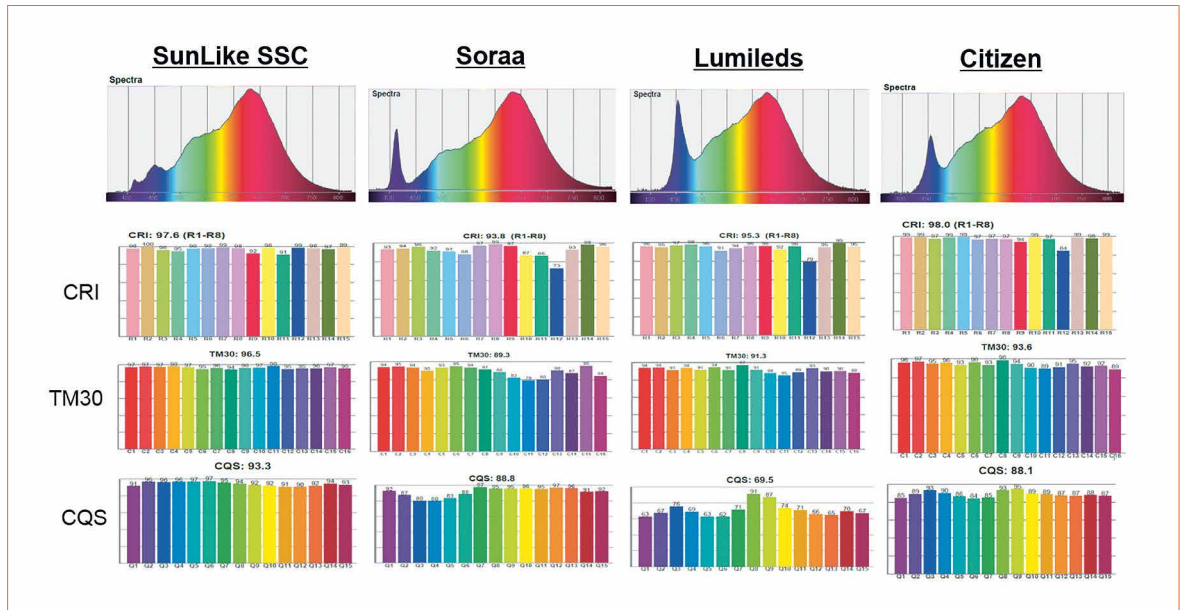

rendition are very different from case to case and main technologies used today are the violet (near UV) + RGB phosphors and the blue LED + yellow and red phosphors due to their efficiency and cost.

From the spectrums we can see that the SunLike and Sora both use a violet pump chips that are between 400 nm and 420 nm. T and the main difference is that SSC is capable to reduce the pump peak while Sora enhances it. On the other side Lumileds and Citizen uses a blue led pump in the range of 450 nm with a visible peak in the blue area and a less accurate color rendering.

The main differences between blue and violet chips are that the violet chips brings higher quality in color reproduction scales like CRI, TM30 and CQS for all the CCTs from 2200 to 6500 K and the spectrum is closer to the sunlight one. While the lumen/watt for the different solutions are quite similar and in the range of 110 to 130 lm/W being the blue pump options the higher in lm/W.

Non-photometric properties of the compared technologies

About the cost, we have to consider that the blue chips are the main volumes in the LED market today and then they are 20-30% lower cost just because of scale than the

violet chip that is just growing the volumes. That means that the expectation is that the violet chips will decrease in price when the volumes will grow and also will increase the lm/w in a similar way that happened with the blue chips and the Haitz's law and it's expected that in 3-4 years the main LED volume will be violet chips as the transition to Human Centric Lighting will be fully developed in the market.

Actually the new technology in a 3030 package can deliver up to 120 lm/W at 65 mA Tj 25°C with a violet pump while the 3030 CRI95 with the equivalent blue pump LED from the same company can deliver up to 130 lm/W at 65 mA Tj 25°C. This means that the efficiency in lm/w is around 8% lower. Compared with a lower CRI product, like a CRI80, the lm/w difference can be up to 45% as the latest CRI80 are achieving 220 lm/W.

Opportunities and Future Prospects of the New Technology

One of the important points of the new technology is that today it is possible to get the different spectrums of the sunlight at the different times of the day (early morning, midday, dusk,...) while with a blue chip LED solution it is not easily possible to do it for high CCTs (>4000 K) with full spectrum.

For example we could have a luminaire that integrates LEDs with 2, 3, 4 or more different CCTs and their related spectrums (depending on accuracy and complexity requested of the system). A controller could adapt the luminaire CCT and spectrum to the one the sun is providing in real time. Imagine in the early morning the luminaire is giving 2200 K CCT sunlight spectrum with no blue energy content, after, during the morning this value is moving and going up to 4000 K, at midday is delivering 6500 K with blue rich content like the sun and then going back to 2700 K later in the day without blue content to allow melatonin being generated during night like the sun. This will bring us a complete synchronization of our circadian rhythm like we were under the natural sun during the whole day [2].

Is the lumen/watt enough to determine if a luminaire or light source is better or worse? The answer is "NO" but legislators, regulators and the market in general should consider to apply corrective parameters related to quality of the light when delivering the efficiency qualification for a product.

We have to consider that efficiency is just a definition that is accepted by the market and in regards of the actual regulations from the EU for the labelling of lighting products the

	Non-directional		Directional	
	EEL	Lamps	EEL	Lamps
A ++	< 0.11	Best LEDs (including modules)	< 0.11	Best LEDs (including modules)
A+	0.11<EEL<0.17	Very good LED lamps and modules; Best LFLs and CFLs	0.11<EEL<0.17	Very good LED lamps and modules
A	0.17<EEL<0.24	Avg LEDs and modules; Avg CFLs and less efficient LFLs	0.17<EEL<0.24	Average LEDs and modules; average good CFLs
B	0.24<EEL<0.6	Less efficient CFLs and LEDs; Best halogen (extra-LV)	0.24<EEL<0.6	Less efficient CFLs and LEDs; Best halogen (extra-LV)
C	0.6<EEL<0.8	Less efficient conventional extra-LV halogen	0.6<EEL<0.8	Less efficient conventional extra-LV halogen
D	0.8<EEL<0.95	Best 230V and conventional halogen; Best incandescent	0.8<EEL<0.95	Best 230V and conventional halogen; Best incandescent
E	>0.95	Typical incandescent	>0.95	Less efficient 230v halogen and incandescent

Table 1: EU efficiency labeling requirements [3]

quality parameters of the light are missing as it only considers the lm/W and CRI that is being demonstrated that is not enough in order to take into account the quality of the products and the similarity of the natural light. For higher quality lighting and especially for a more human centric approach, it is desirable to change this practice.

Another impact of the actual efficiency definition is that the light has become a “cold” light since the

years of the fluorescent technology took apart the incandescent bulbs. It is being demonstrated that the heat in the light can have a big impact in human’s health. One of the main researchers is Doctor Alexander Wunsch [4, 5] from Germany that is driving several experiences in order to demonstrate this impacts. Then is very important a reconsideration of how we calculate the efficiency of lighting for humans as today is only based in the V-Lambda curve that skips any wavelength situated near the UV

or in the IR part. By this reason engineers and companies tried to optimize their products for the highest efficiency in the V-Lambda curve but forgetting about all other spectra’s of the sunlight like the full spectrum in the visible part, the near UV and IR parts of the sunlight spectrum as they don’t bring “efficiency” as defined today. But as Dr. Wunsch declared it will have health issues not using a natural and heat light as we spend most of our time under artificial “cold” light environments. A first step to

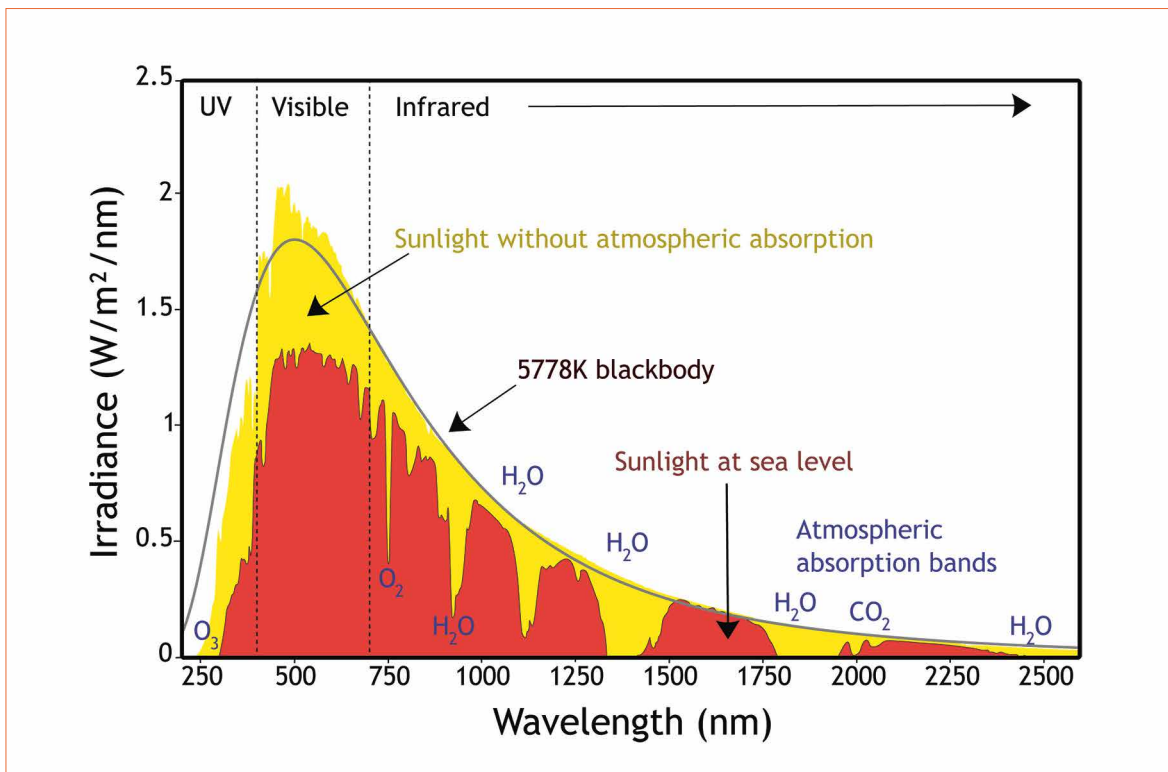
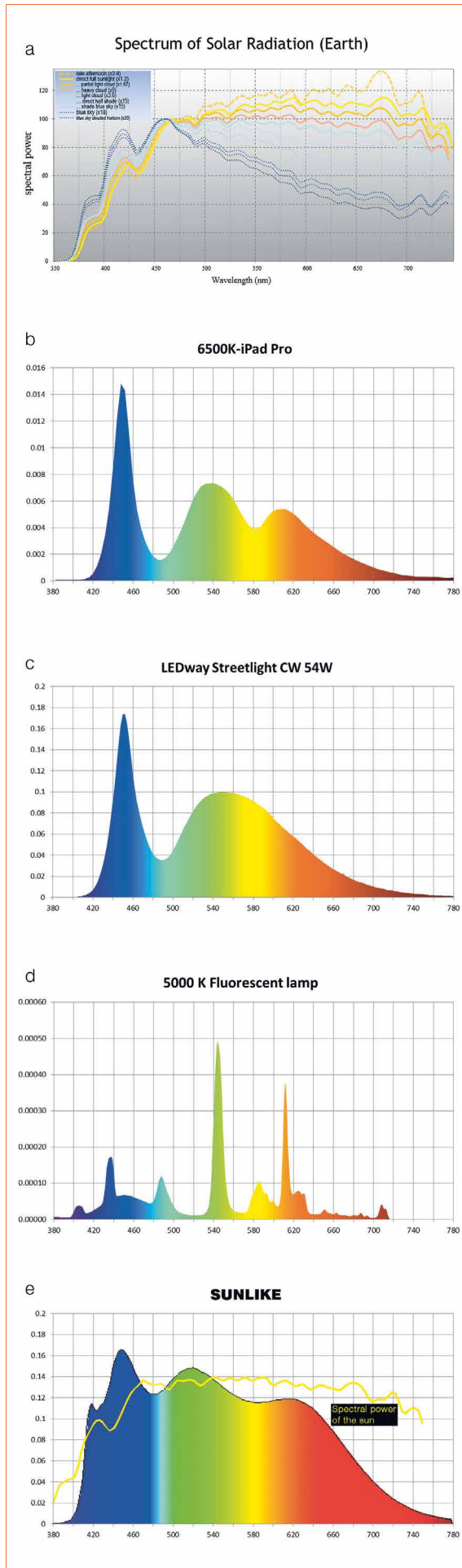

Figure 4: Solar radiation spectrum for direct light at both the top of the Earth's atmosphere (represented by yellow area) and at sea level (red area) [6]

Figures 5a-e:
Daylight spectrum under different times of the day (a) [8], Ipad spectrum @ 6500 K CCT (b), streetlight spectrum 6500 K CCT (c), fluorescent lamp spectrum 5000 K CCT (d), SunLike spectrum 6500 K CCT (e) directly compared to the daylight spectrum of the sun



increase the similarity to sunlight spectrum is already happening by matching the visible spectrum of the LED to the sunlight and a second step could be full sunlight spectrum from UV to far IR when the technology will be driven not only by lm/w and will motivate companies to develop new solutions.

One of the most important points of reaching the sun with artificial light is to achieve the daylight spectrum at 6500 K CCT that is being demonstrated that have positive effects on the health of humans. The latest publication of the WELL standard [7] recommends natural light at least from 9am to 1pm with a certain values of Equivalent Melanopic Lux (EML) in order to have a better synchronization for the human circadian rhythm.

Spectrum comparison of daylight and some artificial light sources

It can easily be recognized that the new technology can cover most of the spectrum of the sunlight, while the other technologies are not covering it. Therefore it may be considered as artificial source of natural sunlight for daylight purposes.

Conclusions

This new trend adds complexity and opportunities to lighting manufacturers and society in general and also brings new challenges to regulators on how the efficiency and quality of the light is being measured as standard. Many installations are being developed already with the main focus on HCL like schools, offices, hospitals, houses, and the other main market today is the high quality of the light that is being implemented in shops (food, cars, jewelry, etc.), museums and photography studios.

Many questions arise as we keep discovering the effects of the visible and non-visible light in humans and we are just seeing the tip of the iceberg and it looks that a new revolution is coming in high quality LED lighting. ■

References:

- [1] Seoul Semiconductor archives
- [2] Protecting the Melatonin Rhythm through Circadian Healthy Light Exposure -<https://www.ncbi.nlm.nih.gov/pmc/articles/PMC4284776/>
- [3] Guidelines from EU commission - <https://ec.europa.eu/energy/sites/ener/files/documents/Implementation%20Guide%20Lighting.pdf>
- [4] <https://www.linkedin.com/in/alexander-wunsch-abb6b676/>
- [5] <http://lichtbiologie.de/>
- [6] http://commons.wikimedia.org/wiki/File:Solar_spectrum_ita.svg
- [7] <https://standard.wellcertified.com/light/circadian-lighting-design>
- [8] <https://en.wikipedia.org/wiki/sunlight>

Lighting Fair The 22nd

The 22nd China (Guzhen) International Lighting Fair

Concurrently: Guzhen Lighting Manufacturing Expo 2018 (Autumn)

22-26 October 2018

**Guzhen, Zhongshan,
Guangdong Province, China**

Main Venue: Guzhen Convention and Exhibition Center

Sub-venue:





LED professional Review (LpR) - Annual Subscriptions

LpR Digital Magazine

- 6 issues
- pdf download
- high resolution pictures and graphs
- printable
- commercial use
- access to all previous issues
- Euro 78.80

LpR Printed Magazine

- 6 issues
- Euro 158.40

<http://www.led-professional.com/subscription>

Cover-page

Artwork: Thomas Klobassa,
©LED professional 2017

Main Image: Arno Grabher-Meyer,
LED professional



Samsung booth at Light & Building 2018 - a demonstration of dynamic lighting and the latest LED Display technology

Next LpR

SMART TRENDS & ENVIRONMENT Issue 70 - Nov/Dec 2018

RESEARCH

“Best Papers” at LpS 2018: The Winning Paper

This year the number of topics that were submitted for the LpS Scientific Award was very broad. Starting from “Visible Light Communication”, going on to “Studies on the Influence of HCL on Performance” to “LED Packaging Materials” and “Micro-Optical Freeform Optical Design”, to name just a few. The winner will be presented at the LpS Get Together & Award Ceremony on September 26th, 2018. Without revealing too much at this point: The winning paper will - once again - be an absolute highlight of this LpR issue. ■

TECHNOLOGIES

Bluetooth Mesh Protocol as Applied to Lighting

Little more than one year ago, Bluetooth SIG released the Bluetooth Mesh standardization. Meanwhile it has become widely adopted and is also one of the favorite systems for lighting controls. The proposed article starts with an explanation of the Bluetooth Mesh protocol as applied to lighting control and define its key elements. In a second portion of the article, questions that lighting control evaluators could be asking their vendor will be answered. ■

APPLICATIONS

Enriching Horticultural Lighting for Faster Growth and Better Crops

Horticulture lighting is not a new lighting application, but it gained momentum with the introduction and evolution of LED lighting. In the meantime it is one of the fastest growing markets in lighting. The article shows how LED-based horticultural lighting can deliver even bigger advantages for commercial growers by introducing additional wavelengths that increase photosynthetic response. ■

ENVIRONMENT

Hazard or Hope? - LEDs and Wildlife

The introduction and widespread uptake of LEDs as outdoor lighting has caused no small amount of concern amongst conservation biologists. The prevailing impression that LEDs are always blue-white is well founded as adoption of LEDs for streetlights were invariably high color temperatures and with the deterioration of phosphors the blue wavelengths penetrated even more. But LEDs do have characteristics that differentiate them from other light sources and may allow for the reduction of environmental effects of lighting on species and habitats: direction, duration, intensity, and spectrum. The article sheds light on all these aspects. ■

subject to change

Imprint

LED professional Review (LpR), ISSN 1993-890X

Publishing Company

Luger Research e.U.

Institute for Innovation & Technology
Moosmahdstrasse 30
A 6850 Dornbirn, Austria / Europe
phone +43 5572 39 44 89
fax +43 5572 20 60 70
info(at)lugerresearch.com
www.lugerresearch.com

Publisher

Siegfried Luger +43 699 11 33 55 70
s.luger(at)led-professional.com

Editor-in-Chief

Arno Grabher-Meyer +43 699 11 33 55 18
a.g-m(at)led-professional.com

Int. Account Manager

Theresa Koenig +43 699 11 33 55 20
theresa.koenig(at)led-professional.com

MarCom Manager

Bronwen Rolls +44 797 401 2962
bronwen.rolls(at)led-professional.com

Your Sales Contacts

Austria, France, Italy, Switzerland, Int.

Brigitte Lindner +43 699 11 33 55 19
brigitte.lindner(at)led-professional.com

China, Hong-Kong

Lolo Yeung +852 9732 2081
lolo(at)castintl.com

Germany

Armin Wezel +49 30 526 891 92
armin(at)eurokom-media.de

India

Priyanka Rai +91 124 478 7331
priyanka.ra(at)binarysemantics.com

Japan

Eiji Yoshikawa +81 3 6751 0090
scala(at)s3.dion.ne.jp

South Korea

Jung Won Suh +82 2 78 58 222
sinsegi-2(at)sinsegimedia.info

Taiwan

Leon Chen +886 2 256 81 786-10
leon(at)jkmedia.com.tw

UK, Ireland, Benelux, Scandinavia

Zena Coupé +44 1923 85 25 37
zena(at)expomedia.biz

US East

Karen C Smith-Kernc +1 717 397 7100
KarenKCS(at)aol.com

US West & Canada

Alan A. Kernc +1 717 397 7100
AlanKCS(at)aol.com

Copyrights - Luger Research e.U.

The editors make every reasonable effort to verify the information published, but Luger Research e.U. assumes no responsibility for the validity of any manufacturers, non profit organizations or individuals claims or statements.
Luger Research e.U. does not assume and hereby disclaims any liability to any person for any loss or damage caused by errors or omissions in the material contained herein, regardless of whether such errors result from negligence, accident or any other cause whatsoever. You may not copy, reproduce, republish, download, post, broadcast, transmit, make available to the public, or otherwise use LED professional Review (LpR) content without prior written consent from Luger Research e.U. - Institute for Innovation & Technology, Austria. ■



! GET YOUR FREE E-MAGAZINE
www.led-professional.com/free



The Global Information Hub for Lighting Technologies

LED professional is the comprehensive publication and platform, connecting experts in the design, testing and production of the latest lighting technologies information from around the world.

LED
professional

MORE THAN
31,500
READERS

www.led-professional.com

powered by Luger Research e.U.

HortiCoolture. LED it grow!



© e!Pal

#LEDITGROW

*WE speed up
the future*

electronica Hall B6 Booth 404

Horticulture LED Lighting

New horticultural products from the high power ceramic series. Specially chosen wavelengths (450 nm, 660 nm and 730 nm) increase photosynthesis, optimizing plant development and growth. With outstanding PPF-value, small size and low power consumption, the WL-SMDC is the future choice for horticultural lighting. Available ex stock. Samples free of charge.

For further information please visit:

www.we-online.com/leditagrow

For a short introduction of Horticulture

LEDs read our Application Note:

www.we-online.com/AN-Horti

- High efficacy
- Individually adjustable color spectrum for each plant
- Full color spectrum available incl. white, UV and IR-LEDs
- Low thermal resistance
- Electrically neutral thermal path
- One footprint for all colors

